

LM5068

Negative Voltage Hot Swap Controller

General Description

The LM5068 hot-swap controller provides intelligent control of power supply connections during the insertion and removal of circuit cards powered by live system backplanes.

The LM5068 provides both in-rush current control and short-circuit protection functions, and limits power supply transients in the backplane caused by the insertion of additional circuit cards. The LM5068 controls the external N-Channel MOSFET to provide programmable load current limiting and circuit breaker functions using a single external current sense resistor. The LM5068 issues a power good (PWRGD) signal at the conclusion of a successful power-on sequence. Input over-voltage or under-voltage fault conditions will cancel the PWRGD indication.

The LM5068-1 and -2 indicate power-good as an open-drain active high PWRGD state. The LM5068-3 and -4 indicate power-good as an open-drain active low PWRGD state. The LM5068-1 and -3 latch off after a fault condition is detected while the LM5068-2 and -4 continuously re-try at intervals set by a programmable timer.

The LM5068 is available in a MSOP-8 package.

Features

- Safe module insertion and removal from live backplanes
- In-rush current limiting for safe board insertion into live backplanes
- Fast response to over-current fault conditions with active current limiting
- -10V to -90V input range
- Programmable under-voltage/over-voltage shutdown protection with adjustable hysteresis
- Programmable multi-function timer for board insertion de-bounce delay
- Fault timer avoids nuisance trips caused by short duration load transients
- Active gate clamping during initial power application
- Available in both latched fault and automatic re-try versions
- Available with either active HIGH or active LOW power good flag

Applications

- - 48V Power Modules
- Central Office Switching
- Distributed Power Systems
- Electronic Circuit Breaker
- PBX Systems
- Negative Power Supply Control

Typical Application

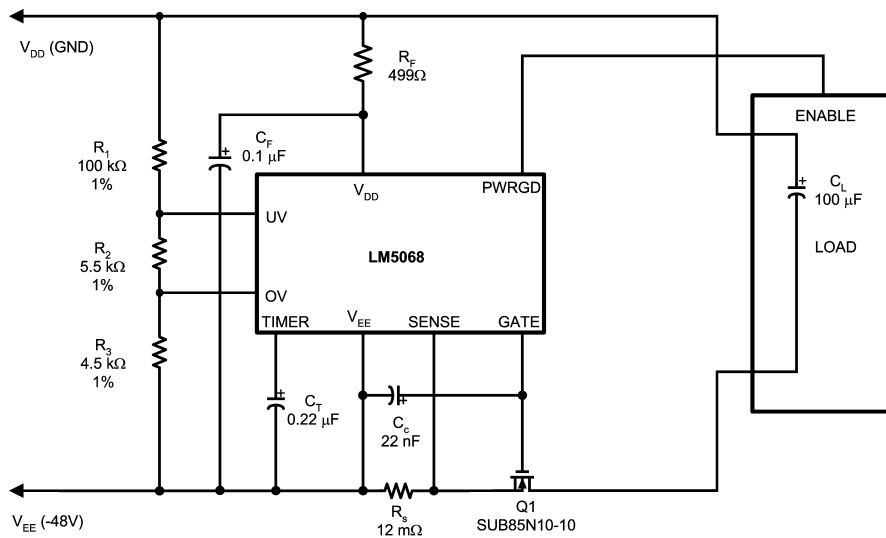

Negative Power Supply Control

20078601

Connection Diagram

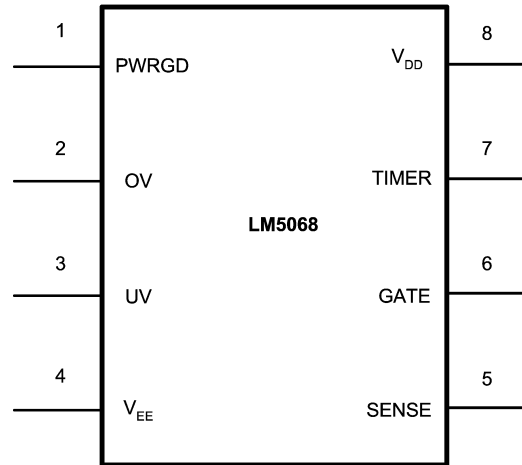

20078602

Pin Description

PIN	NAME	DESCRIPTION	APPLICATION INFORMATION
1	PWRGD	Open Drain Power Good indicator	Following a successful power-up sequence the PWRGD signal will be active. The LM5068-1 and -2 are configured for an active power-good state as HIGH, while the LM5068-3 and -4 are configured for an active power-good state as LOW.
2	OV	Line Over-Voltage Shutdown	An external resistor divider from the power source sets the over-voltage shutdown level. Hysteresis is generated by an internal current source which sources 20 μ A into the external divider when the OV pin exceeds 2.5V.
3	UV	Line Under-Voltage Shutdown	An external resistor divider from the power source sets the under-voltage shutdown level. Hysteresis is set by an internal current source which sinks 20 μ A from the external divider when the UV pin falls below 2.5V.
4	V_{EE}	Negative Supply Voltage Input	
5	SENSE	Current Sense Input	Load current is monitored via an external current sense resistor (R_s). If the voltage across R_s exceeds 50mV the fault timer is initiated. Load current is actively limited to 100mV/ R_s . If the sense voltage exceeds 200mV due to a catastrophic fault, the fast gate pull down circuit will reduce the MOSFET gate voltage and initiate active current limiting.
6	GATE	N-Channel MOSFET Gate Drive Output	This output is pulled high by a 60 μ A current source to turn on the MOSFET.
7	TIMER	Timer Input	An external capacitor connected to this pin sets the initial start-up delay and the delay to shutdown in the event of an over-current condition. This pin is also used for the automatic re-try timing sequence, following fault shutdown (-2 and -4 versions).
8	V_{DD}	Positive Supply Voltage Input	

Configuration Table

Part Number	Latch Off /Successive Re-try	Power Good Polarity	Package
LM5068MM-1/MMX-1	Latch Off	Active HIGH	MSOP- 8
LM5068MM-2/MMX-2	Auto Re-try	Active HIGH	
LM5068MM-3/MMX-3	Latch Off	Active LOW	
LM5068MM-4/MMX-4	Auto Re-try	Active LOW	

Ordering Information

Order Number	Package Marking	NSC Package Drawing	Supplied As
LM5068MM-1	S66B	MUA08A	Available Soon
LM5068MMX-1	S66B		Available Soon
LM5068MM-2	S67B		1000 Units on Tape and Reel
LM5068MMX-2	S67B		3500 Units on Tape and Reel
LM5068MM-3	S68B		Available Soon
LM5068MMX-3	S68B		Available Soon
LM5068MM-4	S69B		Available Soon
LM5068MMX-4	S69B		Available Soon

Absolute Maximum Ratings (Note 1)

If Military/Aerospace specified devices are required, please contact the National Semiconductor Sales Office/Distributors for availability and specifications.

V_{DD} (V_{DD} to V_{EE})	100V
PWRGD (PWRGD to V_{EE})	100V
SENSE (SENSE to V_{EE})	8V
UV/OV (Clamped) (UV/OV to V_{EE})	8V
All Other Inputs to V_{EE}	16V

Junction Temperature (T_J)	+150°C
Storage Temperature (T_S)	-55°C to +150°C
Soldering Information	
ESD Rating (Note 2)	2kV

Operating Ratings

Supply Voltage Range (V_{DD})	10V to 90V
Junction Temp. Range	-40°C to +105°C

Electrical Characteristics

Specifications in standard typeface are for $T_J = +25^\circ\text{C}$, and those in **boldface type** apply over the full operating junction temperature range. Unless otherwise noted $V_{DD} - V_{EE} = 48\text{V}$.

Symbol	Parameter	Conditions	Min	Typ	Max	Units
V_{DD} Supply						
I_{IN}	Supply Current			0.82	1.3	mA
I_{SD}	Shutdown Current	UV/OV = 0V		580	1000	μA
$V_{DD} - V_{EE}$	Operating Supply Range		10		90	V
UV/OV Shutdown						
V_{UVS}	V_{DD} Under-voltage Shutdown			8.5		V
V_{UVSH}	V_{DD} Under-voltage Shutdown Hysteresis			0.6		V
V_{UV}	Under-voltage Comparator Threshold		2.45	2.5	2.55	V
I_{UVHCS}	Under-voltage Hysteresis Current Source		18	20	22	μA
V_{OV}	Over-voltage Comparator Threshold		2.45	2.5	2.55	V
I_{OVHCS}	Over-voltage Hysteresis Current Sink		18	20	22	μA
t_{UVCD}	UV Comparator Delay	UV Low to Gate Low		1100		ns
t_{OVCD}	OV Comparator Delay	OV High to Gate Low		500		ns
Current Limit Voltage						
V_{CB}	Circuit Breaker Current Limit Voltage		40	50	60	mV
V_{AC}	Analog Current Limit Voltage		80	100	120	mV
V_{FDC}	Fast Discharge Current Limit Voltage (Fast Gate Pull Down Threshold)		150	200	250	mV
Sense Input						
I_{SENSE}	Sense Input Current	$V_{SENSE} = 50\text{mV}$	-30	-15		μA
Timer						
V_{THVT}	Timer High Voltage Threshold			4		V
V_{TLVT}	Timer Low Voltage Threshold			1		V
I_{TIMER}	Timer On (Initial Cycle, Sourcing)	$V_{TIMER} = 2\text{V}$	4	6	8	μA
	Timer Off (Initial Cycle, Sinking)	$V_{TIMER} = 2\text{V}$		27		mA
	Timer On (Circuit Breaker, Sourcing)	$V_{TIMER} = 2\text{V}$	200	240	280	μA
	Timer Off (Cooling Cycle, Sinking)	$V_{TIMER} = 2\text{V}$	4	6	8	μA

Electrical Characteristics (Continued)

Specifications in standard typeface are for $T_J = +25^\circ\text{C}$, and those in **boldface type** apply over the full operating junction temperature range. Unless otherwise noted $V_{DD} - V_{EE} = 48\text{V}$.

Symbol	Parameter	Conditions	Min	Typ	Max	Units
Gate Drive						
V_G	Saturation Gate Drive Voltage	$V_{DD} - V_{EE} = 48\text{V}$	9	10.6	12	V
		$V_{DD} - V_{EE} = 10\text{V}$		7.8		V
V_{GLT}	Gate Low Threshold	Before Gate ramp-up		0.5		V
I_{GATE}	Gate Pin Current (Sourcing)	$V_{SENSE} = 0\text{V}$	40	60	80	μA
	Gate Pin Current (Sinking)	$V_{SENSE} = 150\text{mV}$ $V_{GATE} = 3\text{V}$		2.7		mA
	Gate Pin Current (Sinking)	$V_{SENSE} = 300\text{mV}$ $V_{GATE} = 1\text{V}$		300		mA
PWRGD						
V_{PGLV}	PWRGD Low Voltage	$I_{SINK} = 1\text{mA}$		0.2	0.6	V
I_{PGLC}	PWRGD High Leakage Current	$V_{PWRGD} = 90\text{V}$		1		μA
V_{PGV}	GATE Voltage at onset of PWRGD			8		V

Note 1: Absolute Maximum Ratings are limits beyond which damage to the device may occur. Operating Ratings are conditions under which operation of the device is intended to be functional. For guaranteed specifications and test conditions, see the Electrical Characteristics.

Note 2: The ESD rating of Pin 7 is 1.5kV. It is recommended that proper ESD precautions are taken to avoid performance degradation or loss of functionality.

Block Diagram

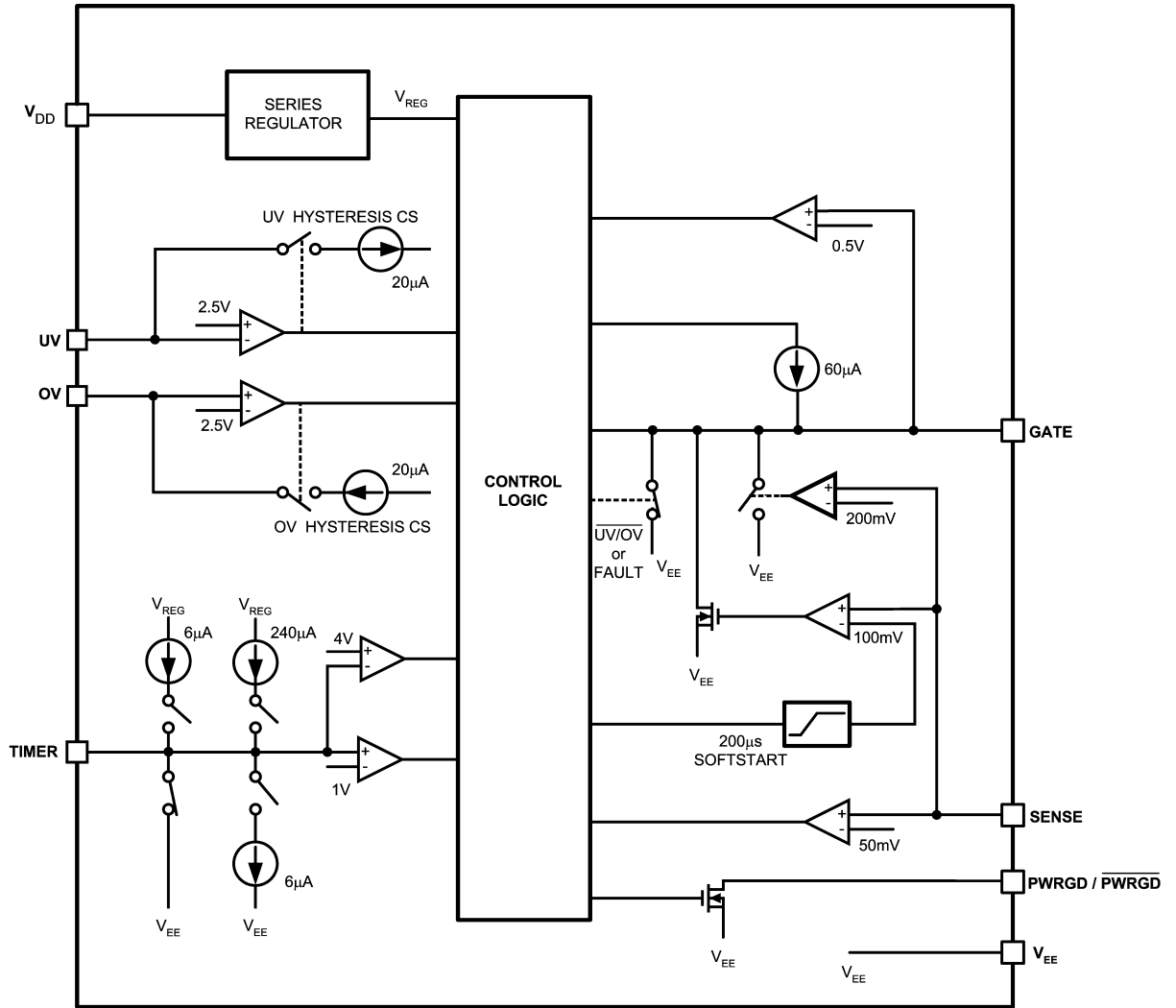

20078603

Typical Performance Characteristics

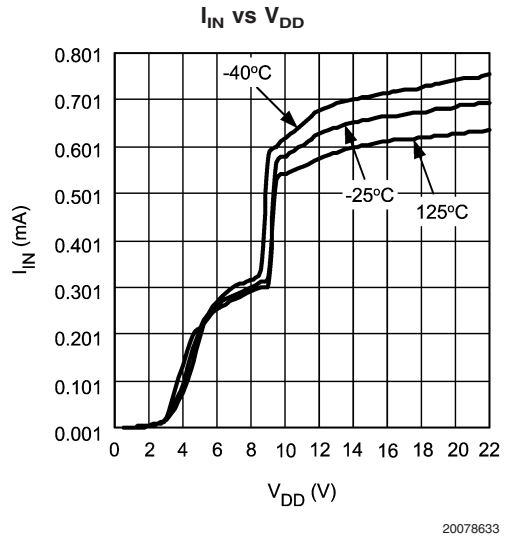
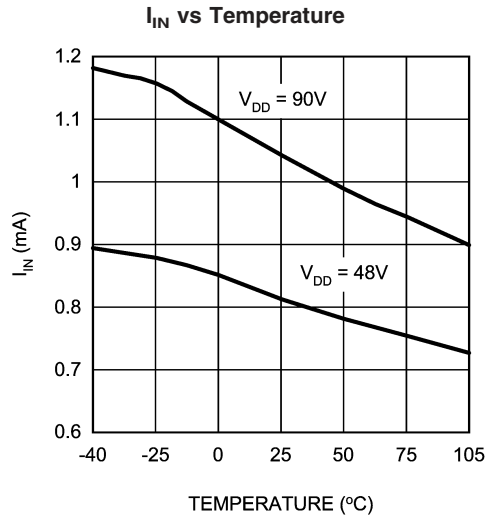

V_{DD} Under-Voltage Shutdown (V_{UVS}) vs Temperature

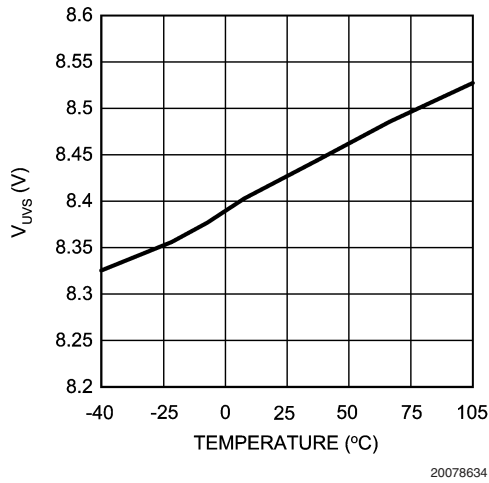

V_{DD} Under-Voltage Shutdown Hysteresis (V_{UVSH}) vs Temperature

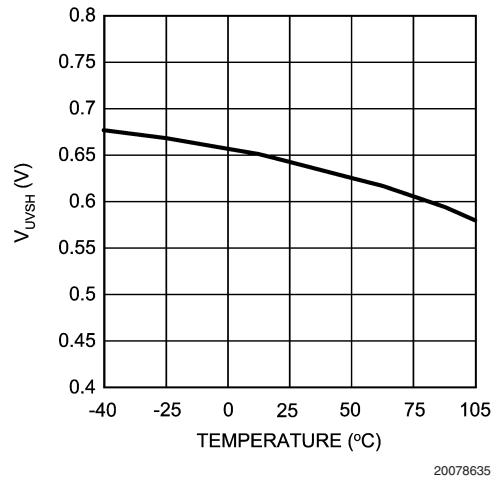

Under-Voltage Comparator Threshold (V_{UV}) and Over-Voltage Comparator Threshold (V_{OV}) vs Temperature

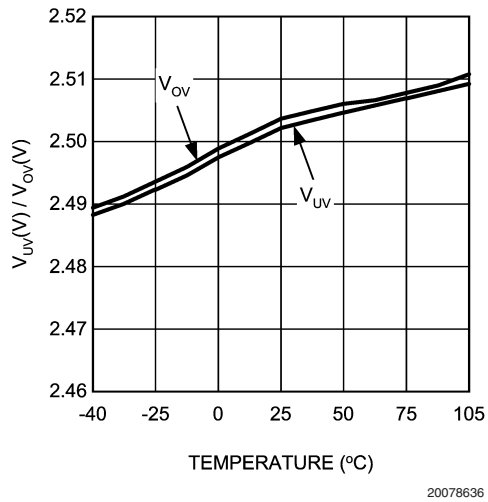

Under-Voltage Comparator Threshold Hysteresis Current Source (I_{UVHCS}) vs Temperature

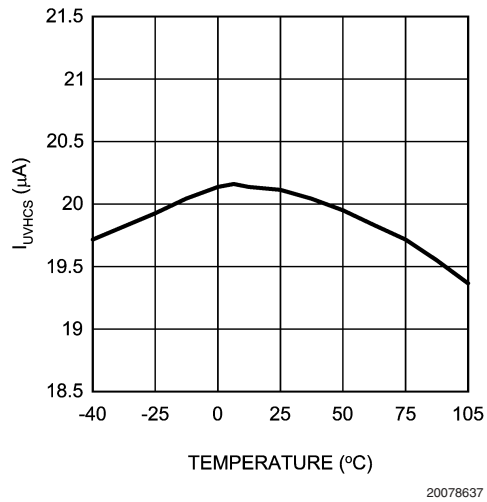

Typical Performance Characteristics (Continued)

Over-Voltage Comparator Threshold Hysteresis Current Sink (I_{OVHCS}) vs Temperature

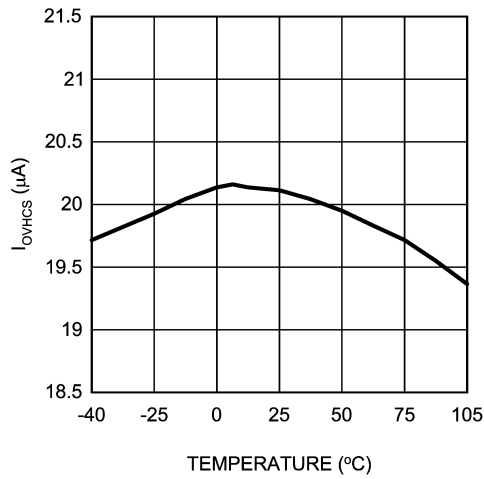

20078638

UV Comparator Delay (t_{UVCD}) and OV Comparator Delay (t_{OVCD}) vs Temperature

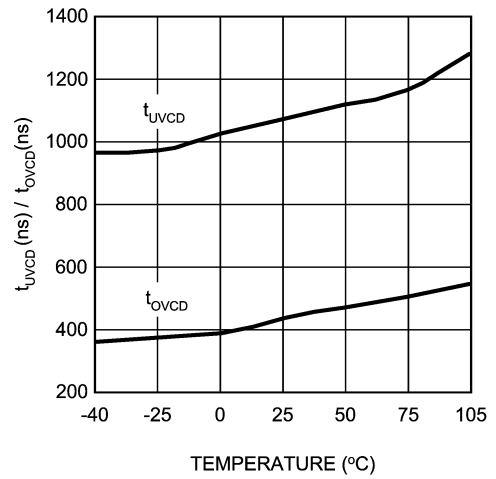

20078639

Circuit Breaker Current Limit Voltage (V_{CB}) vs Temperature

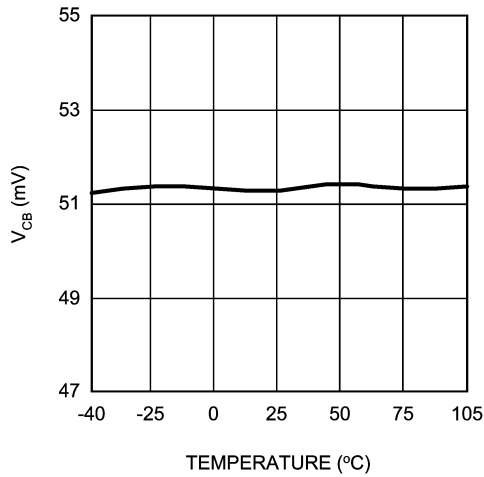

20078640

Analog Current Limit Voltage (V_{AC}) vs Temperature

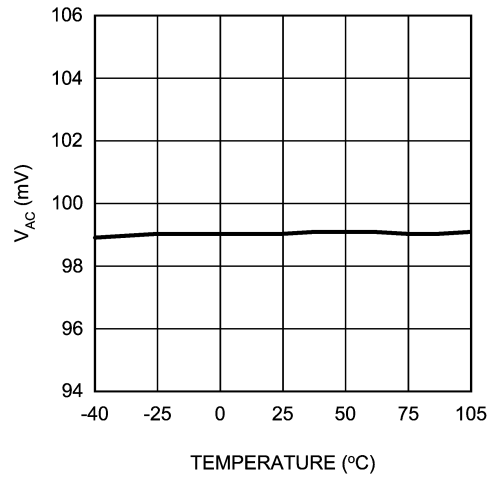

20078641

Fast Discharge Current Limit Voltage (V_{FDC}) vs Temperature

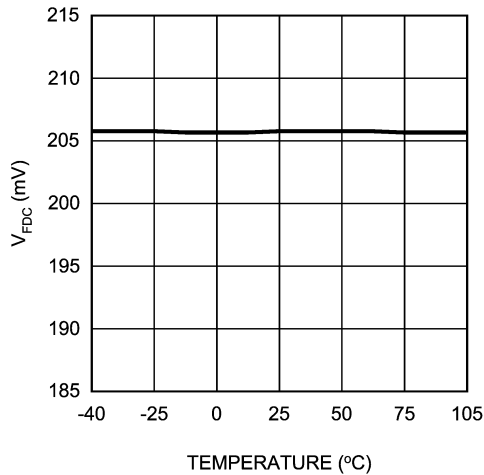

20078642

Timer High Voltage Threshold (V_{THVT}) vs Temperature

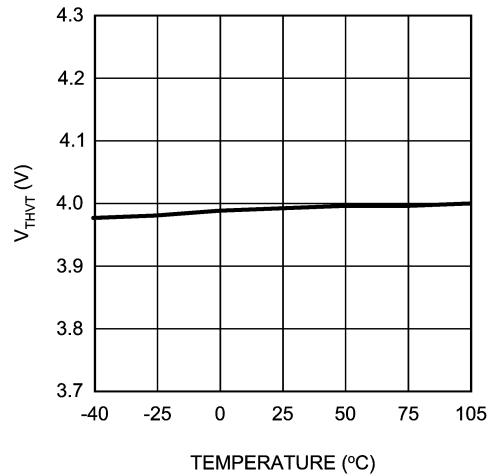

20078643

Typical Performance Characteristics (Continued)

Timer Low Voltage Threshold (V_{TLVT}) vs Temperature

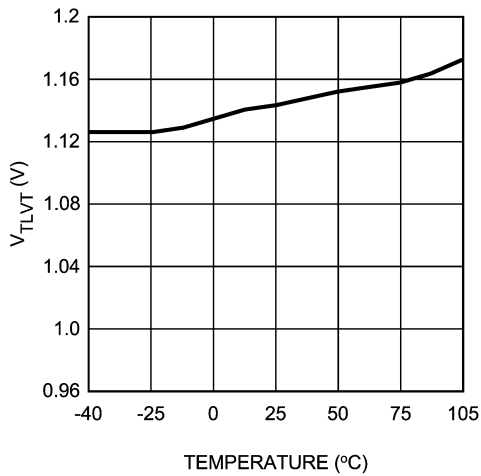

20078644

Timer On (Initial Cycle, Sourcing) vs Temperature

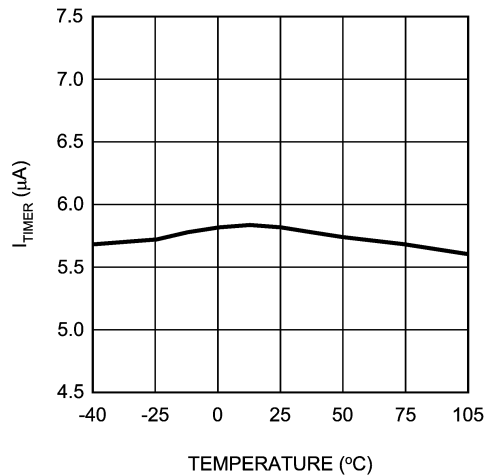

20078645

Timer On (Circuit Breaker, Sourcing) vs Temperature

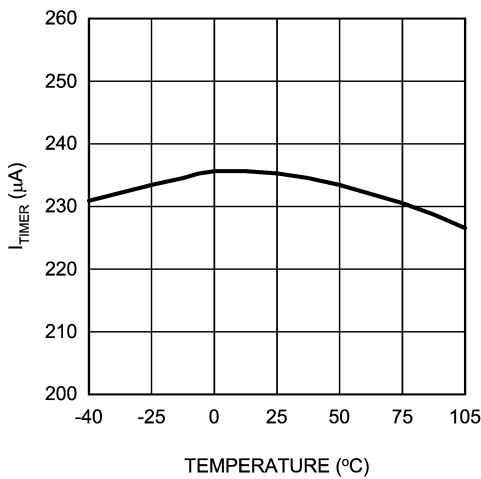

20078647

Timer Off (Cooling Cycle, Sinking) vs Temperature

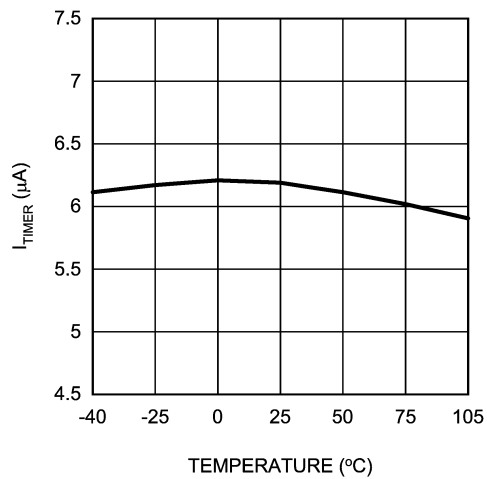

20078648

Saturation Gate Drive Voltage (V_G) vs Temperature (48V)

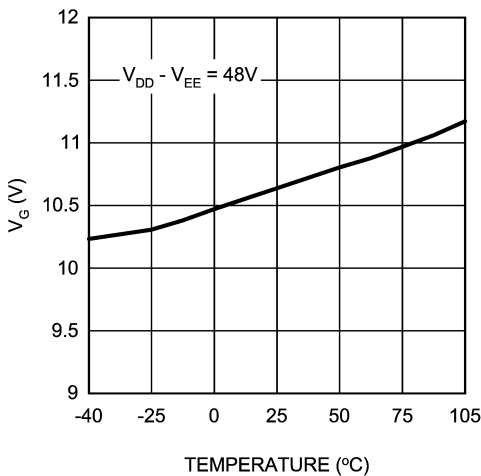

20078649

Saturation Gate Drive Voltage (V_G) vs Temperature

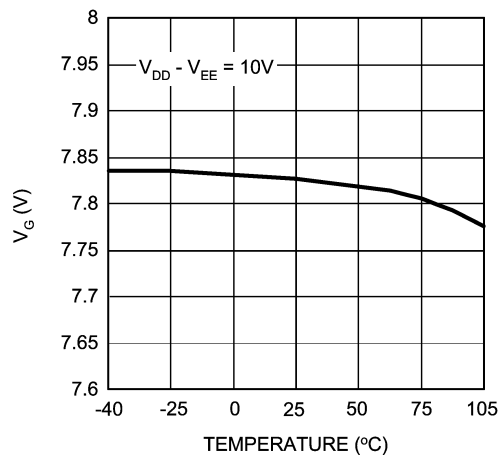

20078650

Typical Performance Characteristics (Continued)

Gate Pin Current (Sourcing) (I_{GATE}) vs Temperature

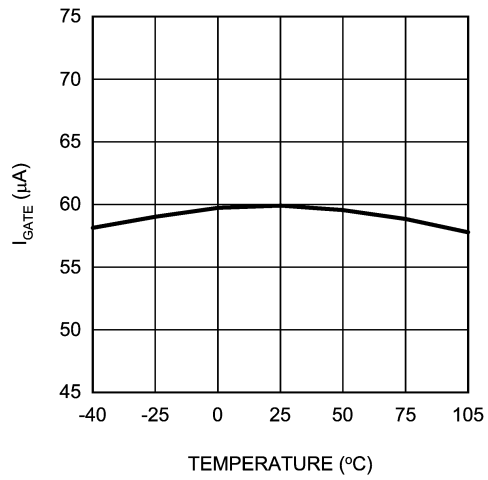

20078652

PWRGD Low Voltage (V_{PGLV}) vs Temperature

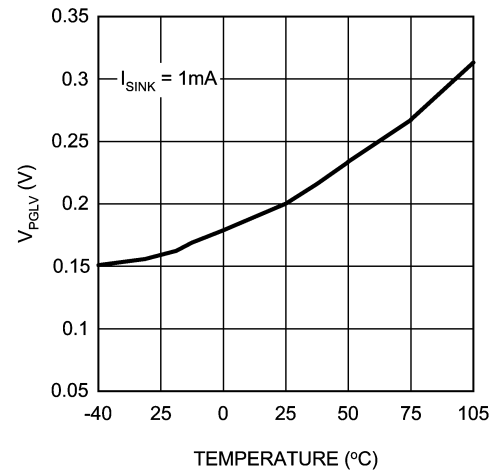

20078655

Gate Voltage at onset of PWRGD (V_{PGV}) vs Temperature

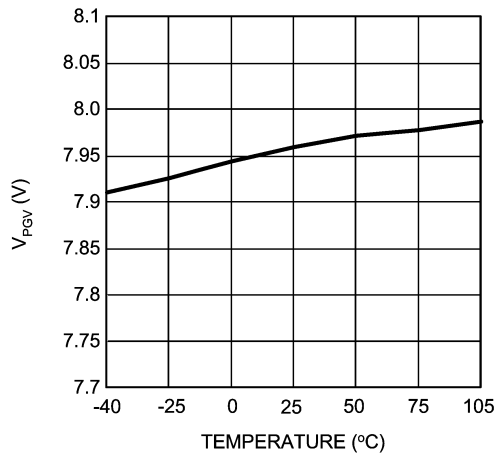

20078656

Function Description

The LM5068 is designed to facilitate the insertion and removal of circuit cards into live backplanes in a controlled manner. Because the supply bypass capacitors on the circuit card can draw large transient currents, it is critical to control the supply current during insertion to limit system power glitches and connector damage. Controlling in-rush current prevents other boards in the system from resetting during board insertion. Load short-circuit protection is accomplished by active current limiting of the load current. The topology of the LM5068 is illustrated in the simplified application circuit shown in Figure 1.

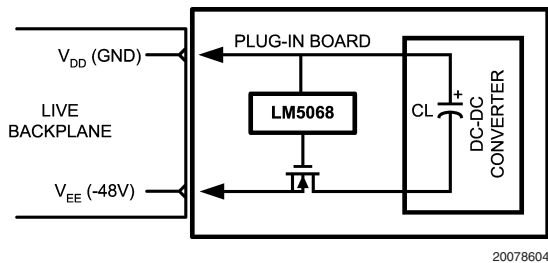

FIGURE 1. LM5068 Topology

Start-Up Operation

The LM5068 resides on a removable circuit card. Power is applied to the load or power conversion circuitry through an external N-Channel MOSFET switch and current sense resistor.

When power is initially applied to the card, the gate of the external MOSFET is held low. When certain interlock conditions are met, a turn-on sequence begins and an internal 60 μA current source charges the gate of the MOSFET. To initiate the start-up sequence, all of the following interlock conditions must be satisfied:

- The input voltage $V_{DD} - V_{EE}$ exceeds $9V(V_{UVS})$
- The voltage at UV is above 2.5V (V_{UV})
- The voltage at OV falls below 2.5V (V_{OV})
- The voltage on the Timer capacitor (C_T) is less than 1V (V_{TLVT})
- The GATE pin is below 0.5V (V_{GLT})

When all of the interlock conditions are met, a 6 μA TIMER current source is enabled to charge the timer capacitor C_T . During this initial timer sequence the GATE output is held low. When the C_T capacitor successfully charges up to 4V, the TIMER circuit resets the timer capacitor to 1V and activates a 60 μA current source (I_{GATE}) into the MOSFET gate.

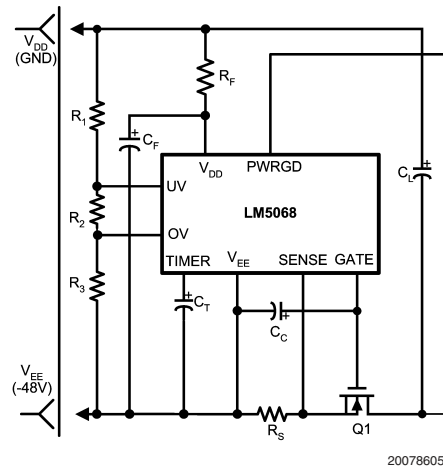

FIGURE 2. Hot Swap Controller

Over and Under-Voltage Lockout

The line Under-voltage lockout (UVLO) circuitry of the LM5068 monitors V_{DD} for under-voltage conditions, where V_{UVS} is the negative going threshold and the hysteresis is V_{UVSH} (see Electrical Characteristics). A $V_{DD} - V_{EE}$ voltage less than 8.5V (V_{UVS}) keeps the controller in a disabled mode. Raising the V_{DD} voltage above 9.1V ($V_{UVS} + V_{UVSH}$) releases the V_{DD} UVLO and enables the controller.

In addition to the internal UVLO circuit, the UV and OV comparators monitor the input line voltage through an external resistor divider. Programmable UV and OV comparator hysteresis is implemented with switched 20 μA current sources that raise or lower the OV and UV pins when the comparators reach their threshold. Either UV or OV fault conditions will switch the GATE pin low and disconnect the power to the load. To restart the GATE pin, the supply voltage must return to a level which is greater than the UV fault and less than the OV fault threshold and all of the interlock conditions (with the exception of the TIMER) must be met.

Removal of the circuit card from the backplane initiates an under-voltage condition. The series MOSFET is then disabled to disconnect the source of power to the load. The under-voltage threshold and hysteresis are programmed by the external resistor divider connected to the UV pin.

Timer

The value of the C_T capacitor sets the duration of the LM5068's timer delay and filter functions. There are four charging and discharging modes:

1. 6 μA slow charge for initial timing delay and post-fault re-try timer (LM5068-2 and -4)
2. 240 μA fast charge for circuit breaker delay.
3. 6 μA slow discharge for circuit breaker "cool-off".
4. Low impedance switch to reset capacitor after initial timing delay, input under-voltage lockout, and during over-voltage and under-voltage initial timing.

Current Control

The LM5068 has three current sense thresholds which protect the backplane supply and circuit card from overload

Current Control (Continued)

conditions. The voltage drop across the sense resistor (R_S) is monitored at the SENSE pin. The over-current protection functions are determined through the following three distinct thresholds at the SENSE pin:

1. Circuit Breaker (CB) threshold (typically 50mV)
2. Analog Current Limit (ACL) loop threshold (typically 100mV)
3. Fast Discharge Current (FDC) threshold (typically 200mV)

When the voltage drop across R_S exceeds 50mV the Circuit Breaker comparator indicates an over-load condition. The TIMER sources 240 μ A into C_T when SENSE exceeds 50mV and sinks 6 μ A from C_T when SENSE falls below 50mV. If the C_T capacitor ramps to a 4V threshold, a fault condition is declared and the gate of the MOSFET is forced low, disconnecting the power to the load.

Active Current Limiting (ACL) is activated when the voltage across sense resistor R_S reaches 100mV. The LM5068 controls the gate of the MOSFET and maintains a constant output load current equal to $100\text{mV}/R_S$. In the ACL mode the SENSE pin is greater than 50mV and the TIMER charges C_T with 240 μ A. A fault will be declared if the LM5068 remains in the ACL mode longer than the circuit breaker timer period.

Fast Discharge Current (FDC) responds to fast rising overloads such as short circuit faults. During a short circuit event the fast rising current may overshoot past the ACL threshold due to the finite response time of the ACL loop. If the SENSE voltage reaches 200mV a fast discharge comparator quickly pulls GATE pin low. The rapid response of the FDC circuit assures a fast and safe transition to the ACL mode.

The LM5068 circuit breaker action filters low duty cycle over-load conditions to avoid declaring a fault during short duration load transients. The timer charges capacitor C_T with 240 μ A when the SENSE voltage is greater than 50mV. When the SENSE pin voltage falls below 50mV, a 6 μ A current discharges the TIMER capacitor. Repetitive over-current faults with duty cycle greater than 2.5% will eventually charge C_T and trip the fault timer. This feature protects the pass MOSFET which has a fast heating and slow cooling characteristic.

Latch-Off and Auto-Retry

If the fault conditions persist long enough for TIMER to charge C_T to 4V, the LM5068 latches off (LM5068-1, -3) or switches off and initiates the re-try timer (LM5068-2, -4).

At the fault condition, after reaching the 4V, the TIMER pin will continue to ramp-up with 6 μ A current source until it reaches the internal regulated voltage, which is equivalent to the saturation GATE drive voltage. The LM5068-1 and LM5068-3 remains off until the controller is reset by either temporarily pulling the UV pin low, pulling the TIMER pin below 1 volt, or decreasing the input voltage below the internal V_{DD} under-voltage lockout (UVLO) threshold.

The LM5068-2 and LM5068-4 respond to a fault condition by pulling the GATE and TIMER pins low and then initiating a timer sequence for automatic re-try. The re-try timer sequence begins with C_T capacitor being charged slowly to 4V with a 6 μ A current source and then discharged quickly to 1V with a 30mA discharge current. After 8 charge/discharge cycles the GATE pin is released and charged with a 60 μ A

current source. If the fault condition persists, the LM5068 will again turn off the MOSFET and another 8-cycle fault timer sequence will begin.

Power Good Flag

The power good flag (PWRGD) is activated when the MOSFET GATE is fully enhanced ($>8\text{V}$) and the voltage input UV and OV comparators are satisfied. The power good output is a 90V capable open drain N-Channel MOSFET. The LM5068-1 and LM5068-2 provide an active high power-good state, while the LM5068-3 and LM5068-4 are configured for an active low power-good state. The UV comparator, OV comparator, V_{DD} UVLO, or a circuit breaker time-out will reset the power good flag.

Internal Soft-Start

An internal soft-start feature ramps the (positive) input of the analog current limit amplifier during initial start-up. The ramp duration is approximately 200 μ s. This feature reduces the load current slew rate (di/dt) at start-up.

Design Information

The LM5068 contains an internal regulator enabling the V_{DD} pin to be connected directly to the line voltage from 10 to 90V. A local RC filter (0.1 μ F ceramic capacitor and 499 Ω resistor) connected between V_{DD} and V_{EE} is recommended to filter supply transients that exceed the 100V Absolute Maximum Rating.

UV and OV Thresholds and Voltage Divider Selection for R1, R2, and R3

Two comparators detect under-voltage and over-voltage conditions at the UV and OV pins. The threshold voltages (V_{UV} , V_{OV}) of the UV and OV comparators are nominally 2.5V. Hysteresis is accomplished by 20 μ A current sources (I_{UVHCS}), into the external resistor divider connected to the UV and OV pins as shown in *Figure 3*

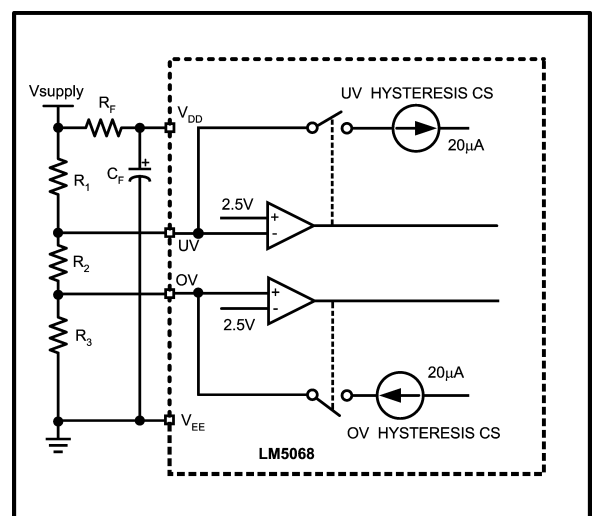

20078606

FIGURE 3. UV/OV Setting

UV and OV Thresholds and Voltage Divider Selection for R1, R2, and R3 (Continued)

Hysteresis is necessary to prevent a possible “chattering” condition when the controller enables or disables the external MOSFET. The change in line current interacts with the line impedance. This interaction can cause several rapid on/off cycles on the MOSFET. A hysteresis window larger than the line impedance voltage drop prevents this condition.

The impedance seen looking into the resistor divider from the UV and OV pin determines the hysteresis level. UV/OV ON and OFF thresholds are calculated as follow:

$$\text{UV turn-on} = \left(\frac{R_1}{R_2 + R_3} V_{UV} \right) + V_{UV} + I_{UVHCS} R_1$$

$$\text{UV turn-off} = \frac{R_1 + R_2 + R_3}{R_2 + R_3} V_{UV}$$

$$\text{OV turn-off} = \frac{R_1 + R_2 + R_3}{R_3} V_{OV}$$

$$\text{OV turn-on} = \left[\left(\frac{V_{OV}}{R_3} - I_{UVHCS} \right) (R_1 + R_2) \right] + V_{OV}$$

The independent UV and OV pins provide complete flexibility for the user to select the operational voltage range of the system. However, due to the UV Abs Max rating, the UV and OV thresholds can't be simultaneously set to extremes in one resistor string. For the wide ranges of input voltages (i.e. UV threshold to 12V and OV threshold to 90V) it is recommended to use two separate voltage dividers to set the UV and OV thresholds independently.

The typical operating ranges of under-voltage and over-voltage thresholds are calculated from the above equations with known resistors. For example, for resistor values: R1=130KΩ, R2=5.5KΩ, and R3=4.5KΩ, the computed thresholds are:

- UV turn-on = **37.60V**
- UV turn-off = **35.0V**
- OV turn-off = **77.78V**
- OV turn-on = **75.07V**

To maintain the threshold's accuracy, a resistor tolerance of 1% or better is recommended.

Calculation of Normal, Circuit Breaker, and Retry Timing

The C_T capacitor at the TIMER pin controls the timing functions of the LM5068. When the interlock conditions are met the timer capacitor is charged to 4V in a slow initial delay time period t_{IDT} calculated from:

$$t_{IDT} = \frac{4V \times C_T}{6 \mu A} \quad (1)$$

If the SENSE pin detects more than 50mV across R_S, the TIMER pin charges C_T with 240μA. The Circuit Breaker timeout period t_{CBT} is calculated from:

$$t_{CBT} = \frac{4V \times C_T}{240 \mu A} \quad (2)$$

When the LM5068-2 or LM5068-4 is latched, it pulls down the GATE pin and initiates eight, 6μA charging cycles between 1V and 4V on C_T. The total re-try time period t_{RT} is given by:

$$t_{RT} = \frac{8 \times 3V \times C_T}{6 \mu A} \quad (3)$$

Sense Resistor (R_S), Timer Capacitor (C_T) and N-Channel Mosfet (Q1) Selection

To select the proper MOSFET, the following safe operating area (SOA) parameters are needed: maximum input voltage, maximum current and the maximum current conduction time.

First, R_S is calculated for the maximum operating load current (I_{L(MAX)}) and the minimum circuit breaker trip point (V_{CB(MIN)}):

$$R_S = \frac{V_{CB(MIN)}}{I_{L(MAX)}} = \frac{40mV}{I_{L(MAX)}} \quad (4)$$

During the initial charging process, the LM5068 may operate the MOSFET in current limit, forcing V_{AC(MIN)} (80mV) to V_{AC(MAX)} (120mV) across R_S.

The minimum in-rush current and maximum short-circuit limit are calculated from:

$$I_{INRUSH(MIN)} = \frac{80mV}{R_S} \quad (5)$$

$$I_{SHORT-CIRCUIT(MAX)} = \frac{120mV}{R_S} \quad (6)$$

The value of TIMER capacitor (C_T) is calculated in order to prevent C_T from timing out before the load capacitor is fully charged using the slowest expected charging rate of the load capacitor. Assuming there is no initial resistive loading, the time necessary to charge the load capacitor C_L is calculated from:

$$t_{CL\ CHARGE} = \frac{C_L \times V_{IN(MAX)}}{I_{INRUSH(MIN)}} \quad (7)$$

Sense Resistor (R_S), Timer Capacitor (C_T) and N-Channel Mosfet (Q1) Selection (Continued)

Applying Equation (5) and Equation (7) to Equation (2) gives the TIMER capacitor value of:

$$C_T = \frac{C_L \times V_{IN(MAX)} \times R_S \times 240\mu A}{4V \times 80mV} \quad (8)$$

Finally, the SOA curves of a prospective MOSFET are checked using $V_{IN(MAX)}$, and $I_{SHORT-CIRCUIT(MAX)}$ calculated from equation Equation (6) and time of the current flow from Equation (2).

Example: For: $I_L=1A$, $V_{DD} = 48V$, $V_{DD(MAX)} = 100V$ and $C_L=100\mu F$,

$$R_S = \frac{40mV}{1A} = 40m\Omega$$

$$C_T = \frac{100\mu F \times 100V \times 40m\Omega \times 240\mu A}{4V \times 80mV} = 300nF$$

To account for tolerances of R_S , C_L , TIMER current and TIMER threshold voltage, the computed C_T value should be increased, for this example 50% was selected, therefore:

$$C_T = 300nF \cdot 1.5 = 450nF$$

The maximum active current limiting value and duration are:

$$I_{SHORT-CIRCUIT(MAX)} = \frac{120mV}{40m\Omega} = 3A \quad (9)$$

$$t_{CBT} = \frac{4V \times C_T}{240\mu A} = \frac{4V \times 450nF}{240\mu A} = 7.5ms \quad (10)$$

The N-channel MOSFET selection for use with the LM5068 controller in this example must be capable of sustaining

$V_{DD}=100V$ and $I_{(MAX)}=3A$ for 7.5ms in the worst case fault condition. A device that meets the established criteria is the Vishay - 5UB85N10-10.

External Sense Resistor

Precise current measurement depends on the accuracy of the sense resistor (R_S). For the optimal results, Kelvin connection and close location of R_S to the LM5068 should be considered. Figure 4 demonstrates PCB layout for the Kelvin sensing.

The R_S power rating should be greater than $I_L^2 \cdot R$, where I_L is the normal maximum operating load.

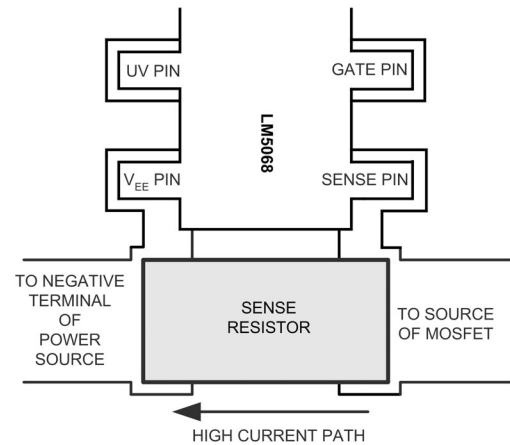

20078623

FIGURE 4. Sense Resistor Connections

Timing Diagrams

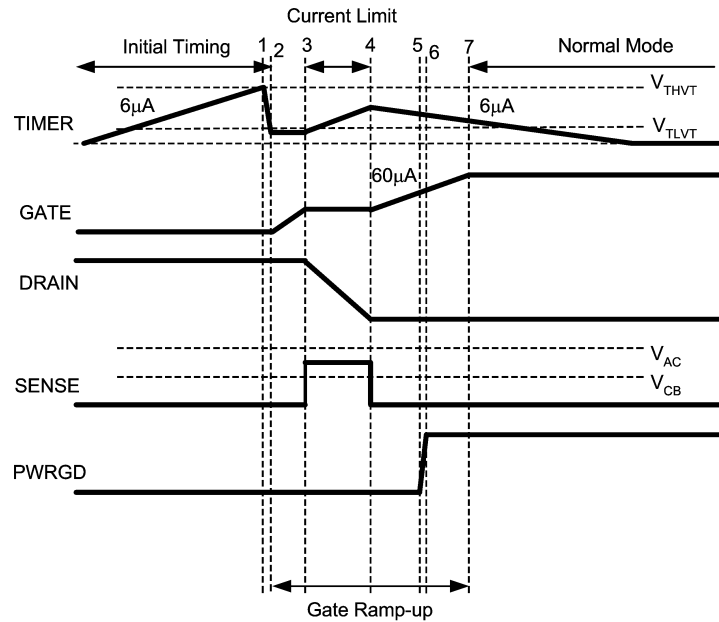

20078625

FIGURE 5. System Power-Up Timing Behavior

Assuming all of the initial conditions are met, the power-up sequence starts with Timer capacitor (C_T) getting charged. C_T is charged with $6\mu\text{A}$ current source up to V_{THVT} (4V) then quickly discharge to V_{TLVT} (1V). At time point (2) the $60\mu\text{A}$ GATE current source is enabled. The GATE voltage increases until the MOSFET starts conducting causing the SENSE voltage to increase until Active Current Limiting is

activated (3). During the current limiting period (3-4), C_T is charged again, but there is not enough time to reach the 4V threshold before the load capacitor is fully charged and the SENSE voltage falls below V_{CB} . The GATE continues to fully enhance the MOSFET and activating the PWRGD when the GATE voltage exceeds 8V.

Timing Diagrams (Continued)

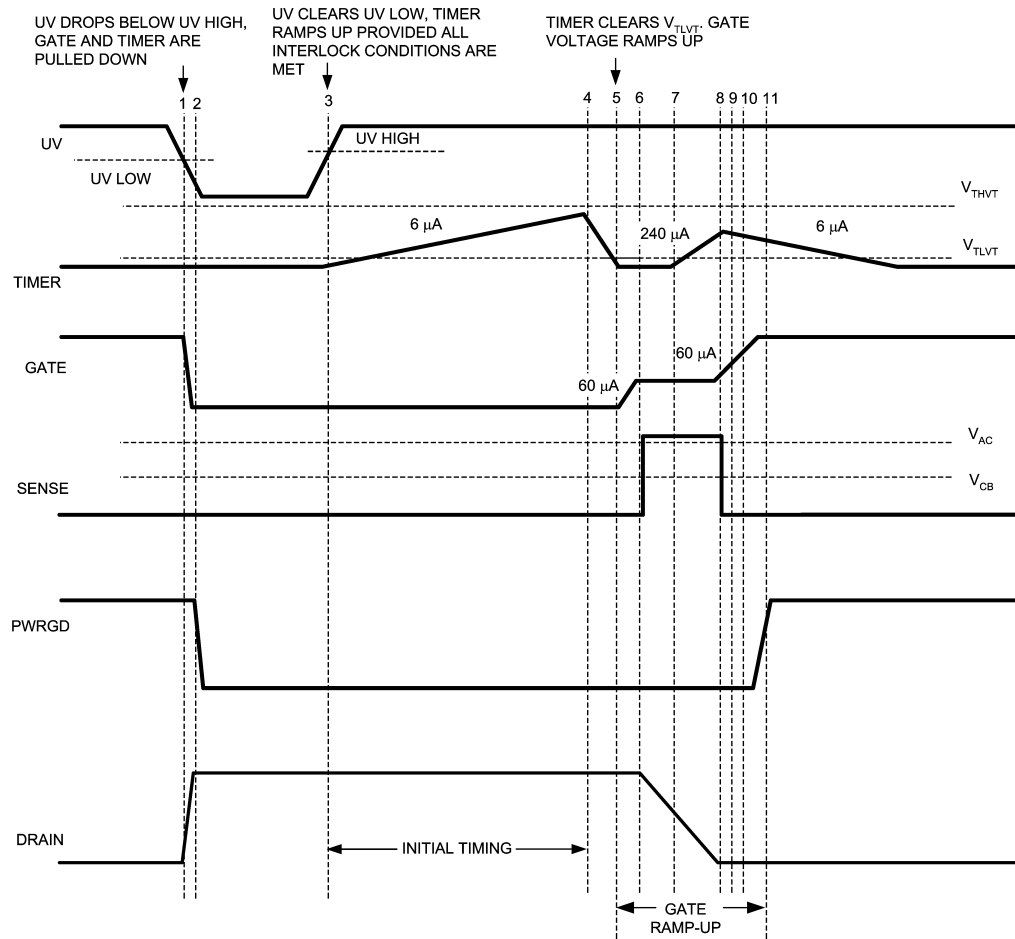

20078626

FIGURE 6. Under-Voltage Timing Behavior

UV drops below UV HIGH (time point 1) puts the controller into a disabled mode. Later, UV increases over the UV LOW threshold (time point 3), which initiates a system power-up sequence.

Timing Diagrams (Continued)

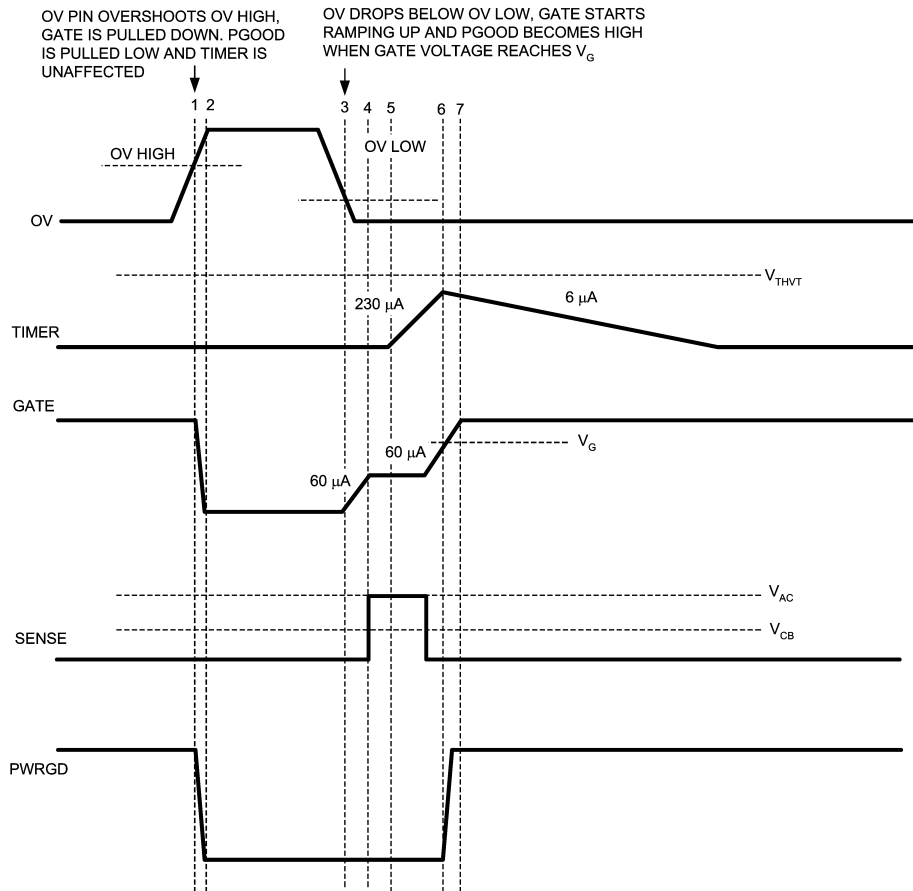

20078627

FIGURE 7. Over-Voltage Timing Behavior

During normal operation, if the OV pin exceeds OV HIGH, as shown at time point 1 in the above diagram, the TIMER status is unaffected. The GATE and PWRGD (for LM5068-1 & -2) pins are pulled low and the load is disconnected. At

time point 2, OV recovers and drops below the OV LOW threshold, the GATE start-up cycle begins. If the load capacitor is completely depleted during OV conditions, a full start-up cycle is initiated.

Timing Diagrams (Continued)

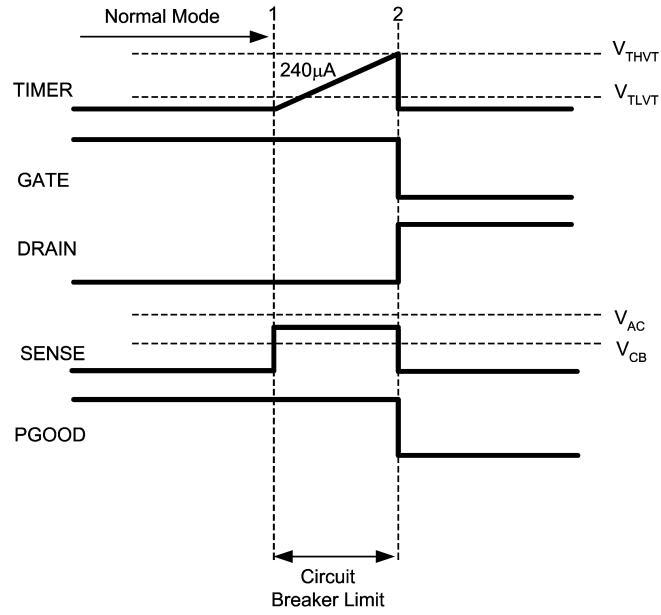

20078628

FIGURE 8. Circuit Breaker Current Limit Fault

The above timing waveform shows the circuit breaker current limit fault behavior. The timer capacitor is charged with $240\mu\text{A}$ when the SENSE pin exceeds V_{CB} . If the SENSE pin drops below V_{CB} before the TIMER reaches V_{THVT} , the timer

capacitor will be discharged with $6\mu\text{A}$. In the above figure when TIMER exceeds V_{THVT} , GATE is pulled low immediately to disconnect power to the load.

Timing Diagrams (Continued)

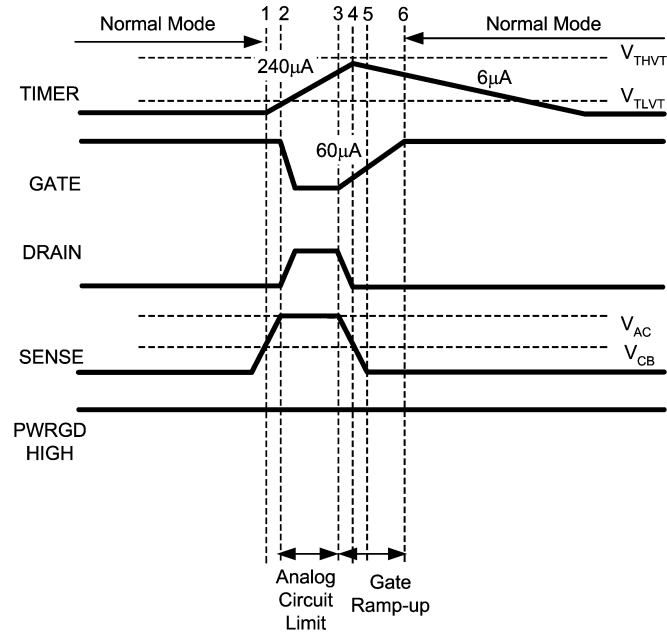

20078629

FIGURE 9. Analog Current Limit Fault

The above diagram shows analog current limit behavior when the SENSE pin voltage exceeds V_{AC} for a period of time, which activates the Analog Current Limit but never reaches the fault timer threshold. At that time the GATE is regulated by the analog current limit amplifier loop. When the

SENSE voltage falls below V_{AC} , GATE is allowed to charge with a 60µA current source. A compensation circuit consisting of a resistor and a capacitor in series, connected between GATE and V_{EE} stabilizes the current limit loop.

Timing Diagrams (Continued)

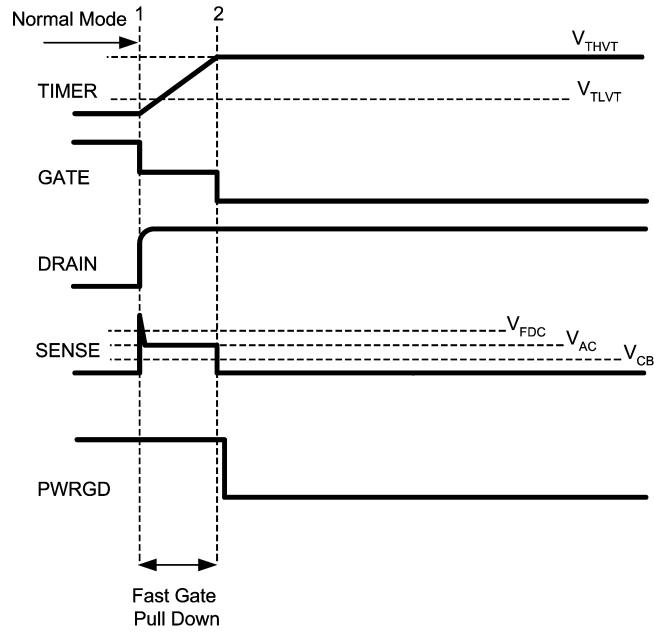

20078630

FIGURE 10. Fast Current Limit Fault

In case of a severe fault (for example sudden short-circuit of the output load) the SENSE pin exceeds the V_{FDC} threshold and GATE immediately pulls down until the Active Current Limit loop establishes control of the current in the MOSFET.

Careful selection of TIMER capacitor and MOSFET with adequate current and voltage ratings will prevent damage to MOSFET low impedance faults.

Timing Diagrams (Continued)

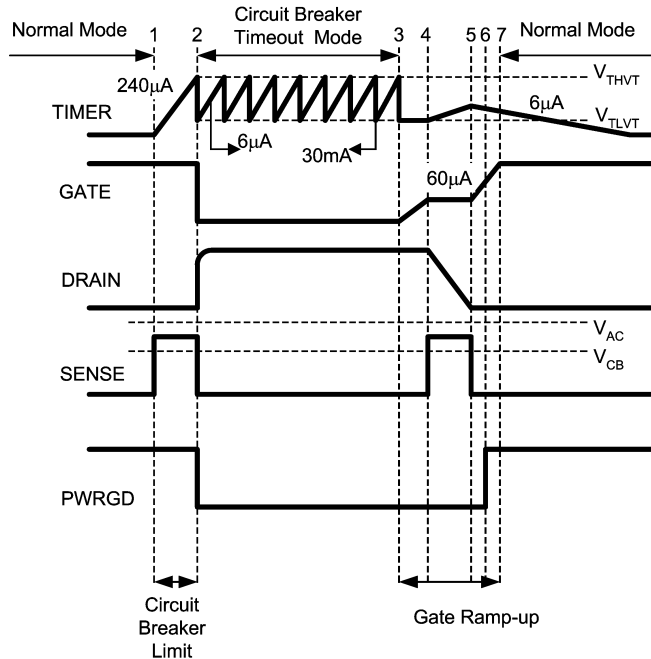

20078631

FIGURE 11. Shutdown Cooling Timing Behavior

Figure 11 shows the timer behavior for LM5068-2, -4 during fault re-try time. During normal operation, whenever the SENSE pin exceeds the 50mV, circuit breaker fault limit, the timer capacitor begins to charge. If the TIMER pin voltage exceeds 4V, the GATE is pulled down immediately, and LM5068-2, -4 disconnects power to the load. The TIMER

starts the fault re-try cycle by discharging C_T with 30mA to the V_{TLVT} threshold. The TIMER then charges C_T with 6μA to the V_{THVT} threshold. After eight charging phases and nine discharging phases, LM5068-2, -4 initiates an automatic retry start-up cycle.

Evaluation Board Schematic

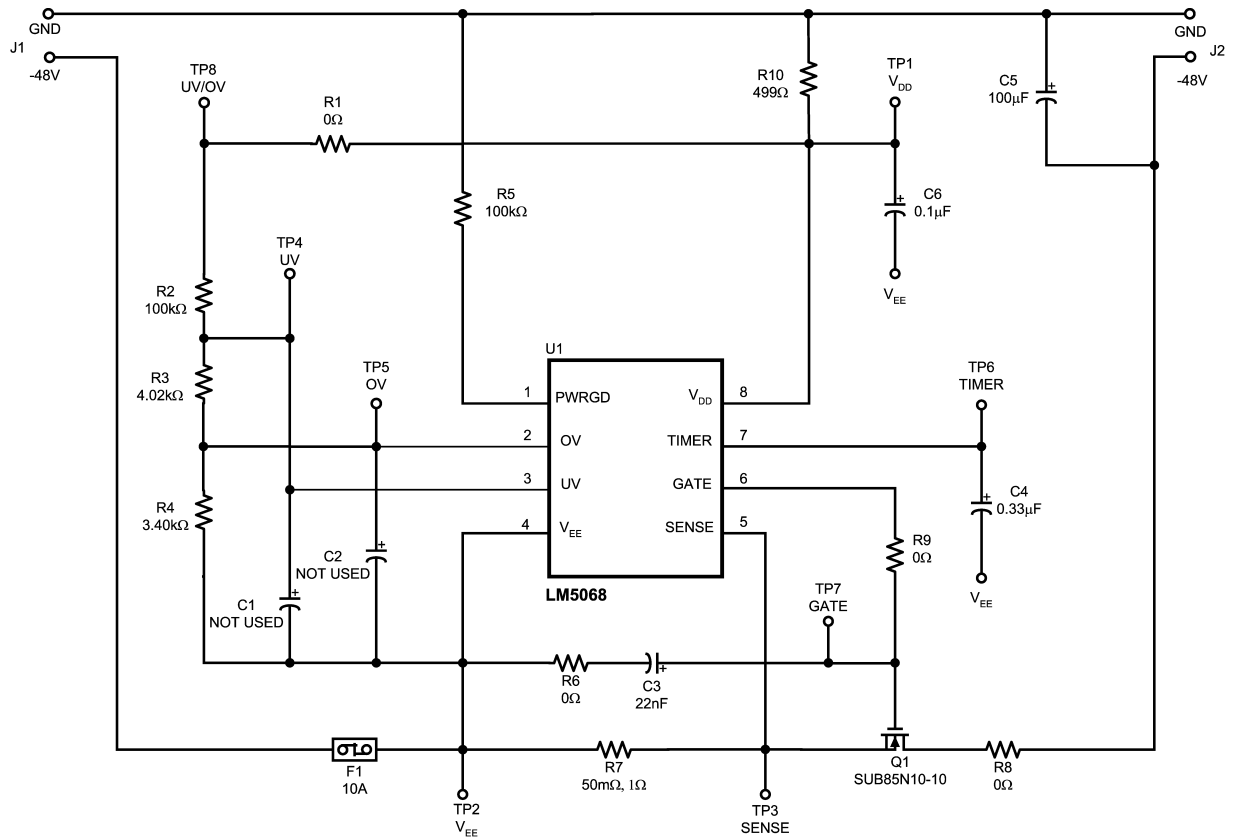

20078657

PART	VALUE	PACKAGE	DESCRIPTION	PART NUMBER
C1	NOT USED			
C2	NOT USED			
C3	0.022uF / 50V	C0805	CAPACITOR, CERAMIC, KEMET	C0805C223K5RAC
C4	0.33uF / 50V	C0805	CAPACITOR, CERAMIC, KEMET	C0805C334K5RAC
C5	100uF / 100V		CAPACITOR, ALUMINIUM ELECTROLYTIC, SURFACE MOUNT, PANASONIC	EEV-FK2A101M
C6	0.1uF / 100V	C1206	CAPACITOR, CERAMIC, TDK	C3216X7R2A104KT
F1	10A FUSE	SMD_FUSE	COOPER BUSSMAN FAST ACTING FUSE TRON	TR/SFT-10 (Digikey # 283-2439-2-ND)
J1	PCB terminal Blocks/ 10A		MOUSER TERMINAL BLOCKS	651-1727010
J2	PCB terminal Blocks/ 10A		MOUSER TERMINAL BLOCKS	651-1727010
Q1	100V / 60A	N-Channel Power MOSFET, TO263	VISHAY	SUB85N10-10
R1	0	R1206	SMD RESISTOR, 1% TOL	CRCW12060000F
R2	100K	R1206	SMD RESISTOR, 1% TOL	CRCW12061003F
R3	4.02K	R0805	SMD RESISTOR, 1% TOL	CRCW08053401F
R4	3.04K	R0805	SMD RESISTOR, 1% TOL	CRCW08053040F
R5	100K	R0805	SMD RESISTOR, 1% TOL	CRCW08051003F
R6	0	R0805	SMD RESISTOR, 1% TOL	CRCW08050000F
R7	50m	R2512	SMD RESISTOR, 1% TOL	WSL-2512 .050F
R8	0	R1206	SMD RESISTOR, 1% TOL	CRCW12060000F
R9	0	R1206	SMD RESISTOR, 1% TOL	CRCW12060000F
R10	499	R1206	SMD RESISTOR, 1% TOL	CRCW1206499RF

Evaluation Board Schematic (Continued)

PART	VALUE	PACKAGE	DESCRIPTION	PART NUMBER
U1	LM5068	MSOP-8	National Semiconductor	LM5068

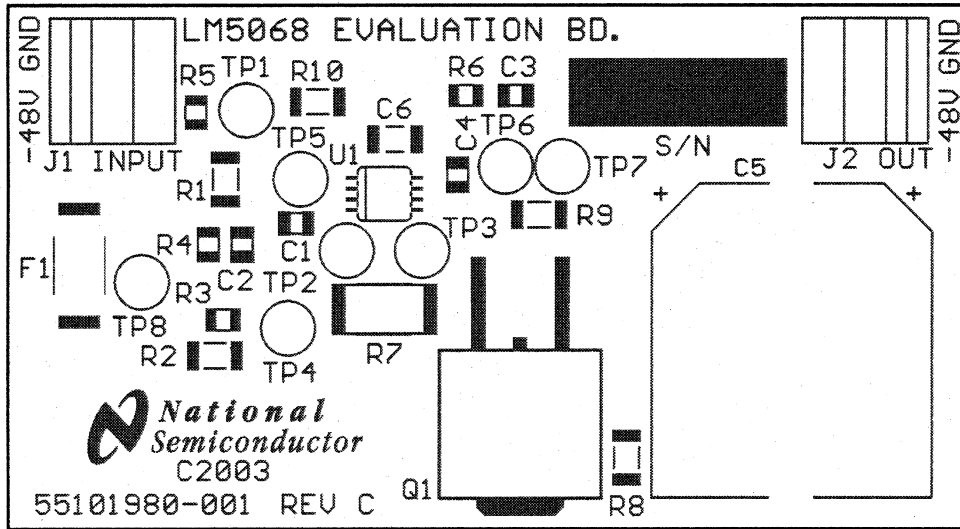

SILKSCREEN (PLACE) LAYER AS VIEWED FROM TOP

20078660

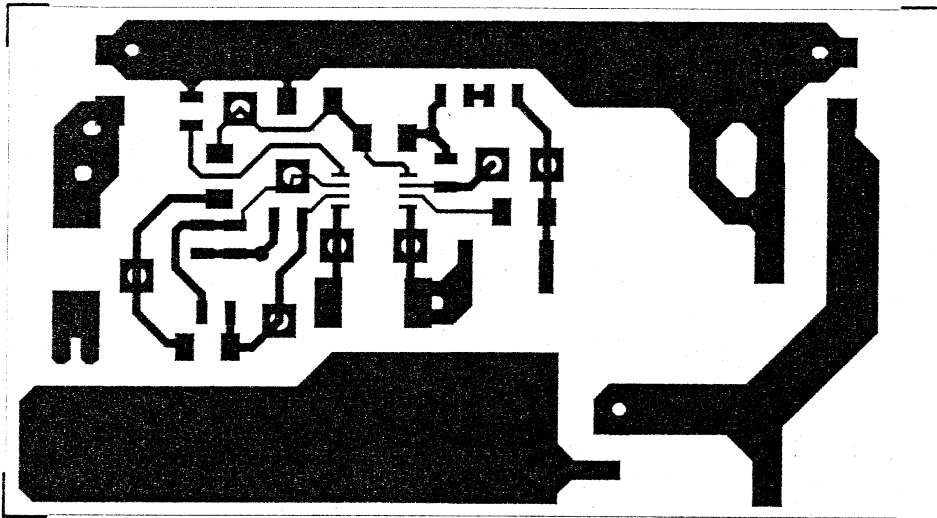

TOP (COMPONENT) LAYER AS VIEWED FROM TOP

20078661

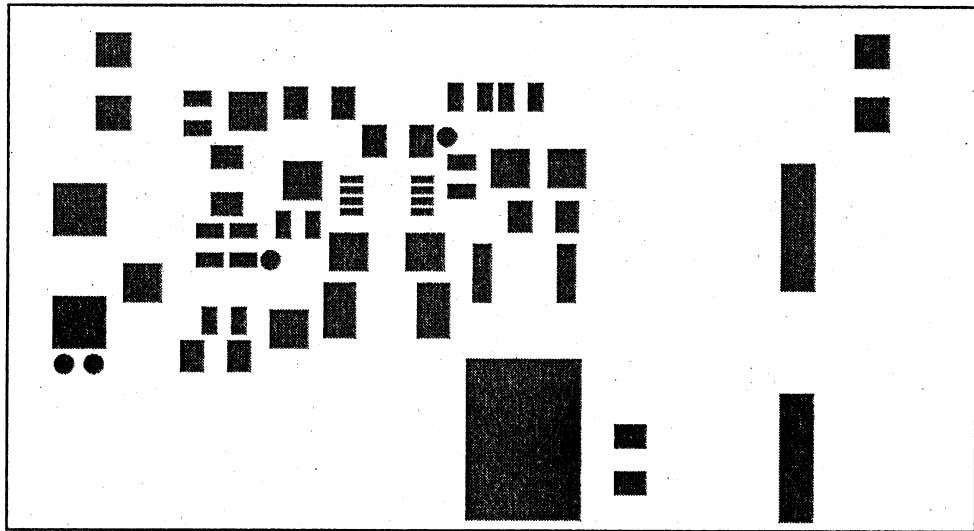

TOP SIDE SOLDERMASK AS VIEWED FROM TOP

20078662

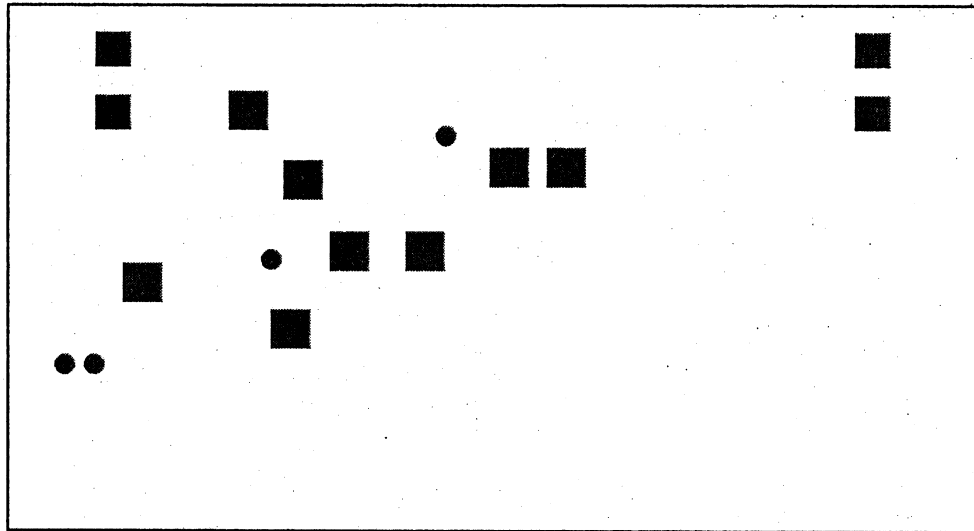

BOTTOM SIDE SOLDERMASK AS VIEWED FROM TOP

20078673

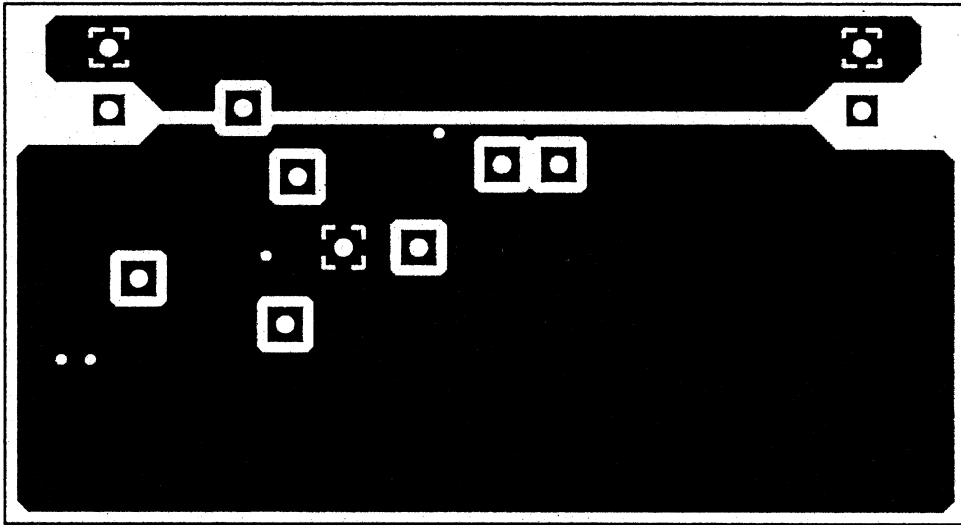

BOTTOM (SOLDER) LAYER AS VIEWED FROM TOP

20078674

Physical Dimensions inches (millimeters) unless otherwise noted

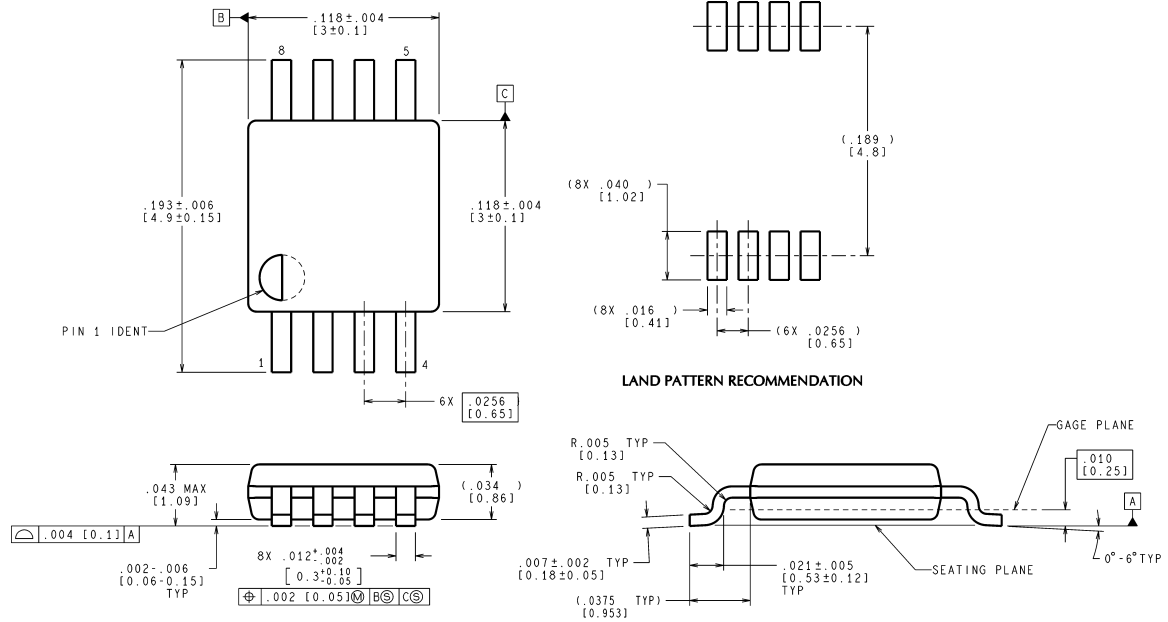

CONTROLLING DIMENSION IS INCH
VALUES IN [] ARE MILLIMETERS

MUA08A (Rev E)

Package Number MU08A

LIFE SUPPORT POLICY

NATIONAL'S PRODUCTS ARE NOT AUTHORIZED FOR USE AS CRITICAL COMPONENTS IN LIFE SUPPORT DEVICES OR SYSTEMS WITHOUT THE EXPRESS WRITTEN APPROVAL OF THE PRESIDENT AND GENERAL COUNSEL OF NATIONAL SEMICONDUCTOR CORPORATION. As used herein:

1. Life support devices or systems are devices or systems which, (a) are intended for surgical implant into the body, or (b) support or sustain life, and whose failure to perform when properly used in accordance with instructions for use provided in the labeling, can be reasonably expected to result in a significant injury to the user.
2. A critical component is any component of a life support device or system whose failure to perform can be reasonably expected to cause the failure of the life support device or system, or to affect its safety or effectiveness.

BANNED SUBSTANCE COMPLIANCE

National Semiconductor certifies that the products and packing materials meet the provisions of the Customer Products Stewardship Specification (CSP-9-111C2) and the Banned Substances and Materials of Interest Specification (CSP-9-111S2) and contain no "Banned Substances" as defined in CSP-9-111S2.

National Semiconductor
Americas Customer Support Center
Email: new.feedback@nsc.com
Tel: 1-800-272-9959

National Semiconductor
Europe Customer Support Center
Fax: +49 (0) 180-530 85 86
Email: europe.support@nsc.com
Deutsch Tel: +49 (0) 69 9508 6208
English Tel: +44 (0) 870 24 0 2171
Français Tel: +33 (0) 1 41 91 8790

National Semiconductor
Asia Pacific Customer Support Center
Email: ap.support@nsc.com

National Semiconductor
Japan Customer Support Center
Fax: 81-3-5639-7507
Email: jpn.feedback@nsc.com
Tel: 81-3-5639-7560

www.national.com