

M4 THREAD FOR LID
SCREWS 4 PLACES

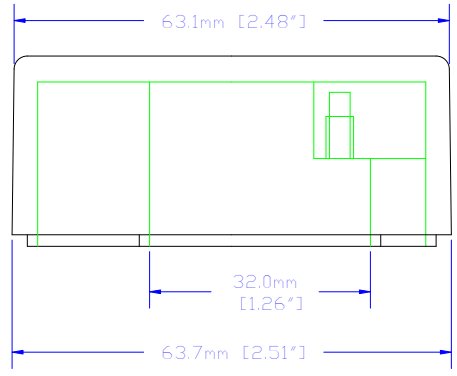

NOTES

DESIGNED TO MEET THE REQUIREMENTS OF IP65, & NEMA 4X
TONGUE & GROOVE CONSTRUCTION WITH A MOLDED ONE PIECE SILICON GASKET.
COMES WITH 4 STAINLESS STEEL MACHINE LID SCREWS, CAPTIVATED WITH 4 RUBBER O-RINGS.
COMES WITH 2 GROUNDING SCREWS AND WASHERS.
FINISH: NONE OR SUFFIX "BK" BLACK, OR SUFFIX "GY" GRAY (RAL 7001) POLYESTER POWDER

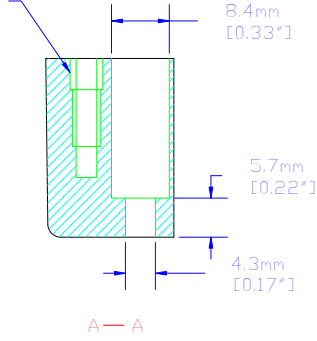
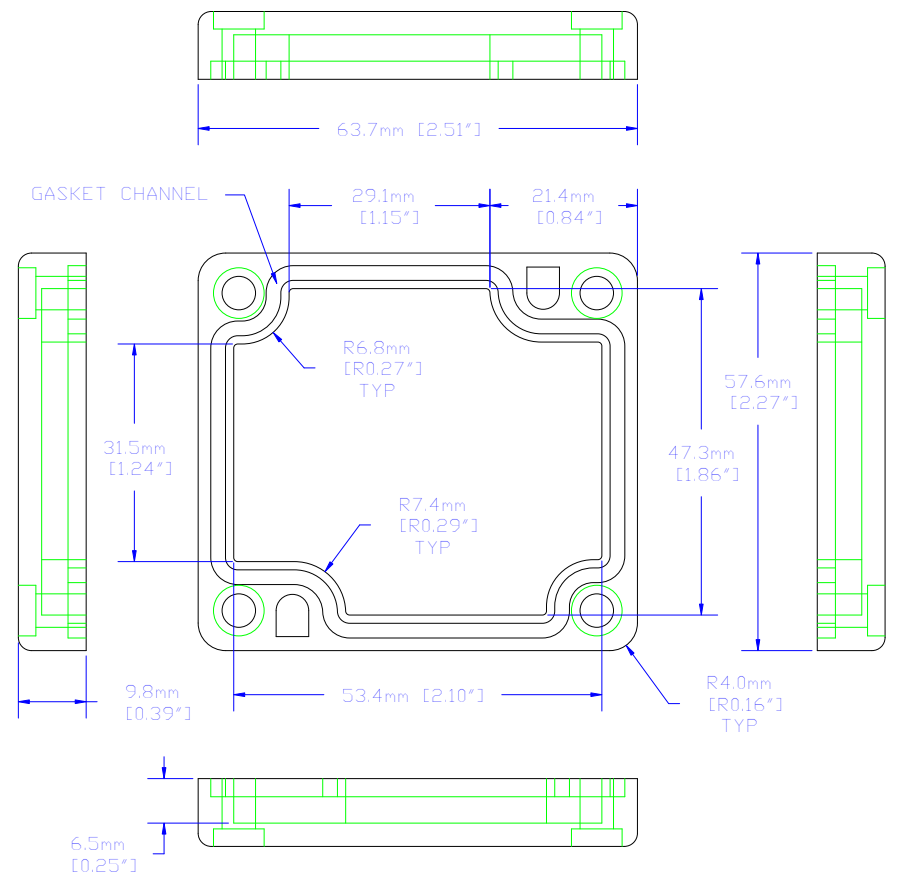
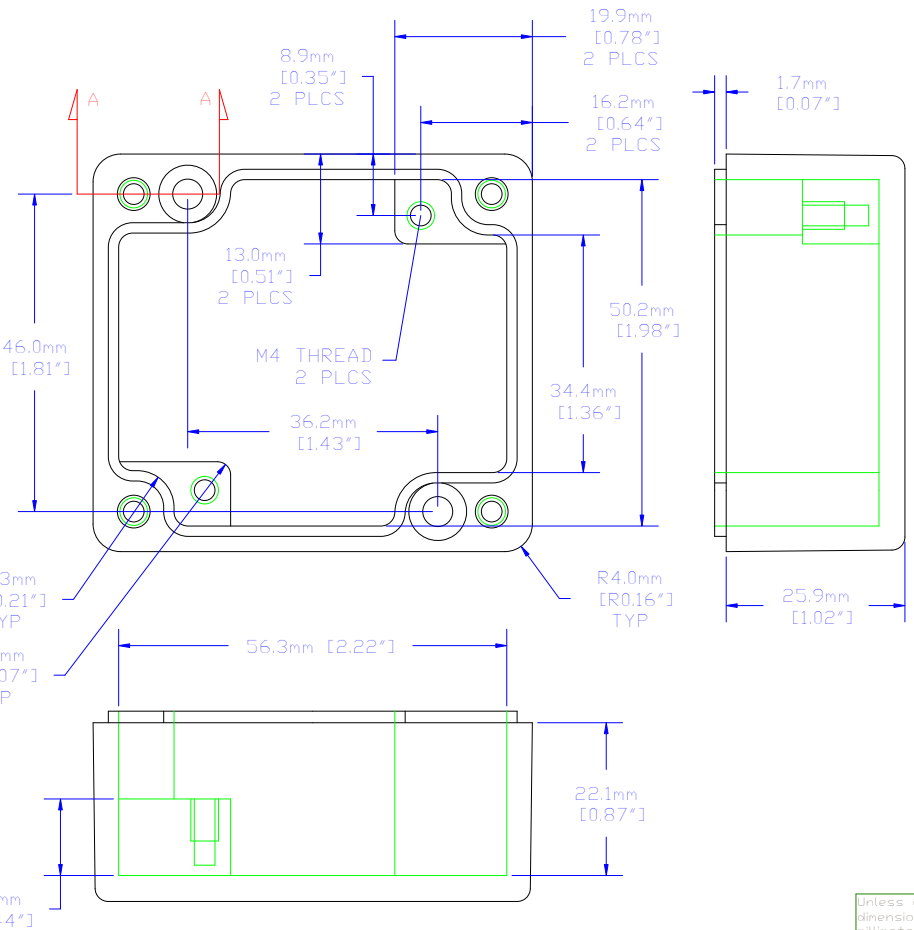
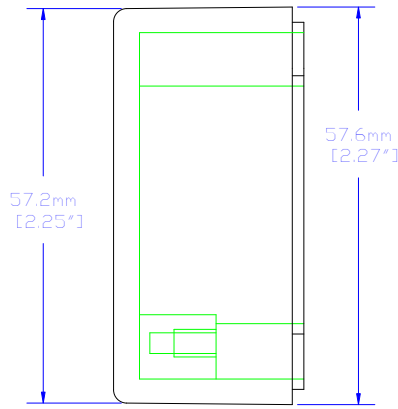

LID

For the best fit print
on legal size paper.

SIDE VIEWS DO NOT DETAIL
SCREW CHANNELS SEE
"A - A" FOR CHANNEL DETAIL

BOX

THIS DRAWING IS PROPRIETARY INFORMATION OF
HAMMOND MFG.CO.LTD. NOT TO BE USED WITHOUT
EXPRESSED WRITTEN PERMISSION
OF HAMMOND MFG.CO.LTD.

△	N/A	RELEASE	---	10/10/02	MJM
Rev	ECN	Description		Date	By

Unless otherwise spec'd dimensions are in millimeters Tolerances are:		Dwn	M. MERCER
X	±2.5	Date	10/10/02
.XX	±1.50	Chk	---
.XXX	±.500	Mat'l	CAST ALUMINUM
.XXXX	±.1300		
Holes	±.1300	Sheet	1 of 1
Angles	±5°	Part #	1590Z061

HAMMOND MANUFACTURING CO. LTD. Electronics Group, Waterloo, Ont. - Cheektowaga, NY	
HAMMOND 1590Z SERIES CASTED AL ENCLOSURES	
Dwg:	1590Z061/A