



Inductors

Transponder coils

Series/Type: B82450
Date: August 2006



Size 11.4 x 3.5 x 2.4 mm
Rated inductance 1 ... 7 mH

Construction

- Ferrite core
- Winding: enamel copper wire
- Moulded
- High mechanical resistance
- RoHS-compatible
- Suitable for lead-free reflow soldering profiles, e.g. JEDEC J-STD-020C



Terminals

- Tinned

Delivery mode

24-mm blister tape, wound on reel

General technical data

Rated inductance L_R	Measured with HP 4294A, test fixture HP 16034, measuring voltage 0.5 V _{rms} at frequency f_L @ 20°C
f_{res}	Measured with network analyser HP 8753
Q factor	Measured with HP 4294A, test fixture HP 16034, measuring voltage 0.5 V _{rms} at frequency f_Q @ 20°C
Sensitivity S_{typ}	Measured with Helmholtz coil test setup, $f=125kHz$
Climatic category	In accordance with IEC 60068-1: 40/125/56 (-40 °C/ +125 °C/ 56 days damp heat test)
Solderability	3 s, 245 °C, wetting >90%
Soldering	Suitable for lead-free reflow soldering profiles e.g. like shown in JEDEC J-STD-020C
DC resistance R_{max}	Measured at 20 °C ambient temperature
Weight	Approx. 0.32 g

SMD

Dimensional drawing

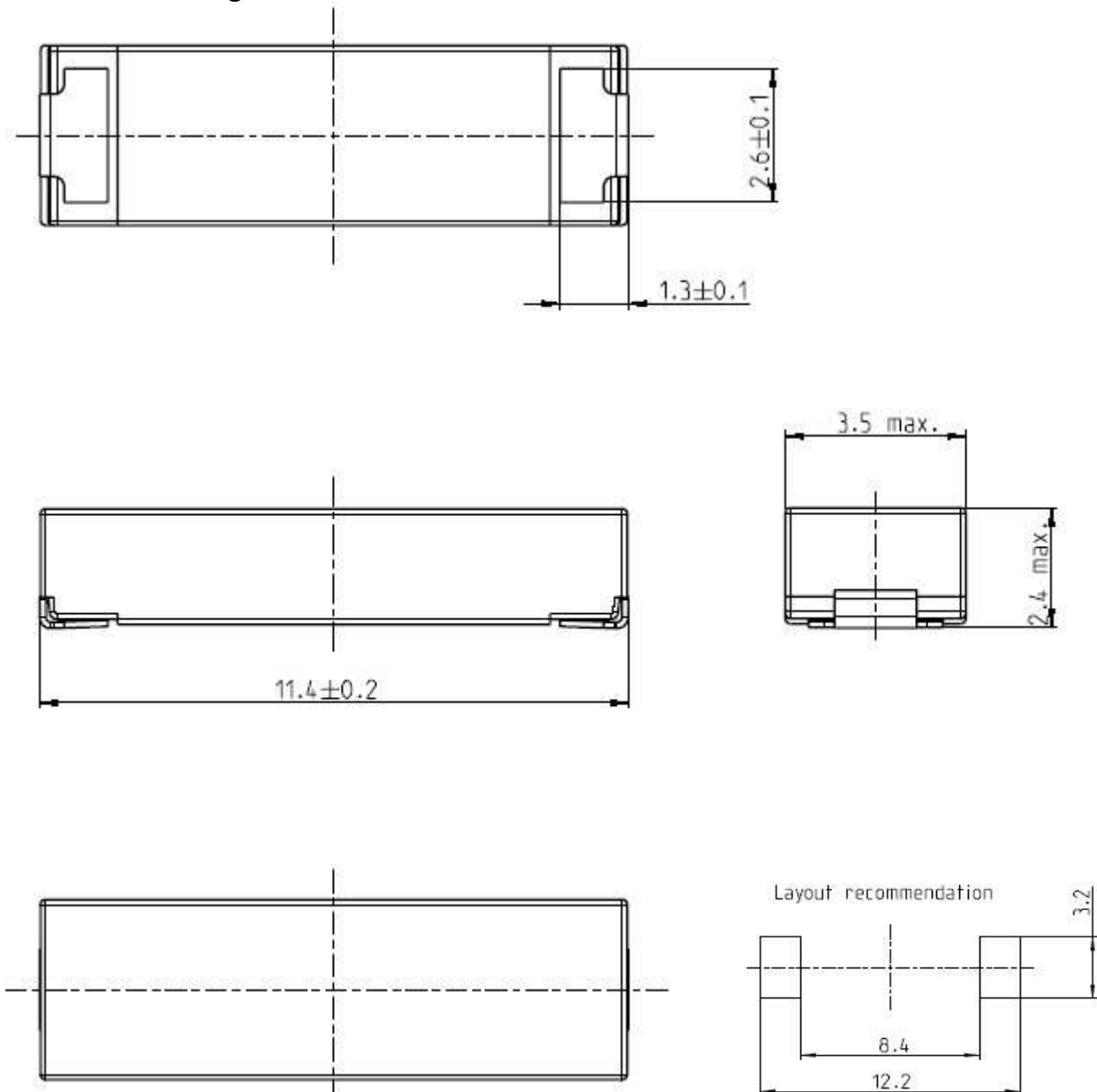

All dimensions in mm

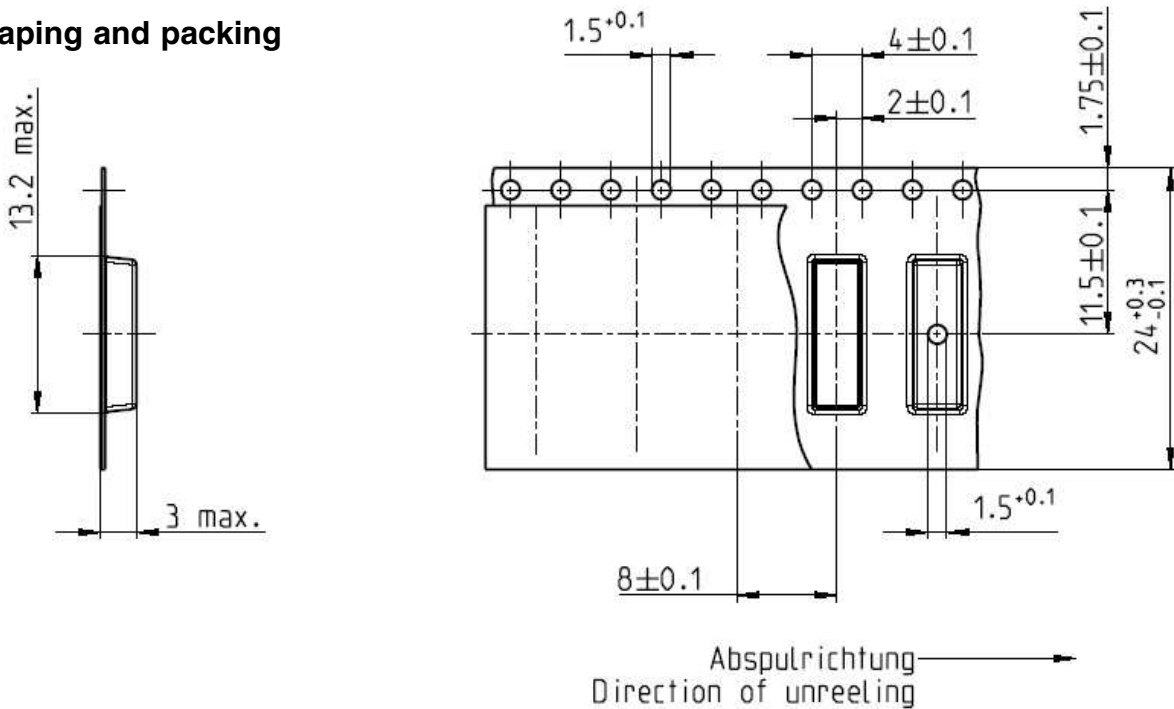
SMD
Taping and packing

Characteristics and ordering code

L_R	f_L, f_Q	Tolerance	Q_{min}	f_{res}	S_{typ}	R_{max}	Preliminary Ordering code
mH	kHz			kHz	mV/A/m	Ω	
1	125	$\pm 3\%$	33	>2700	20	15	B82450A1004A000
2.36	125	$\pm 3\%$	34	>2000	37	25	B82450A2364A000
7	125	$\pm 3\%$	34	>1100	60	70	B82450A7004A000

Characteristics and ordering code for other L values available on request.

Important notes

The following applies to all products named in this publication:

1. Some parts of this publication contain **statements about the suitability of our products for certain areas of application**. These statements are based on our knowledge of typical requirements that are often placed on our products in the areas of application concerned. We nevertheless expressly point out **that such statements cannot be regarded as binding statements about the suitability of our products for a particular customer application**. As a rule, EPCOS is either unfamiliar with individual customer applications or less familiar with them than the customers themselves. For these reasons, it is always ultimately incumbent on the customer to check and decide whether an EPCOS product with the properties described in the product specification is suitable for use in a particular customer application.
2. We also point out that **in individual cases, a malfunction of passive electronic components or failure before the end of their usual service life cannot be completely ruled out in the current state of the art, even if they are operated as specified**. In customer applications requiring a very high level of operational safety and especially in customer applications in which the malfunction or failure of a passive electronic component could endanger human life or health (e.g. in accident prevention or life-saving systems), it must therefore be ensured by means of suitable design of the customer application or other action taken by the customer (e.g. installation of protective circuitry or redundancy) that no injury or damage is sustained by third parties in the event of malfunction or failure of a passive electronic component.
3. **The warnings, cautions and product-specific notes must be observed.**
4. In order to satisfy certain technical requirements, **some of the products described in this publication may contain substances subject to restrictions in certain jurisdictions (e.g. because they are classed as “hazardous”)**. Useful information on this will be found in our Material Data Sheets on the Internet (www.epcos.com/material). Should you have any more detailed questions, please contact our sales offices.
5. We constantly strive to improve our products. Consequently, **the products described in this publication may change from time to time**. The same is true of the corresponding product specifications. Please check therefore to what extent product descriptions and specifications contained in this publication are still applicable before or when you place an order.

We also **reserve the right to discontinue production and delivery of products**. Consequently, we cannot guarantee that all products named in this publication will always be available.

6. Unless otherwise agreed in individual contracts, **all orders are subject to the current version of the “General Terms of Delivery for Products and Services in the Electrical Industry” published by the German Electrical and Electronics Industry Association (ZVEI)**.
7. The trade names EPCOS, EPCOS-JONES, Baoke, CeraDiode, CSSP, MLSC, SIFI, PhaseCap, PhaseMod, SIFERRIT, SIKOREL, SilverCap, SIMID, SIOV, SIP5D, SIP5K, UltraCap, WindCap are **trademarks registered or pending** in Europe and in other countries. Further information will be found on the Internet at www.epcos.com/trademarks.