

**Excerpt from
our master catalogue**

PCB terminals

wiecon

In general, all Wieland components which are obliged to have the **CE** identification are provided with the **CE** mark

Pluggable PCB terminals and headers

Two part PCB terminals with pin strip headers

Modular railmount terminals with integral

PCB edge connectors

PCB terminals

2 tier PCB terminals

3 tier PCB terminals

4 tier PCB terminals

Special terminals

RAST 5 system
Termination modules
Marker tag/strips

	<p>Pitch 3.50/3.81 mm</p> <ul style="list-style-type: none"> • Terminal connector, rising cage clamp version Page 280 • Terminal connector, spring clamp version Page 281 • Header Page 284 <p>Pitch 5.00/5.08/7.50/7.62 mm</p> <ul style="list-style-type: none"> • Terminal connector, rising cage clamp version Page 286 • Header with in-line terminal spring clamp version (= inverted socket) Page 295 • Terminal connector, spring clamp version Page 294 • Terminal connector, soldered version Page 295 • Headers Page 297 • TOP plug with strain relief Page 320
	<p>Pitch 3.50/5.00 mm screw version Page 316</p> <p>Pitch 3.50 mm spring clamp version Page 324</p>
header	<p>Pitch 5.00 mm modular railmount terminals with integral header Page 310</p>
	<p>Pitch 3.50 mm rising cage clamp version Page 328</p> <p>Pitch 5.00 mm rising cage clamp version Page 330</p>
	<p>Pitch 3.50/3.81 mm</p> <ul style="list-style-type: none"> • rising cage clamp version Page 280 <p>Pitch 5.00/5.08 mm</p> <ul style="list-style-type: none"> • rising cage clamp version Page 286 • spring clamp version Page 292 <p>Pitch 6,35 mm</p> <p>Pitch 7.50/7.62 mm</p> <ul style="list-style-type: none"> • rising cage clamp version Page 288 • spring clamp version Page 294 <p>Pitch 10.00/10.16 mm</p> <ul style="list-style-type: none"> • rising cage clamp version Page 318, 375, 377
	<p>Pitch 5.00/5.08 mm</p> <ul style="list-style-type: none"> • rising cage clamp version Page 364
	<p>Pitch 5.00/5.08 mm</p> <ul style="list-style-type: none"> • rising cage clamp version Page 370
	<p>Pitch 5.00 mm</p> <ul style="list-style-type: none"> • rising cage clamp version Page 373
	<p>Pitch 5.08 mm</p> <ul style="list-style-type: none"> • Modular terminal Page 378 • Disconnect terminal Page 378 • Modular fuse terminal Page 379 • ASI connector Page 392
	<p>Page 380</p> <p>Page 386</p> <p>Page 394</p>

Pluggable PCB terminals and headers









		Page 298	Page 301	Page 299	Page 299	Page 301	Page 297	Page 300	Page 297	Page 298	
		Pitch	5.00/5.08	7.50/7.62	5.00/5.08	5.00/5.08	7.50/7.62	5.00/5.08	7.50/7.62	5.00/5.08	5.00/5.08
			8113 S/W 8213 S/W	8313 S/W 8413 S/W	8113 S/WOF 8213 S/WOF	8113 S/WF 8213 S/WF	8313 S/WF 8413 S/WF	8113 S/G 8213 S/G	8313 S/G 8413 S/G	8113 S/GOF 8213 S/GOF	8113 S/GF 8213 S/GF
		Pole	2 – 24	2 – 12	2 – 24	2 – 22	2 – 12	2 – 24	2 – 12	2 – 24	2 – 22
	Page 291 8113 BK	5.00	● 8113		● 8113			● 8113		● 8113	
	Page 286 8113 B 8213 B	5.00 5.08	●		●			●		●	
	Page 292 8113 BFK 8213 BFK	5.00 5.08	●		●	●		●		●	
	Page 287 8213 B/S	5.08						● 8213		● 8213	
	Page 288 8313 B 8413 B	7.50 7.62		●					●		
	Page 286 8113 B/F 8213 B/F	5.00 5.08				●					●
	Page 288 8313 B/F 8413 B/F	7.50 7.62					●				
	Page 289 8113 B/VL 8213 B/VL	5.00 5.08	●		●			●		●	
	Page 289 8113 B/VR 8213 B/VR	5.00 5.08	●		●			●		●	
	Page 290 8413 B/VL	7.62		●					●		
	Page 290 8413 B/VR	7.62		●					●		
	Page 296 8113 B/TOP 8213 B/TOP	5.00 5.08	●		●			●		●	
	Page 295 8213 BL/G	5.08	●		●			●		●	
	Page 295 8213 BL/W	5.08	●		●			●		●	

wiecon

Page 300	Page 302	Page 302	Page 293	Page 303	Page 303	Page 305	Page 305	Page 305	Page 305	Page 304	Page 304
7.50/7.62	5.00/5.08	5.00/5.08	5.08	5.00/5.08	5.00/5.08	5.08	5.08	5.08	5.08	5.00/5.08	5.00/5.08
8313 S/GF 8413 S/GF	8113 S/S 8213 S/S	8113 S/S1 8213 S/S1	8213 SUFK	8113 SE/W 8213 SE/W	8113 SE/G 8213 SE/G	8213 S/ DFWW	8213 S/ DFWWM	8213 S/ DFLS	8213 S/ DFLSM	8113 SEG/W 8213 SEG/W	8113 SEG/G 8213 SEG/G
2 - 12	2 - 24	2 - 24	2 - 12 (24)	2 - 24 slot together	2 - 24 slot together	2 - 24	2 - 22 with nut	2 - 24	2 - 22 with nut	2 - 24	2 - 24
	● 8113	● 8113		● 8113	● 8113					● 8113	● 8113
	●	●	● 8213	●	●	●		●		●	●
	●	●	● 8213	●	●	●	●	● 8213	●	●	●
	● 8213	● 8213	●	● 8213	●	●		●	● 8213		● 8213
			● 8213				●		●	●	●
	●										
	●	●	● 8213	●	●	●	●	● 8213	● 8213	●	●
	●	●	● 8213	●	●	●	●	● 8213	● 8213	●	●
	●	●	● 8213	●	●	●	●	●		●	●
	●	●	● 8213	●	●	●	●	●		● 8213	● 8213
			● 8213								

Pluggable PCB terminals and modular railmount terminals

wiecon PCB

		Page 310	Page 310	Page 311	Page 312	Page 312	Page 308
		5.00	5.00	7.50	5.00	7.50	5.00
Pitch	5.00/7.50 mm	2 – 24 slot together		2 – 12 slot together	2 – 24 slot together	2 – 12 slot together	2 – 24 slot together
	Page 286 8113 B	5.00	2 – 24	●	●	●	
	Page 288 8313 B	7.50	2 – 12		●	●	
	Page 289 8113 B/VL	5.00	2 – 24	●	●	●	
	Page 289 8113 B/VR	5.00	2 – 24	●	●	●	
	Page 296 8113 B/TOP	5.00	2 – 24	●	●	●	
	Page 292 8113 BFK	5.00	2 – 24	●	●	●	●

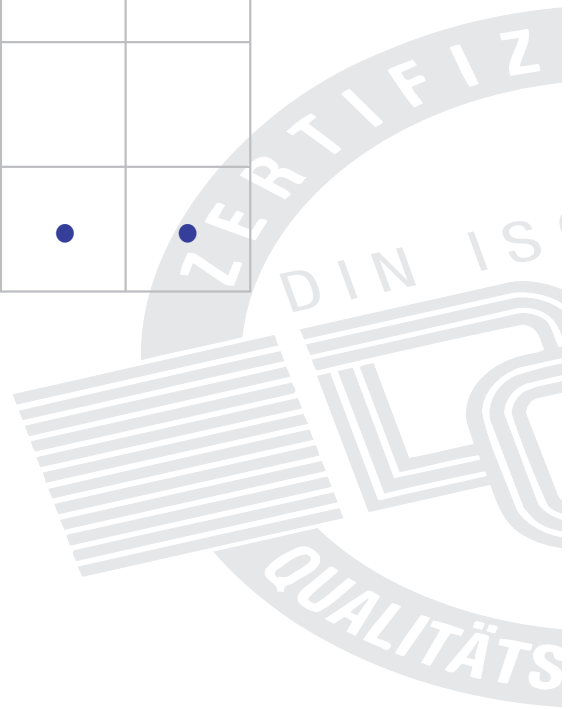

Reg.:

Pluggable PCB terminals and headers

wiecon

		Page 284	Page 285	Page 284	Page 285
Pitch	3.81 mm	3.50/3.81	3.50/3.81	3.50/3.81	3.50/3.81
Pitch	3.50 mm	8513 S/W 8813 S/W	8513 S/WF 8813 S/WF	8513 S/G 8813 S/G	8513 S/GF 8813 S/GF
		2 - 20	2 - 20	2 - 20	2 - 20
	Page 280 8513 B 8813 B	2 - 20			
	Page 280 8513 B/F 8813 B/F	2 - 20			
	Page 282 8813 B/VR	2 - 20			
	Page 282 8813 B/VL	2 - 20			
	Page 283 8813 B/VRF	2 - 20			
	Page 283 8813 B/VLF	2 - 20			
	Page 281 8513 BFK	2 - 20			



Pluggable PCB terminals and headers

wiecon PCB

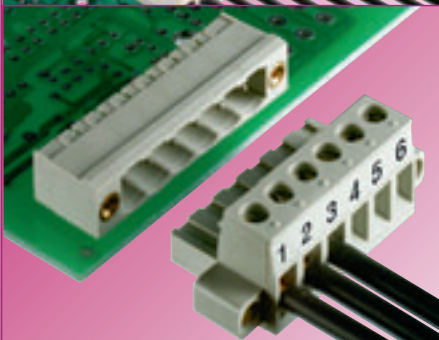
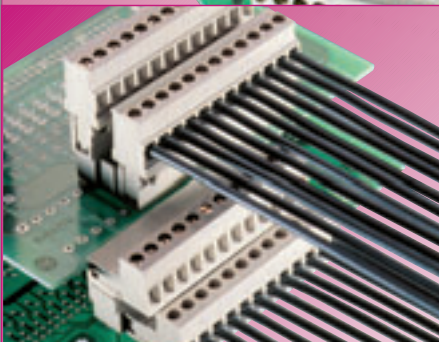
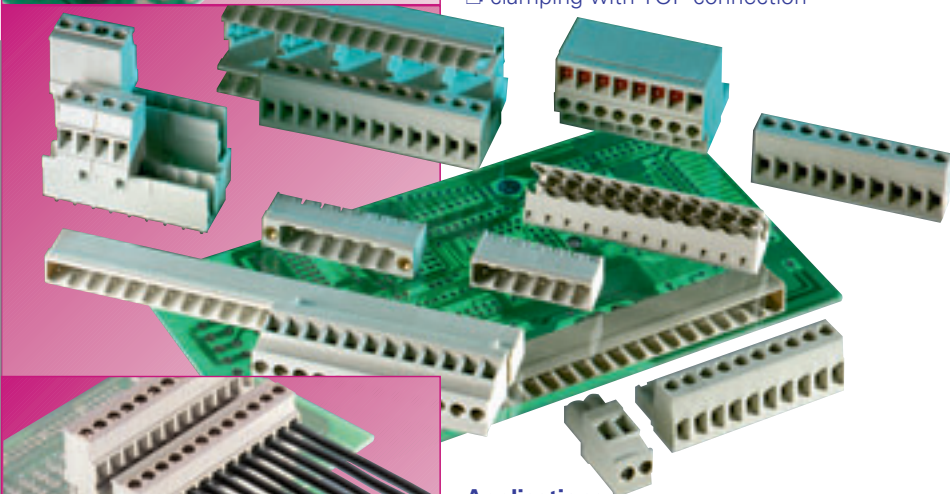

Pluggable connection describes the method used to connect an external conductor to a PCB, via a terminal connector and header

System features

- plug in system is simple to maintain
- screw termination by means of rising cage clamp for security
- screw connection is easy to operate
- spring clamp connection for speed
- comprehensive range means that the direction of insertion/withdrawal and conductor guide methodology can be individually matched to the application
- simple, clear and secure method of connecting and disconnecting
- multiple pole configuration
- connection of single core and finely stranded conductors up to 1.5 mm² and 2.5 mm²
- metric and imperial pitch options
The pitch measured in inches can be identified by a pip on the conductor guide funnel
- clamping with TOP connection

Applications

- designed for frequent and ongoing equipment maintenance and system changes as the pluggable terminal connector and PCB header are easily connected and disconnected
- prefabricated wiring arrangements can be easily interfaced to connect and enable the system

Type range

- 2 - 24 pole
- different variants of terminals and headers allow for horizontal, vertical and angled connection of wiring in relation to the PCB (eg. 35°)

- PCB terminals with closed side walls: ensure no miss-connection
- PCB terminals with open side walls enable expansion with no effect on the pitch to the circuit board
- pitch options: 3.81/5.00/5.08/7.50/7.62/10.00/10.16 mm
- two tier headers

Flange version

- terminal connectors and headers can also incorporate additional fixing elements such as screw flanges which helps prevent them being separated accidentally
- secure electrical and mechanical connection even under shock and vibration

Coding

- a coding system is available to prevent the connection of non-interchangeable components. The coding parts can be inserted into special slots in either or both the terminal connector and header
- coding does not effect number of available poles
- coding possible with a minimum of 4 poles

Marking

- clear pole marking which is easy to read enabling easy connection
- by means of ink jet printing directly onto the terminal connector using indelible ink
- special marking is possible on request

DQS certification for all product areas

- Quality standard in accordance with DIN ISO 9001
- In development, production and installation
- Continued control of the quality standard by means of regular internal and external quality audits
- Compatible with certificates of other countries:
 - BSI, Great Britain
 - SQS, Switzerland
 - Aib-Vincotte, Belgium
 - ÖQS, Austria

wiecon

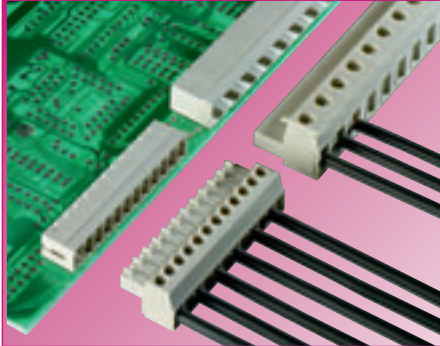

System 8813

- mini-PCB terminals 2 to 20 pole
- terminal and header horizontal or vertical in relation to the PCB
- total design height: 11 mm, of which only 8 mm is above the PCB
- in the space saving 3.81 mm pitch
- conductor size 1.5 mm²
- suitable for coding:
 - plug terminal with coding pins
 - socket header with coding channels
- also with locking flange

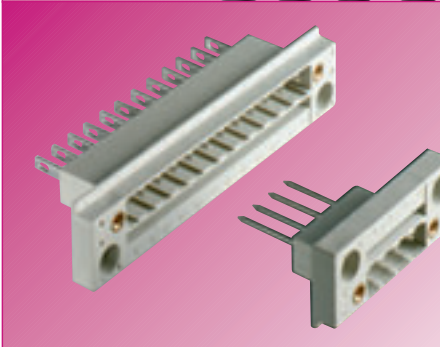

Panel mount header

- header can be inserted in the unit wall (see inset)
- plug in connection through the wall
- header = bush housing
- threaded bush for vibration resistant screw connection of flange designs
- can be screwed to the housing wall
- connecting wiring inside the housing via termi-point or solder connection

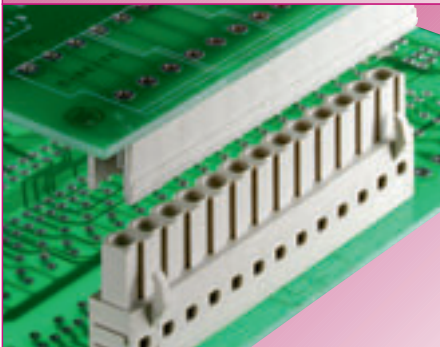

Inverted version

- solderable terminal as header with straight and angled socket solder pins
- can be coded using coding parts in special slots
- the mounting holder enables locking with the header

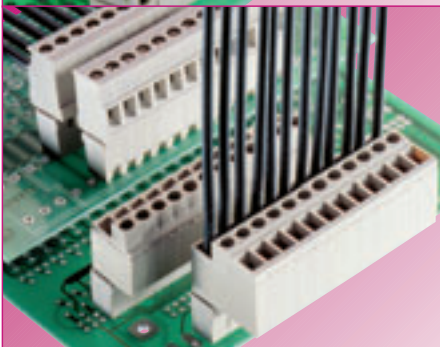

Top version

- screw connection and conductor feed in line with connection
- plug with connection in line with conductor
- very easy to use in restricted installation conditions
- with and without integral LED

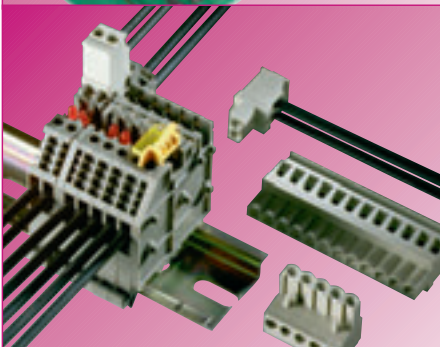

Special types

- for the control panel:
 - terminal blocks with integral header
 - assembles to 5.00 mm-pitch
 - can be mounted on DIN rail
- terminals with header for system 8113
- with vertical socket outlet
- with horizontal socket outlet

Materials

Metal components

- made from special alloys and/ or special surface treatments for:
- clamping part and clamping screw: made from nickel plated brass
top version: galvanised and chromated steel
- socket contact: tinned bronze
- header and solder pins: made from a high quality copper alloy
- minimum contact resistance
- high corrosion protection
- secure, dynamic clamping function

Insulating housing:

- Polyamide 66/6, used on account of its excellent electrical, chemical and mechanical properties (see **facts** & DATA section)
- material in accordance with UL 94 V-0
- colour grey, similar to RAL 7032
- glass filled for additional reinforcement (no glass reinforcement in tier-type header and solderable parts)

Abbreviations for plastic material markings:

- PA 66/6 = Polyamide 66/6
- PC = Polycarbonate
- PBT = Polybutylenterephthalate

Note:

The conductor size and connecting capacity relate to unprepared conductors without ferrules.

The rated current specified corresponds to the maximum load of PCB terminal with connected conductor with the given conductor size.

The rated voltage is specified in accordance with DIN VDE 0110 Part 1 (IEC 60 664-1) – Insulation coordination for electrical equipment in low voltage installations and refers to the received condition of the PCB terminals.

When fitting PCB terminals to the PCB, the appropriate PCB must be selected and given the relevant dimensions (e.g. as regards the resistance of the PCB to creepage, spacing of the conductors and soldering pads).

In addition, the influences of the environment (level of pollution) to which the equipment is to be exposed are to be taken into account. The specified rate voltages for the whole module only apply if the PCB and PCB terminal have been matched correctly and carefully.

Pluggable PCB terminal, rising cage clamp system, pitch 3.50/3.81 mm

wiecon PCB

cable size
1.5 mm²

Rated cross section:
1.5 mm²

Rated current:
8 A

Wire range:
0.14 – 1.5 mm² single core/finely stranded

125 V/2.5 kV/3 – overvoltage category III
250 V/2.5 kV/2 – overvoltage category II
* 690 V/2.5 kV/1 – overvoltage category I

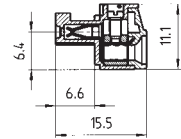
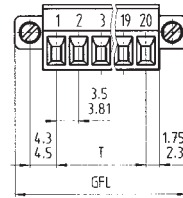
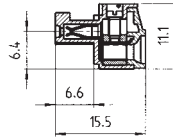
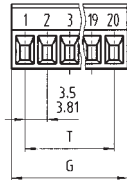

* max. 600V for non earthed systems or expected overvoltage
≤ 3 kV for L ≥ 2.00 mm and ≤ 2.5 kV for 2.0 mm > L ≥ 1.5 mm

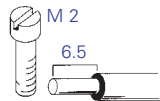

Type 8513 B/..., 8813 B/...

Connection in line with conductor

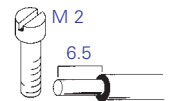

with screw flange

Type 8513 B/...F, 8813 B/...F

Connection in line with conductor

Rated voltages VDE 0110

UL Data

CSA Data

Approvals

No. 30 – 16 AWG

300 V

8 A

No. 22 – 14 AWG

300 V

5 A



No. 30 – 16 AWG

300 V

8 A

No. 22 – 14 AWG

300 V

5 A



Box Qty	GFL	G	T	Pole	Part No.	Part No.	Part No.	Part No.
Pitch 3.50 mm					unmarked	marked	unmarked	marked
100	17.40	7.00	3.50	2	25.640.3253.0	25.640.0253.0	25.641.3253.0	25.641.0253.0
100	20.90	10.50	7.00	3	25.640.3353.0	25.640.0353.0	25.641.3353.0	25.641.0353.0
50	24.40	14.00	10.50	4	25.640.3453.0	25.640.0453.0	25.641.3453.0	25.641.0453.0
50	27.90	17.50	14.00	5	25.640.3553.0	25.640.0553.0	25.641.3553.0	25.641.0553.0
50	31.40	21.00	17.50	6	25.640.3653.0	25.640.0653.0	25.641.3653.0	25.641.0653.0
50	34.90	24.50	21.00	7	25.640.3753.0	25.640.0753.0	25.641.3753.0	25.641.0753.0
50	38.40	28.00	24.50	8	25.640.3853.0	25.640.0853.0	25.641.3853.0	25.641.0853.0
50	41.90	31.50	28.00	9	25.640.3953.0	25.640.0953.0	25.641.3953.0	25.641.0953.0
50	45.40	35.00	31.50	10	25.640.4053.0	25.640.1053.0	25.641.4053.0	25.641.1053.0
50	48.90	38.50	35.00	11	25.640.4153.0	25.640.1153.0	25.641.4153.0	25.641.1153.0
50	52.40	42.00	38.50	12	25.640.4253.0	25.640.1253.0	25.641.4253.0	25.641.1253.0
50	55.90	45.50	42.00	13	25.640.4353.0	25.640.1353.0	25.641.4353.0	25.641.1353.0
50	59.40	49.00	45.50	14	25.640.4453.0	25.640.1453.0	25.641.4453.0	25.641.1453.0
50	62.90	52.50	49.00	15	25.640.4553.0	25.640.1553.0	25.641.4553.0	25.641.1553.0
50	66.40	56.00	52.50	16	25.640.4653.0	25.640.1653.0	25.641.4653.0	25.641.1653.0
Pitch 3.81 mm					unmarked	marked	unmarked	marked
100	18.01	8.41	3.81	2	25.620.3253.0	25.620.0253.0	25.621.3253.0	25.621.0253.0
100	21.82	12.22	7.62	3	25.620.3353.0	25.620.0353.0	25.621.3353.0	25.621.0353.0
50	25.63	16.03	11.43	4	25.620.3453.0	25.620.0453.0	25.621.3453.0	25.621.0453.0
50	29.44	19.84	15.24	5	25.620.3553.0	25.620.0553.0	25.621.3553.0	25.621.0553.0
50	33.25	23.65	19.05	6	25.620.3653.0	25.620.0653.0	25.621.3653.0	25.621.0653.0
50	37.06	27.46	22.86	7	25.620.3753.0	25.620.0753.0	25.621.3753.0	25.621.0753.0
50	40.87	31.27	26.67	8	25.620.3853.0	25.620.0853.0	25.621.3853.0	25.621.0853.0
50	44.68	35.08	30.48	9	25.620.3953.0	25.620.0953.0	25.621.3953.0	25.621.0953.0
50	48.49	38.89	34.29	10	25.620.4053.0	25.620.1053.0	25.621.4053.0	25.621.1053.0
50	52.30	42.70	38.10	11	25.620.4153.0	25.620.1153.0	25.621.4153.0	25.621.1153.0
50	56.11	46.51	41.91	12	25.620.4253.0	25.620.1253.0	25.621.4253.0	25.621.1253.0
50	59.92	50.32	45.72	13	25.620.4353.0	25.620.1353.0	25.621.4353.0	25.621.1353.0
50	63.73	54.13	49.53	14	25.620.4453.0	25.620.1453.0	25.621.4453.0	25.621.1453.0
50	67.54	57.94	53.34	15	25.620.4553.0	25.620.1553.0	25.621.4553.0	25.621.1553.0
50	71.35	61.75	57.15	16	25.620.4653.0	25.620.1653.0	25.621.4653.0	25.621.1653.0

Pluggable PCB terminals, spring clamp system, pitch 3.50 mm

witecon

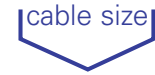

1.5 mm²

Rated cross section:
1.5 mm²

Rated current:
8 A

Wire range:
0.14 – 1.5 mm² single core/finely stranded

125 V/2.5 kV/3 – overvoltage category III
250 V/2.5 kV/2 – overvoltage category II
* 690 V/2.5 kV/1 – overvoltage category I

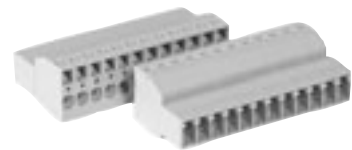
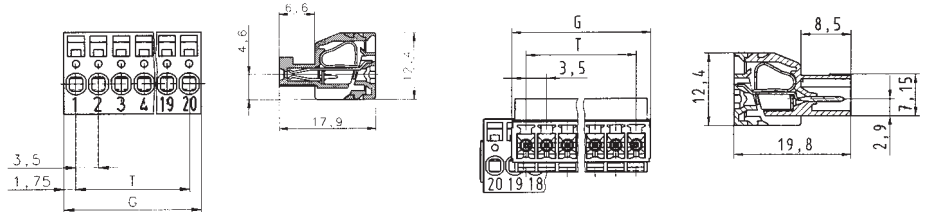

* max. 600V for non earthed systems or expected overvoltage
≤ 3 kV for L ≥ 2.00 mm and ≤ 2.5 kV for 2.0 mm > L ≥ 1.5 mm

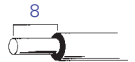

Type 8513 BFK

Type 8513 SUFK

VDE 0110
UL Data
CSA Data
Approvals

No. 30 – 16 AWG
No. 22 – 14 AWG

300 V 8 A
300 V 5 A



No. 30 – 16 AWG
No. 22 – 14 AWG

300 V 8 A
300 V 5 A



	Box Qty	G	T	Pole	Part No.	Part No.	Part No.	Part No.
Pitch 3.50 mm		Type 8513 BFK			unmarked	marked		
	100	6.90	3.50	2	25.630.3253.0	25.630.0253.0		
	100	10.40	7.00	3	25.630.3353.0	25.630.0353.0		
	50	13.90	10.50	4	25.630.3453.0	25.630.0453.0		
	50	17.40	14.00	5	25.630.3553.0	25.630.0553.0		
	50	20.90	17.50	6	25.630.3653.0	25.630.0653.0		
	50	24.40	21.00	7	25.630.3753.0	25.630.0753.0		
	50	27.90	24.50	8	25.630.3853.0	25.630.0853.0		
	50	31.40	28.00	9	25.630.3953.0	25.630.0953.0		
	50	34.90	31.50	10	25.630.4053.0	25.630.1053.0		
	50	38.40	35.00	11	25.630.4153.0	25.630.1153.0		
	50	41.90	38.50	12	25.630.4253.0	25.630.1253.0		
	50	45.40	42.00	13	25.630.4353.0	25.630.1353.0		
	50	48.90	45.50	14	25.630.4453.0	25.630.1453.0		
	50	52.40	49.00	15	25.630.4553.0	25.630.1553.0		
	50	55.90	52.50	16	25.630.4653.0	25.630.1653.0		
Pitch 3.50 mm		Type 8513 SUFK					unmarked	marked
	100	8.40	3.50	2			25.642.3253.0	25.642.0253.0
	100	11.90	7.00	3			25.642.3353.0	25.642.0353.0
	50	15.40	10.50	4			25.642.3453.0	25.642.0453.0
	50	18.90	14.00	5			25.642.3553.0	25.642.0553.0
	50	22.40	17.50	6			25.642.3653.0	25.642.0653.0
	50	25.90	21.00	7			25.642.3753.0	25.642.0753.0
	50	29.40	24.50	8			25.642.3853.0	25.642.0853.0
	50	32.90	28.00	9			25.642.3953.0	25.642.0953.0
	50	36.40	31.50	10			25.642.4053.0	25.642.1053.0
	50	39.90	35.00	11			25.642.4153.0	25.642.1153.0
	50	43.40	38.50	12			25.642.4253.0	25.642.1253.0
		46.90	42.00	13			25.642.4353.0	25.642.1353.0
		50.40	45.50	14			25.642.4453.0	25.642.1453.0
		53.90	49.00	15			25.642.4553.0	25.642.1553.0
		57.40	52.50	16			25.642.4653.0	25.642.1653.0
Accessories:								
DIN 5264 A 0.4 x 2.5	5				06.502.4300.0			

Pluggable PCB terminals,
rising cage clamp system, Pitch 3.81 mm

wiecon PCB

cable size
1.5 mm²

Rated cross section:
1.5 mm²

Rated current:
8 A

Wire range:
0.14 – 1.5 mm² single core/finely stranded

125 V/2.5 kV/3 – overvoltage category III
250 V/2.5 kV/2 – overvoltage category II
*690 V/2.5 kV/1 – overvoltage category I

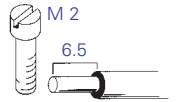
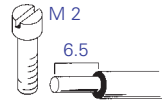
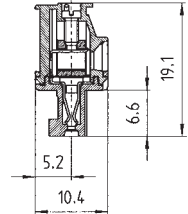
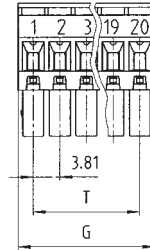
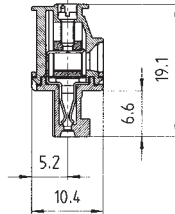
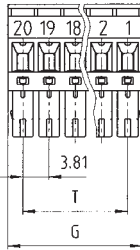

* max. 600V for non earthed systems or expected overvoltage
≤ 3 kV for L ≥ 2.00 mm and ≤ 2.5 kV for 2.0 mm > L ≥ 1.5 mm

Type 8813 B/... VR

Connection at 90° to conductor

Type 8813 B/... VL

Connection at 90° to conductor

Rated voltages VDE 0110

UL Data

CSA Data

Approvals

No. 30 – 16 AWG

300 V

8 A

No. 22 – 14 AWG

300 V

5 A



No. 30 – 16 AWG

300 V

8 A

No. 22 – 14 AWG

300 V

5 A



Box Qty	GFL	G	T	Pole	Part No.	Part No.	Part No.	Part No.
Pitch 3.81 mm					unmarked	marked	unmarked	marked
100	18.01	8.41	3.81	2	25.622.3253.0	25.622.0253.0	25.624.3253.0	25.624.0253.0
100	21.82	12.22	7.62	3	25.622.3353.0	25.622.0353.0	25.624.3353.0	25.624.0353.0
50	25.63	16.03	11.43	4	25.622.3453.0	25.622.0453.0	25.624.3453.0	25.624.0453.0
50	29.44	19.84	15.24	5	25.622.3553.0	25.622.0553.0	25.624.3553.0	25.624.0553.0
50	33.25	23.65	19.05	6	25.622.3653.0	25.622.0653.0	25.624.3653.0	25.624.0653.0
50	37.06	27.46	22.86	7	25.622.3753.0	25.622.0753.0	25.624.3753.0	25.624.0753.0
50	40.87	31.27	26.67	8	25.622.3853.0	25.622.0853.0	25.624.3853.0	25.624.0853.0
50	44.68	35.08	30.48	9	25.622.3953.0	25.622.0953.0	25.624.3953.0	25.624.0953.0
50	48.49	38.89	34.29	10	25.622.4053.0	25.622.1053.0	25.624.4053.0	25.624.1053.0
50	52.30	42.70	38.10	11	25.622.4153.0	25.622.1153.0	25.624.4153.0	25.624.1153.0
50	56.11	46.51	41.91	12	25.622.4253.0	25.622.1253.0	25.624.4253.0	25.624.1253.0
50	59.92	50.32	45.72	13	25.622.4353.0	25.622.1353.0	25.624.4353.0	25.624.1353.0
50	63.73	54.13	49.53	14	25.622.4453.0	25.622.1453.0	25.624.4453.0	25.624.1453.0
50	67.54	57.94	53.34	15	25.622.4553.0	25.622.1553.0	25.624.4553.0	25.624.1553.0
50	71.35	61.75	57.15	16	25.622.4653.0	25.622.1653.0	25.624.4653.0	25.624.1653.0

wiecon

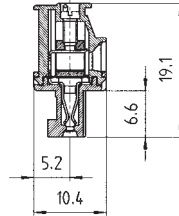
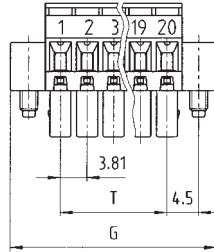
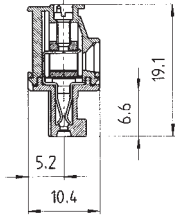
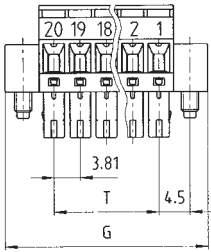

with screw flange

Type 8813 B/... VR F

Connection at 90° to conductor

No. 30 – 16 AWG

300 V

8 A

No. 22 – 14 AWG

300 V

5 A

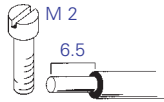

with screw flange

Type 8813 B/... VL F

Connection at 90° to conductor

No. 30 – 16 AWG

300 V

8 A

No. 22 – 14 AWG

300 V

5 A

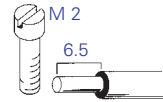

Part No.	Part No.	Part No.	Part No.	
unmarked	marked	unmarked	marked	
25.623.3253.0	25.623.0253.0	25.625.3253.0	25.625.0253.0	
25.623.3353.0	25.623.0353.0	25.625.3353.0	25.625.0353.0	
25.623.3453.0	25.623.0453.0	25.625.3453.0	25.625.0453.0	
25.623.3553.0	25.623.0553.0	25.625.3553.0	25.625.0553.0	
25.623.3653.0	25.623.0653.0	25.625.3653.0	25.625.0653.0	
25.623.3753.0	25.623.0753.0	25.625.3753.0	25.625.0753.0	
25.623.3853.0	25.623.0853.0	25.625.3853.0	25.625.0853.0	
25.623.3953.0	25.623.0953.0	25.625.3953.0	25.625.0953.0	
25.623.4053.0	25.623.1053.0	25.625.4053.0	25.625.1053.0	
25.623.4153.0	25.623.1153.0	25.625.4153.0	25.625.1153.0	
25.623.4253.0	25.623.1253.0	25.625.4253.0	25.625.1253.0	
25.623.4353.0	25.623.1353.0	25.625.4353.0	25.625.1353.0	
25.623.4453.0	25.623.1453.0	25.625.4453.0	25.625.1453.0	
25.623.4553.0	25.623.1553.0	25.625.4553.0	25.625.1553.0	
25.623.4653.0	25.640.1653.0	25.625.4653.0	25.625.1653.0	

PCB headers, pitch 3.50/3.81 mm

wiecon PCB

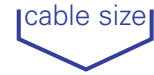

1.5 mm²

Rated current:
8 A

- 125 V/2.5 kV/3 – overvoltage category III
- 250 V/2.5 kV/2 – overvoltage category II
- * 690 V/2.5 kV/1 – overvoltage category I

Approvals for type 8513 have been applied for

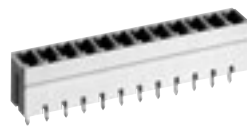
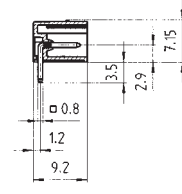
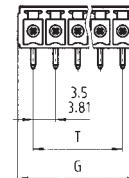
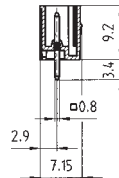
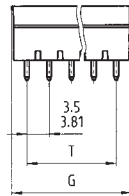

Solder pin 0.8 x 0.8 mm
Bore hole Ø 1.2 mm

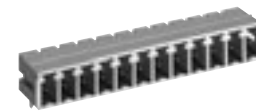

Solder pin 0.8 x 0.8 mm
Bore hole Ø 1.2 mm

Type 8513 S/... G, 8813 S/... G

Connection vertical to PCB

Type 8513 S/... W, 8813 S/... W

Connection horizontal to PCB

Rated voltages VDE 0110

UL Data

CSA Data

Approvals

300 V 8 A
300 V 5 A

300 V 8 A
300 V 5 A



Box Qty	GFL	G	T	Pole	Part No.	Part No.	Part No.	Part No.
Pitch 3.50 mm					unmarked		unmarked	
100	17.40	8.40	3.50	2	25.646.0253.0		25.647.0253.0	
100	20.90	11.90	7.00	3	25.646.0353.0		25.647.0353.0	
50	24.40	15.40	10.50	4	25.646.0453.0		25.647.0453.0	
50	27.90	18.90	14.00	5	25.646.0553.0		25.647.0553.0	
50	31.40	22.40	17.50	6	25.646.0653.0		25.647.0653.0	
50	34.90	25.90	21.00	7	25.646.0753.0		25.647.0753.0	
50	38.40	29.40	24.50	8	25.646.0853.0		25.647.0853.0	
50	41.90	32.90	28.00	9	25.646.0953.0		25.647.0953.0	
50	45.40	36.40	31.50	10	25.646.1053.0		25.647.1053.0	
50	48.90	39.90	35.00	11	25.646.1153.0		25.647.1153.0	
50	52.40	43.40	38.50	12	25.646.1253.0		25.647.1253.0	
50	55.90	46.90	42.00	13	25.646.1353.0		25.647.1353.0	
50	59.40	50.40	45.50	14	25.646.1453.0		25.647.1453.0	
50	62.90	53.90	49.00	15	25.646.1553.0		25.647.1553.0	
50	66.40	57.40	52.50	16	25.646.1653.0		25.647.1653.0	
Pitch 3.81 mm					unmarked		unmarked	
100	18.01	9.01	3.81	2	25.626.0253.0		25.627.0253.0	
100	21.82	12.82	7.62	3	25.626.0353.0		25.627.0353.0	
50	25.63	16.63	11.43	4	25.626.0453.0		25.627.0453.0	
50	29.44	20.44	15.24	5	25.626.0553.0		25.627.0553.0	
50	33.25	24.25	19.05	6	25.626.0653.0		25.627.0653.0	
50	37.06	28.06	22.86	7	25.626.0753.0		25.627.0753.0	
50	40.87	31.87	26.67	8	25.626.0853.0		25.627.0853.0	
50	44.68	35.68	30.48	9	25.626.0953.0		25.627.0953.0	
50	48.49	39.49	34.29	10	25.626.1053.0		25.627.1053.0	
50	52.30	43.30	38.10	11	25.626.1153.0		25.627.1153.0	
50	56.11	47.11	41.91	12	25.626.1253.0		25.627.1253.0	
50	59.92	50.92	45.72	13	25.626.1353.0		25.627.1353.0	
50	63.73	54.73	49.53	14	25.626.1453.0		25.627.1453.0	
50	67.54	58.54	53.34	15	25.626.1553.0		25.627.1553.0	
50	71.35	62.35	57.15	16	25.626.1653.0		25.627.1653.0	
Accessories:								
Coding part (branch)	100				05.561.0053.0		05.561.0053.0	
When using coding parts, the coding fins on the terminal connector should be removed								

wiecon

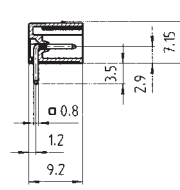
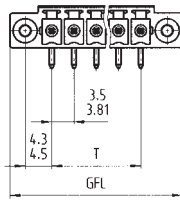
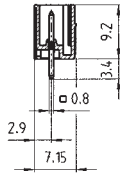
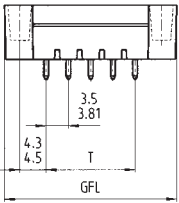

with screw flange

Solder pin 0.8 x 0.8 mm
Bore hole Ø 1.2 mm



with screw flange

Solder pin 0.8 x 0.8 mm
Bore hole Ø 1.2 mm

Type 8513 S/... GF, 8813 S/... GF

Connection vertical to PCB

300 V 8 A
300 V 5 A



Type 8513 S/... WF, 8813 S/... WF

Connection horizontal to PCB

300 V 8 A
300 V 5 A



Part No.	Part No.	Part No.	Part No.
unmarked		unmarked	
25.646.3253.0		25.647.3253.0	
25.646.3353.0		25.647.3353.0	
25.646.3453.0		25.647.3453.0	
25.646.3553.0		25.647.3553.0	
25.646.3653.0		25.647.3653.0	
25.646.3753.0		25.647.3753.0	
25.646.3853.0		25.647.3853.0	
25.646.3953.0		25.647.3953.0	
25.646.4053.0		25.647.4053.0	
25.646.4153.0		25.647.4153.0	
25.646.4253.0		25.647.4253.0	
25.646.4353.0		25.647.4353.0	
25.646.4453.0		25.647.4453.0	
25.646.4553.0		25.647.4553.0	
25.646.4653.0		25.647.4653.0	
unmarked		unmarked	
25.626.3253.0		25.627.3253.0	
25.626.3353.0		25.627.3353.0	
25.626.3453.0		25.627.3453.0	
25.626.3553.0		25.627.3553.0	
25.626.3653.0		25.627.3653.0	
25.626.3753.0		25.627.3753.0	
25.626.3853.0		25.627.3853.0	
25.626.3953.0		25.627.3953.0	
25.626.4053.0		25.627.4053.0	
25.626.4153.0		25.627.4153.0	
25.626.4253.0		25.627.4253.0	
25.626.4353.0		25.627.4353.0	
25.626.4453.0		25.627.4453.0	
25.626.4553.0		25.627.4553.0	
25.626.4653.0		25.627.4653.0	
05.561.0053.0		05.561.0053.0	

Pluggable PCB terminals, rising cage clamp, pitch 5.00/5.08 mm

wiecon PCB

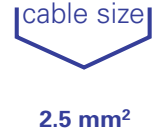

Rated cross section:
2.5 mm²

Rated current:
12 A

Wire range:
0.14 – 2.5 mm² single core/finely stranded

250 V/4 kV/3 – overvoltage category III
400 V/4 kV/2 – overvoltage category II
1000 V/4 kV/1 – overvoltage category I

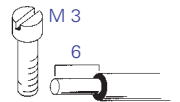
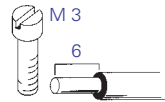
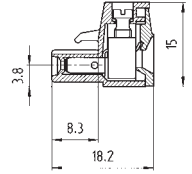
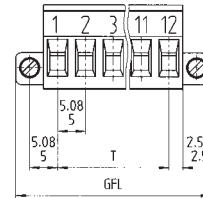
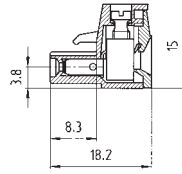
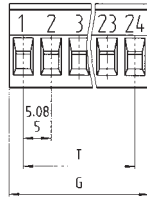

Type 8113 B/... 8213 B/...
Connection in line with conductor

Type 8113 B/... F, 8213 B/... F
Connection in line with conductor

Rated voltages VDE 0110
UL Data
CSA Data
Approvals

No. 22 – 12 AWG 300 V 15 A
No. 22 – 12 AWG 300 V 15 A

No. 22 – 12 AWG 300 V 15 A
No. 22 – 12 AWG 300 V 15 A

Box Qty	GFL	G	T	Pole	Part No.	Part No.	Part No.	Part No.	
Pitch 5.00 mm					Type 8113	unmarked	marked	unmarked	marked
100	20	10	5	2	25.320.3253.0	25.320.0253.0	25.322.3253.0	25.322.0253.0	
100	25	15	10	3	25.320.3353.0	25.320.0353.0	25.322.3353.0	25.322.0353.0	
50	30	20	15	4	25.320.3453.0	25.320.0453.0	25.322.3453.0	25.322.0453.0	
50	35	25	20	5	25.320.3553.0	25.320.0553.0	25.322.3553.0	25.322.0553.0	
50	40	30	25	6	25.320.3653.0	25.320.0653.0	25.322.3653.0	25.322.0653.0	
50	45	35	30	7	25.320.3753.0	25.320.0753.0	25.322.3753.0	25.322.0753.0	
50	50	40	35	8	25.320.3853.0	25.320.0853.0	25.322.3853.0	25.322.0853.0	
50	55	45	40	9	25.320.3953.0	25.320.0953.0	25.322.3953.0	25.322.0953.0	
50	60	50	45	10	25.320.4053.0	25.320.1053.0	25.322.4053.0	25.322.1053.0	
50	65	55	50	11	25.320.4153.0	25.320.1153.0	25.322.4153.0	25.322.1153.0	
50	70	60	55	12	25.320.4253.0	25.320.1253.0	25.322.4253.0	25.322.1253.0	
50	75	65	60	13	25.320.4353.0	25.320.1353.0	25.322.4353.0	25.322.1353.0	
50	80	70	65	14	25.320.4453.0	25.320.1453.0	25.322.4453.0	25.322.1453.0	
50	85	75	70	15	25.320.4553.0	25.320.1553.0	25.322.4553.0	25.322.1553.0	
50	90	80	75	16	25.320.4653.0	25.320.1653.0	25.322.4653.0	25.322.1653.0	
					17 to 24 pole on request		17 to 22 pole on request		
Pitch 5.08 mm					Type 8213	unmarked	marked	unmarked	marked
100	20.32	10.16	5.08	2	25.340.3253.0	25.340.0253.0	25.323.3253.0	25.323.0253.0	
100	25.40	15.24	10.16	3	25.340.3353.0	25.340.0353.0	25.323.3353.0	25.323.0353.0	
50	30.48	20.32	15.24	4	25.340.3453.0	25.340.0453.0	25.323.3453.0	25.323.0453.0	
50	35.56	25.40	20.32	5	25.340.3553.0	25.340.0553.0	25.323.3553.0	25.323.0553.0	
50	40.64	30.48	25.40	6	25.340.3653.0	25.340.0653.0	25.323.3653.0	25.323.0653.0	
50	45.72	35.56	30.48	7	25.340.3753.0	25.340.0753.0	25.323.3753.0	25.323.0753.0	
50	50.80	40.64	35.56	8	25.340.3853.0	25.340.0853.0	25.323.3853.0	25.323.0853.0	
50	55.88	45.72	40.64	9	25.340.3953.0	25.340.0953.0	25.323.3953.0	25.323.0953.0	
50	60.96	50.80	45.72	10	25.340.4053.0	25.340.1053.0	25.323.4053.0	25.323.1053.0	
50	66.04	55.88	50.80	11	25.340.4153.0	25.340.1153.0	25.323.4153.0	25.323.1153.0	
50	71.12	60.96	55.88	12	25.340.4253.0	25.340.1253.0	25.323.4253.0	25.323.1253.0	
50	76.20	66.04	60.96	13	25.340.4353.0	25.340.1353.0	25.323.4353.0	25.323.1353.0	
50	81.28	71.12	66.04	14	25.340.4453.0	25.340.1453.0	25.323.4453.0	25.323.1453.0	
50	86.36	76.20	71.12	15	25.340.4553.0	25.340.1553.0	25.323.4553.0	25.323.1553.0	
50	91.44	81.28	76.20	16	25.340.4653.0	25.340.1653.0	25.323.4653.0	25.323.1653.0	
							17 to 22 pole on request		
Accessories:									
Coding part (branch)	100				05.561.9153.0	05.561.9153.0			

Pluggable PCB terminals, rising cage clamp system, Pitch 7.50/7.62 mm

wiecon PCB



Rated cross section:
2.5 mm²

Rated current:
12 A

Wire range:
0.14 – 2.5 mm² single core/finely stranded

400 V/4 kV/3 – overvoltage category III
690 V/4 kV/2 – overvoltage category II
1000 V/4 kV/1 – overvoltage category I

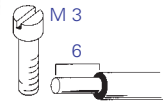
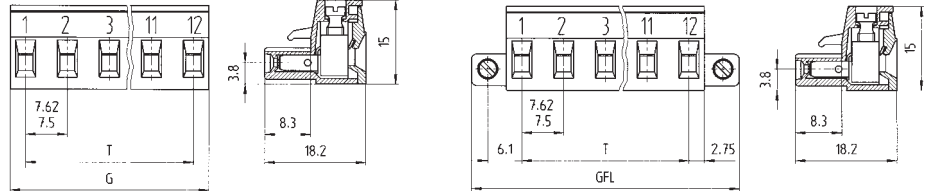

Type 8313 B/..., 8413 B/...

Connection in line with conductor

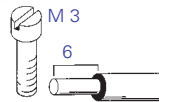

with screw flange

Type 8313 B/... F, 8413 B/... F

Connection in line with conductor

Rated voltages VDE 0110

UL Data

CSA Data

Approvals

No. 22 – 12 AWG

300 V

15 A

No. 22 – 12 AWG

300 V

15 A



No. 22 – 12 AWG

300 V

15 A

No. 22 – 12 AWG

300 V

15 A



Box Qty	GFL	G	T	Pole	Part No.	Part No.	Part No.	Part No.	
Pitch 7.50 mm				Type 8313		unmarked	marked	unmarked	marked
100	25.54	13.00	7.50	2	25.360.3253.0	25.360.0253.0	25.324.2253.0	25.324.0253.0	
100	33.04	20.50	15.00	3	25.360.3353.0	25.360.0353.0	25.324.2353.0	25.324.0353.0	
50	40.54	28.00	22.50	4	25.360.3453.0	25.360.0453.0	25.324.2453.0	25.324.0453.0	
50	48.04	35.50	30.00	5	25.360.3553.0	25.360.0553.0	25.324.2553.0	25.324.0553.0	
50	55.54	43.00	37.50	6	25.360.3653.0	25.360.0653.0	25.324.2653.0	25.324.0653.0	
50	63.04	50.50	45.00	7	25.360.3753.0	25.360.0753.0	25.324.2753.0	25.324.0753.0	
50	70.54	58.00	52.50	8	25.360.3853.0	25.360.0853.0	25.324.2853.0	25.324.0853.0	
50	78.04	65.50	60.00	9	25.360.3953.0	25.360.0953.0	25.324.2953.0	25.324.0953.0	
50	85.54	73.00	67.50	10	25.360.4053.0	25.360.1053.0	25.324.3053.0	25.324.1053.0	
50	93.04	80.50	75.00	11	25.360.4153.0	25.360.1153.0	25.324.3153.0	25.324.1153.0	
50	100.54	88.00	82.50	12	25.360.4253.0	25.360.1253.0	25.324.3253.0	25.324.1253.0	
Pitch 7.62 mm				Type 8413		unmarked	marked	unmarked	marked
100	25.66	13.12	7.62	2	25.380.3253.0	25.380.0253.0	25.324.6253.0	25.324.4253.0	
100	33.28	20.74	15.24	3	25.380.3353.0	25.380.0353.0	25.324.6353.0	25.324.4353.0	
50	40.90	28.36	22.86	4	25.380.3453.0	25.380.0453.0	25.324.6453.0	25.324.4453.0	
50	48.52	35.98	30.48	5	25.380.3553.0	25.380.0553.0	25.324.6553.0	25.324.4553.0	
50	56.14	43.60	38.10	6	25.380.3653.0	25.380.0653.0	25.324.6653.0	25.324.4653.0	
50	63.76	51.22	45.72	7	25.380.3753.0	25.380.0753.0	25.324.6753.0	25.324.4753.0	
50	71.38	58.84	53.34	8	25.380.3853.0	25.380.0853.0	25.324.6853.0	25.324.4853.0	
50	79.00	66.46	60.96	9	25.380.3953.0	25.380.0953.0	25.324.6953.0	25.324.4953.0	
50	86.62	74.08	68.58	10	25.380.4053.0	25.380.1053.0	25.324.7053.0	25.324.5053.0	
50	94.24	81.70	76.20	11	25.380.4153.0	25.380.1153.0	25.324.7153.0	25.324.5153.0	
50	101.86	89.32	83.82	12	25.380.4253.0	25.380.1253.0	25.324.7253.0	25.324.5253.0	
Accessories:									
Coding part (branch)	100					05.561.9153.0	05.561.9153.0		

Pluggable PCB terminals, rising cage clamp system, Pitch 5.00/5.08 mm

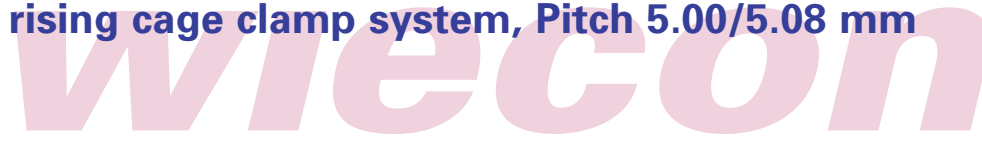

cable size
2.5 mm²

Rated cross section:
2.5 mm²

Rated current:
12 A

Wire range:
0.14 – 2.5 mm² single core/finely stranded

250 V/4 kV/3 – overvoltage category III
400 V/4 kV/2 – overvoltage category II
1000 V/4 kV/1 – overvoltage category I

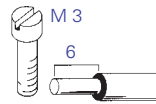
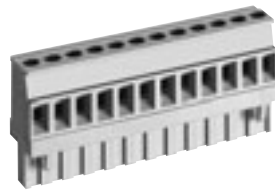
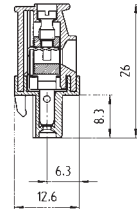
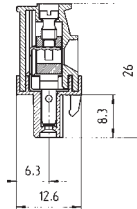
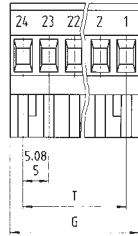

Type 8113 B/... VR, 8213 B/... VR

Connection 90° to conductor

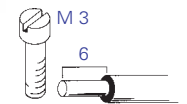

Type 8113 B/... VL, 8213 B/... VL

Connection 90° to conductor

Rated voltages VDE 0110

UL Data

CSA Data

Approvals

No. 22 – 12 AWG

300 V

15 A

No. 22 – 12 AWG

300 V

15 A



No. 22 – 12 AWG

300 V

15 A

No. 22 – 12 AWG

300 V

15 A



Box Qty	G	T	Pole	Part No.	Part No.	Part No.	Part No.
Pitch 5.00 mm				Type 8113		Type 8113	
				unmarked	marked	unmarked	marked
100	10	5	2	25.325.3253.0	25.325.0253.0	25.326.3253.0	25.326.0253.0
100	15	10	3	25.325.3353.0	25.325.0353.0	25.326.3353.0	25.326.0353.0
50	20	15	4	25.325.3453.0	25.325.0453.0	25.326.3453.0	25.326.0453.0
50	25	20	5	25.325.3553.0	25.325.0553.0	25.326.3553.0	25.326.0553.0
50	30	25	6	25.325.3653.0	25.325.0653.0	25.326.3653.0	25.326.0653.0
50	35	30	7	25.325.3753.0	25.325.0753.0	25.326.3753.0	25.326.0753.0
50	40	35	8	25.325.3853.0	25.325.0853.0	25.326.3853.0	25.326.0853.0
50	45	40	9	25.325.3953.0	25.325.0953.0	25.326.3953.0	25.326.0953.0
50	50	45	10	25.325.4053.0	25.325.1053.0	25.326.4053.0	25.326.1053.0
50	55	50	11	25.325.4153.0	25.325.1153.0	25.326.4153.0	25.326.1153.0
50	60	55	12	25.325.4253.0	25.325.1253.0	25.326.4253.0	25.326.1253.0
50	65	60	13	25.325.4353.0	25.325.1353.0	25.326.4353.0	25.326.1353.0
50	70	65	14	25.325.4453.0	25.325.1453.0	25.326.4453.0	25.326.1453.0
50	75	70	15	25.325.4553.0	25.325.1553.0	25.326.4553.0	25.326.1553.0
50	80	75	16	25.325.4653.0	25.325.1653.0	25.326.4653.0	25.326.1653.0
17 to 24 pole on request							
Pitch 5.08 mm				Type 8213		Type 8213	
				unmarked	marked	unmarked	marked
100	10.16	5.08	2	25.345.3253.0	25.345.0253.0	25.346.3253.0	25.346.0253.0
100	15.24	10.16	3	25.345.3353.0	25.345.0353.0	25.346.3353.0	25.346.0353.0
50	20.32	15.24	4	25.345.3453.0	25.345.0453.0	25.346.3453.0	25.346.0453.0
50	25.40	20.32	5	25.345.3553.0	25.345.0553.0	25.346.3553.0	25.346.0553.0
50	30.48	25.40	6	25.345.3653.0	25.345.0653.0	25.346.3653.0	25.346.0653.0
50	35.56	30.48	7	25.345.3753.0	25.345.0753.0	25.346.3753.0	25.346.0753.0
50	40.64	35.56	8	25.345.3853.0	25.345.0853.0	25.346.3853.0	25.346.0853.0
50	45.72	40.64	9	25.345.3953.0	25.345.0953.0	25.346.3953.0	25.346.0953.0
50	50.80	45.72	10	25.345.4053.0	25.345.1053.0	25.346.4053.0	25.346.1053.0
50	55.88	50.80	11	25.345.4153.0	25.345.1153.0	25.346.4153.0	25.346.1153.0
50	60.96	55.88	12	25.345.4253.0	25.345.1253.0	25.346.4253.0	25.346.1253.0
50	66.04	60.96	13	25.345.4353.0	25.345.1353.0	25.346.4353.0	25.346.1353.0
50	71.12	66.04	14	25.345.4453.0	25.345.1453.0	25.346.4453.0	25.346.1453.0
50	76.20	71.12	15	25.345.4553.0	25.345.1553.0	25.346.4553.0	25.346.1553.0
50	81.28	76.20	16	25.345.4653.0	25.345.1653.0	25.346.4653.0	25.346.1653.0
17 to 24 pole on request							
Accessories:							
Coding part (branch)	100			05.561.9153.0		05.561.9153.0	

Pluggable PCB terminals, rising cage clamp system, pitch 7.62 mm

wiecon PCB

cable size

2.5 mm²

Rated cross section:
2.5 mm²

Rated current:
12 A

Wire range:
0.14 – 2.5 mm² single core/finely stranded

400 V/4 kV/3 – overvoltage category III
690 V/4 kV/2 – overvoltage category II
1000 V/4 kV/1 – overvoltage category I

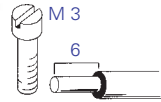
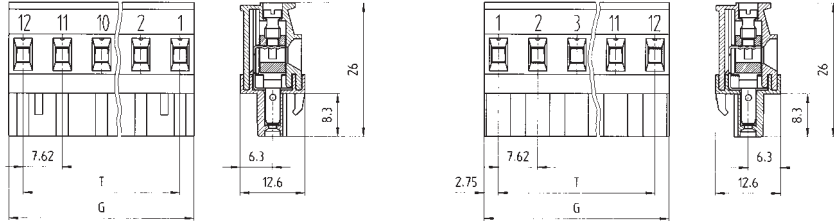

Type 8413 B/... VR

Connection 90° to conductor

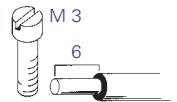

Type 8413 B/... VL

Connection 90° to conductor

Rated voltages VDE 0110

UL Data

CSA Data

Approvals

No. 22 – 12 AWG

300 V

15 A

No. 22 – 12 AWG

300 V

15 A



No. 22 – 12 AWG

300 V

15 A

No. 22 – 14 AWG

300 V

15 A



Box Qty	G	T	Pole	Part No.	Part No.	Part No.	Part No.
Pitch 7.62 mm				Type 8413		Type 8413	
				unmarked	marked	unmarked	marked
100	13.12	7.62	2	25.385.2253.0	25.385.0253.0	25.386.2253.0	25.386.0253.0
100	20.74	15.24	3	25.385.2353.0	25.385.0353.0	25.386.2353.0	25.386.0353.0
50	28.36	22.86	4	25.385.2453.0	25.385.0453.0	25.386.2453.0	25.386.0453.0
50	35.98	30.48	5	25.385.2553.0	25.385.0553.0	25.386.2553.0	25.386.0553.0
50	43.60	38.10	6	25.385.2653.0	25.385.0653.0	25.386.2653.0	25.386.0653.0
50	51.22	45.72	7	25.385.2753.0	25.385.0753.0	25.386.2753.0	25.386.0753.0
50	58.84	53.34	8	25.385.2853.0	25.385.0853.0	25.386.2853.0	25.386.0853.0
50	66.46	60.96	9	25.385.2953.0	25.385.0953.0	25.386.2953.0	25.386.0953.0
50	74.08	68.58	10	25.385.3053.0	25.385.1053.0	25.386.3053.0	25.386.1053.0
50	81.70	76.20	11	25.385.3153.0	25.385.1153.0	25.386.3153.0	25.386.1153.0
50	89.32	83.82	12	25.385.3253.0	25.385.1253.0	25.386.3253.0	25.386.1253.0
Accessories:							
Coding part (branch)	100			05.561.9153.0		05.561.9153.0	

Crimp connection

wiecon

Rated cross section:
2.5 mm²

Rated current:
10 A when using a 1.0 mm² Leiter

12 A when using a 2.5 mm² Leiter

Contact for wire range:
0.5 – 1.0 mm² finely stranded
(Diameter of insulation 1.4 – 2.3 mm)

Wire range:
1.5 – 2.5 mm² finely stranded
(Diameter of insulation 1.4 – 3.1 mm)

250 V/4 kV/3 – overvoltage category III
400 V/4 kV/2 – overvoltage category II
1000 V/4 kV/1 – overvoltage category I

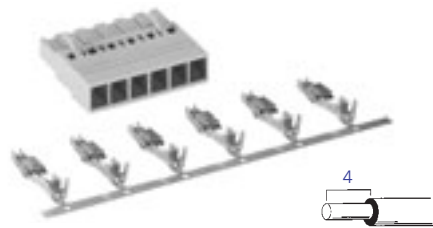
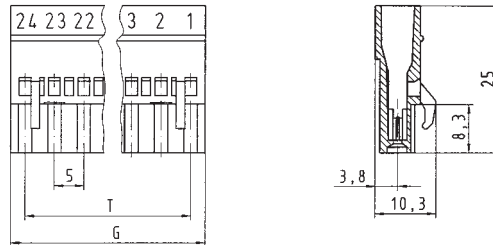

Type 8113 BK

Rated voltages VDE 0110

UL Data

CSA Data

Approvals



	Box Qty	G	T	Pole	Part No.	Part No.	Part No.	Part No.
Pitch 5.00 mm					unmarked	marked		
	100	10	5	2	01.060.3253.0	01.060.0253.0		
	100	15	10	3	01.060.3353.0	01.060.0353.0		
	50	20	15	4	01.060.3453.0	01.060.0453.0		
	50	25	20	5	01.060.3553.0	01.060.0553.0		
	50	30	25	6	01.060.3653.0	01.060.0653.0		
	50	35	30	7	01.060.3753.0	01.060.0753.0		
	50	40	35	8	01.060.3853.0	01.060.0853.0		
	50	45	40	9	01.060.3953.0	01.060.0953.0		
	50	50	45	10	01.060.4053.0	01.060.1053.0		
	50	55	50	11	01.060.4153.0	01.060.1153.0		
	50	60	55	12	01.060.4253.0	01.060.1253.0		
	50	65	60	13	01.060.4353.0	01.060.1353.0		
	50	70	65	14	01.060.4453.0	01.060.1453.0		
	50	75	70	15	01.060.4553.0	01.060.1553.0		
	50	80	75	16	01.060.4653.0	01.060.1653.0		
					17 to 24 pole on request			
Accessories:								
Crimp contacts								
Single contacts	500	0.5 – 1.0 mm ²			02.125.1629.0			
Single contacts	500	1.5 – 2.5 mm ²			02.125.1729.0			
Strip	4000	0.5 – 1.0 mm ²			02.125.1600.0			
Strip	3500	1.5 – 2.5 mm ²			02.125.1700.0			
Crimping tool:								
Crimping tool					95.101.0800.0			
Crimp dies					05.502.2500.0			

Pluggable PCB terminals – spring clamp system pitch 5.00/5.08 mm

wiecon PCB

Rated cross section*:
2.5 mm²

Rated current:
12 A

Wire range:
0.14 – 2.5 mm² single core/finely stranded

250 V/4 kV/3 – overvoltage category III
400 V/4 kV/2 – overvoltage category II
1000 V/4 kV/1 – overvoltage category I

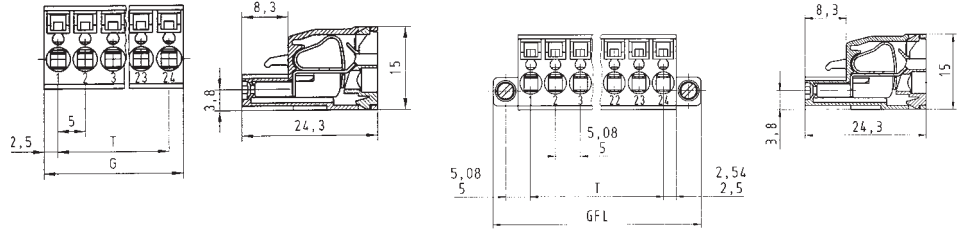

Type 8113/8213 BFK



Type 8113/8213 BFK .../F

* When using ferrules for wire range 2.5 mm, only ferrules with part number 2.5 mm 05.596.6127.0 should be used.

Rated voltages VDE 0110
UL Data
CSA Data
Approvals

No. 22 – 12 AWG

300 V

12 A

No. 22 – 12 AWG

300 V

12 A



Box Qty	GFL	G	T	Pole	Part No.	Part No.	Part No.	Part No.
Pitch 5.00 mm					unmarked	marked	unmarked	marked
100	22.54	10	5	2	25.820.3253.0	25.820.0253.0	25.821.3253.0	25.821.0253.0
100	27.54	15	10	3	25.820.3353.0	25.820.0353.0	25.821.3353.0	25.821.0353.0
50	32.54	20	15	4	25.820.3453.0	25.820.0453.0	25.821.3453.0	25.821.0453.0
50	37.54	25	20	5	25.820.3553.0	25.820.0553.0	25.821.3553.0	25.821.0553.0
50	42.54	30	25	6	25.820.3653.0	25.820.0653.0	25.821.3653.0	25.821.0653.0
50	47.54	35	30	7	25.820.3753.0	25.820.0753.0	25.821.3753.0	25.821.0753.0
50	52.54	40	35	8	25.820.3853.0	25.820.0853.0	25.821.3853.0	25.821.0853.0
50	57.54	45	40	9	25.820.3953.0	25.820.0953.0	25.821.3953.0	25.821.0953.0
50	62.54	50	45	10	25.820.4053.0	25.820.1053.0	25.821.4053.0	25.821.1053.0
50	67.54	55	50	11	25.820.4153.0	25.820.1153.0	25.821.4153.0	25.821.1153.0
50	72.54	60	55	12	25.820.4253.0	25.820.1253.0	25.821.4253.0	25.821.1253.0
50	77.54	65	60	13	25.820.4353.0	25.820.1353.0	25.821.4353.0	25.821.1353.0
50	82.54	70	65	14	25.820.4453.0	25.820.1453.0	25.821.4453.0	25.821.1453.0
50	87.54	75	70	15	25.820.4553.0	25.820.1553.0	25.821.4553.0	25.821.1553.0
50	92.54	80	75	16	25.820.4653.0	25.820.1653.0	25.821.4653.0	25.821.1653.0
					17 to 24 pole on request		17 to 24 pole on request	
Pitch 5.08 mm					unmarked	marked	unmarked	marked
100	22.70	10.16	5.08	2	25.840.3253.0	25.840.0253.0	25.841.3253.0	25.841.0253.0
100	27.78	15.24	10.16	3	25.840.3353.0	25.840.0353.0	25.841.3353.0	25.841.0353.0
50	32.86	20.32	15.24	4	25.840.3453.0	25.840.0453.0	25.841.3453.0	25.841.0453.0
50	37.94	25.40	20.32	5	25.840.3553.0	25.840.0553.0	25.841.3553.0	25.841.0553.0
50	43.02	30.48	25.40	6	25.840.3653.0	25.840.0653.0	25.841.3653.0	25.841.0653.0
50	48.10	35.56	30.48	7	25.840.3753.0	25.840.0753.0	25.841.3753.0	25.841.0753.0
50	53.18	40.64	35.56	8	25.840.3853.0	25.840.0853.0	25.841.3853.0	25.841.0853.0
50	58.26	45.72	40.64	9	25.840.3953.0	25.840.0953.0	25.841.3953.0	25.841.0953.0
50	63.34	50.80	45.72	10	25.840.4053.0	25.840.1053.0	25.841.4053.0	25.841.1053.0
50	68.42	55.88	50.80	11	25.840.4153.0	25.840.1153.0	25.841.4153.0	25.841.1153.0
50	73.50	60.96	55.88	12	25.840.4253.0	25.840.1253.0	25.841.4253.0	25.841.1253.0
50	78.58	66.04	60.96	13	25.840.4353.0	25.840.1353.0	25.841.4353.0	25.841.1353.0
50	83.66	71.12	66.04	14	25.840.4453.0	25.840.1453.0	25.841.4453.0	25.841.1453.0
50	88.74	76.20	71.12	15	25.840.4553.0	25.840.1553.0	25.841.4553.0	25.841.1553.0
50	93.82	81.28	76.20	16	25.840.4653.0	25.840.1653.0	25.841.4653.0	25.841.1653.0
					17 to 24 pole on request		17 to 24 pole on request	

Pluggable PCB terminal - spring clamp system pitch 5.08 mm

wiecon

cable size

2.5 mm²

Rated cross section*:
2.5 mm²

Rated current:
12 A

Wire range:
0.14 – 2.5 mm² single core/finely stranded

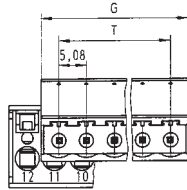

250 V/4 kV/3 – overvoltage category III
400 V/4 kV/2 – overvoltage category II
1000 V/4 kV/1 – overvoltage category I



* When using ferrules for wire range 2.5 mm, only ferrules with part number 2.5 mm 05.596.6127.0 should be used.

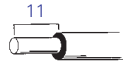

Type 8213 SUFK

Rated voltages VDE 0110
UL Data
CSA Data
Approvals in preparation

No. 22 – 12 AWG 300 V 12 A
No. 22 – 12 AWG 300 V 12 A



	Box Qty	G	T	Pole	Part No.	Part No.	
Pitch 5.08 mm					unmarked	marked	
	100	10.16	5.08	2	25.857.3253.0	25.857.0253.0	
	100	15.24	10.16	3	25.857.3353.0	25.857.0353.0	
	50	20.32	15.24	4	25.857.3453.0	25.857.0453.0	
	50	25.40	20.32	5	25.857.3553.0	25.857.0553.0	
	50	30.48	25.40	6	25.857.3653.0	25.857.0653.0	
	50	35.56	30.48	7	25.857.3753.0	25.857.0753.0	
	50	40.64	35.56	8	25.857.3853.0	25.857.0853.0	
	50	45.72	40.64	9	25.857.3953.0	25.857.0953.0	
	50	50.80	45.72	10	25.857.4053.0	25.857.1053.0	
	50	55.88	50.80	11	25.857.4153.0	25.857.1153.0	
	50	60.96	55.88	12	25.857.4253.0	25.857.1253.0	
	50	66.04	60.96	13	25.857.4353.0	25.857.1353.0	
	50	71.12	66.04	14	25.857.4453.0	25.857.1453.0	
	50	76.20	71.12	15	25.857.4553.0	25.857.1553.0	
	50	81.28	76.20	16	25.857.4653.0	25.857.1653.0	
	17 to 24 pole on request						
Accessories:							
Coding part (branch)	100				05.561.9153.0		
Screwdriver DIN 5264 A 0.6 x 3.5	5				06.502.4000.0		

Pluggable PCB terminal - spring clamp system pitch 7.62 mm

wiecon PCB

Rated cross section*:
2.5 mm²

Rated current:
12 A

Wire range:
0.14 – 2.5 mm² single core/finely stranded

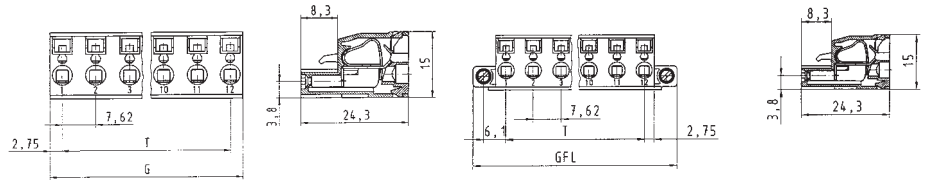

400 V/6 kV/3 – overvoltage category III
** 690 V/6 kV/2 – overvoltage category II
1000 V/6 kV/1 – overvoltage category I

* When using ferrules for wire range 2.5 mm, only ferrules with part number 05.596.6127.0 should be used.

** max. 600 V for non-earthed systems or expected overvoltage
≤ 3 kV for L ≥ 2.00 mm and ≤ 2.5 kV for 2.0 mm > L ≥ 1.5 mm



Type 8413 BFK

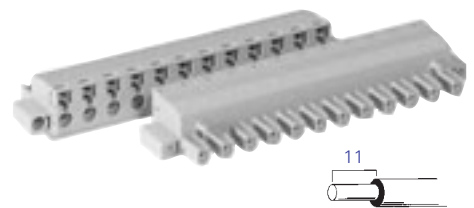

Type 8413 BFK/... F

VDE 0110
UL Data
CSA Data
Approvals

No. 22 – 12 AWG

300 V 12 A

No. 22 – 12 AWG

300 V 12 A

Box Qty	GFL	G	T	Pole	Part No.	Part No.	Part No.	Part No.
Pitch 7.62 mm					unmarked	marked	unmarked	marked
100	25.66	13.12	7.62	2	25.880.3253.0	25.880.0253.0	25.881.3253.0	25.881.0253.0
100	33.28	20.74	15.24	3	25.880.3353.0	25.880.0353.0	25.881.3353.0	25.881.0353.0
50	40.90	28.36	22.86	4	25.880.3453.0	25.880.0453.0	25.881.3453.0	25.881.0453.0
50	48.52	35.98	30.48	5	25.880.3553.0	25.880.0553.0	25.881.3553.0	25.881.0553.0
50	56.14	43.60	38.10	6	25.880.3653.0	25.880.0653.0	25.881.3653.0	25.881.0653.0
50	63.76	51.22	45.72	7	25.880.3753.0	25.880.0753.0	25.881.3753.0	25.881.0753.0
50	71.38	58.84	53.34	8	25.880.3853.0	25.880.0853.0	25.881.3853.0	25.881.0853.0
50	79.00	66.46	60.96	9	25.880.3953.0	25.880.0953.0	25.881.3953.0	25.881.0953.0
50	86.62	74.08	68.58	10	25.880.4053.0	25.880.1053.0	25.881.4053.0	25.881.1053.0
50	94.24	81.70	76.20	11	25.880.4153.0	25.880.1153.0	25.881.4153.0	25.881.1153.0
50	101.86	89.32	83.82	12	25.880.4253.0	25.880.1253.0	25.881.4253.0	25.881.1253.0

Pluggable PCB terminal, inverted header, solder version pitch 5.08 mm

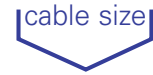

Rated current:
12 A

250 V/4 kV/3 – overvoltage category III
*690 V/4 kV/2 – overvoltage category II
1000 V/4 kV/1 – overvoltage category I

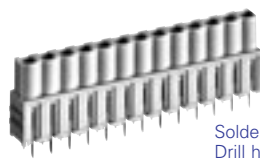
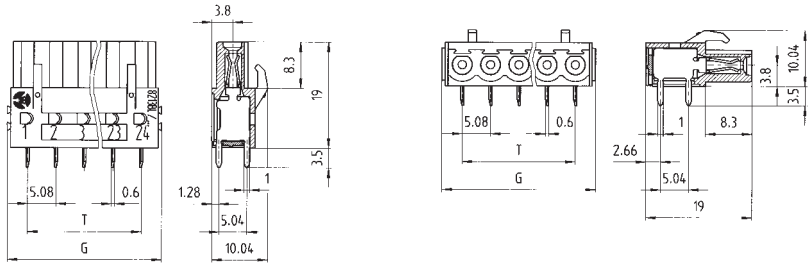

Solder pin 0.6 x 1 mm
Drill hole Ø 1.2 mm

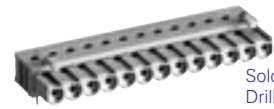

Solder pin 0.6 x 1 mm
Drill hole Ø 1.2 mm

* max. 600V for non earthed systems or expected overvoltage
≤ 3 kV for L ≥ 2.00 mm and ≤ 2.5 kV for 2.0 mm > L ≥ 1.5 mm

Type 8213 BL/... G

Connection vertical to PCB

Type 8213 BL/... W

Connection vertical to PCB

Rated voltages VDE 0110

UL Data

CSA Data

Approvals

300 V 15 A
300 V 15 A

300 V 15 A
300 V 15 A



Box Qty	G	T	Pole	Part No.	Part No.	Part No.	Part No.
				unmarked	marked	unmarked	marked
Pitch 5.08 mm							
100	12.36	5.08	2	25.342.3253.0	25.342.0253.0	25.343.3253.0	25.343.0253.0
100	17.44	10.16	3	25.342.3353.0	25.342.0353.0	25.343.3353.0	25.343.0353.0
50	22.52	15.24	4	25.342.3453.0	25.342.0453.0	25.343.3453.0	25.343.0453.0
50	27.60	20.32	5	25.342.3553.0	25.342.0553.0	25.343.3553.0	25.343.0553.0
50	32.68	25.40	6	25.342.3653.0	25.342.0653.0	25.343.3653.0	25.343.0653.0
50	37.76	30.48	7	25.342.3753.0	25.342.0753.0	25.343.3753.0	25.343.0753.0
50	42.84	35.56	8	25.342.3853.0	25.342.0853.0	25.343.3853.0	25.343.0853.0
50	47.92	40.64	9	25.342.3953.0	25.342.0953.0	25.343.3953.0	25.343.0953.0
50	53.00	45.72	10	25.342.4053.0	25.342.1053.0	25.343.4053.0	25.343.1053.0
50	58.08	50.80	11	25.342.4153.0	25.342.1153.0	25.343.4153.0	25.343.1153.0
50	63.16	55.88	12	25.342.4253.0	25.342.1253.0	25.343.4253.0	25.343.1253.0
50	68.24	60.96	13	25.342.4353.0	25.342.1353.0	25.343.4353.0	25.343.1353.0
50	73.32	66.04	14	25.342.4453.0	25.342.1453.0	25.343.4453.0	25.343.1453.0
50	78.40	71.12	15	25.342.4553.0	25.342.1553.0	25.343.4553.0	25.343.1553.0
50	83.48	76.20	16	25.342.4653.0	25.342.1653.0	25.343.4653.0	25.343.1653.0
17 to 24 pole on request							
Accessories:							
Coding part (branch)	100			05.561.9153.0		05.561.9153.0	
Mounting bracket	100			Z5.523.7853.0		Z5.523.7753.0	

Pluggable PCB terminals, TOP connection system pitch 5.00/5.08 mm

wiecon PCB

Rated cross section:
2.5 mm²

Rated current:
12 A, On state current 2.2 mA per LED

Rated voltages:
Type 8113 B/... TOP, 8213 B/... TOP
250 V/4 kV/3 – overvoltage category III
400 V/4 kV/2 – overvoltage category II
1000 V/4 kV/1 – overvoltage category I

Type 8113 B/... TOP LED
24 V/4 kV/3 – overvoltage category III
24 V/4 kV/2 – overvoltage category II
24 V/4 kV/1 – overvoltage category I

Wire range:
0.14 – 2.5 mm² single core/finely stranded

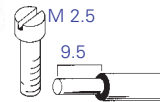
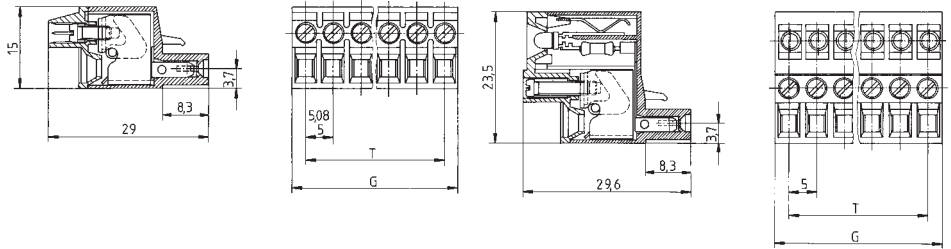

Type 8113 B/... TOP, 8213 B/... TOP
Connection in line with conductor

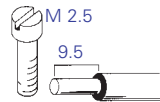

Type 8113 B/... TOP LED
Connection in line with conductor

**TOP connector
with LED
common
negative pole**

Rated voltages VDE 0110
UL Data
CSA Data
Approvals

No. 22 – 12 AWG 300 V 15 A
No. 22 – 12 AWG 300 V 15 A

No. 22 – 12 AWG 24 V 15 A
No. 22 – 12 AWG 24 V 15 A

Box Qty	TOP	G	T	Pole	Part No.	Part No.	Part No.	Part No.
Pitch 5.00 mm					unmarked	marked	unmarked	marked
100	250	10	5	2	25.220.3253.0	25.220.0253.0	25.230.3253.0	25.230.0253.0
100	250	15	10	3	25.220.3353.0	25.220.0353.0	25.230.3353.0	25.230.0353.0
50	200	20	15	4	25.220.3453.0	25.220.0453.0	25.230.3453.0	25.230.0453.0
50	200	25	20	5	25.220.3553.0	25.220.0553.0	25.230.3553.0	25.230.0553.0
50	200	30	25	6	25.220.3653.0	25.220.0653.0	25.230.3653.0	25.230.0653.0
50	100	35	30	7	25.220.3753.0	25.220.0753.0	25.230.3753.0	25.230.0753.0
50	100	40	35	8	25.220.3853.0	25.220.0853.0	25.230.3853.0	25.230.0853.0
50	100	45	40	9	25.220.3953.0	25.220.0953.0	25.230.3953.0	25.230.0953.0
50	100	50	45	10	25.220.4053.0	25.220.1053.0	25.230.4053.0	25.230.1053.0
50	100	55	50	11	25.220.4153.0	25.220.1153.0	25.230.4153.0	25.230.1153.0
50	100	60	55	12	25.220.4253.0	25.220.1253.0	25.230.4253.0	25.230.1253.0
50	50	65	60	13	25.220.4353.0	25.220.1353.0	25.230.4353.0	25.230.1353.0
50	50	70	65	14	25.220.4453.0	25.220.1453.0	25.230.4453.0	25.230.1453.0
50	50	75	70	15	25.220.4553.0	25.220.1553.0	25.230.4553.0	25.230.1553.0
50	50	80	75	16	25.220.4653.0	25.220.1653.0	25.230.4653.0	25.230.1653.0
117 to 24 pole on request								
Pitch 5.08 mm					unmarked	marked		
100	250	10.16	5.08	2	25.240.3253.0	25.240.0253.0		
100	250	15.24	10.16	3	25.240.3353.0	25.240.0353.0		
50	200	20.32	15.24	4	25.240.3453.0	25.240.0453.0		
50	200	25.40	20.32	5	25.240.3553.0	25.240.0553.0		
50	200	30.48	25.40	6	25.240.3653.0	25.240.0653.0		
50	100	35.56	30.48	7	25.240.3753.0	25.240.0753.0		
50	100	40.64	35.56	8	25.240.3853.0	25.240.0853.0		
50	100	45.72	40.64	9	25.240.3953.0	25.240.0953.0		
50	100	50.80	45.72	10	25.240.4053.0	25.240.1053.0		
50	100	55.88	50.80	11	25.240.4153.0	25.240.1153.0		
50	100	60.96	55.88	12	25.240.4253.0	25.240.1253.0		
50	50	66.04	60.96	13	25.240.4353.0	25.240.1353.0		
50	50	71.12	66.04	14	25.240.4453.0	25.240.1453.0		
50	50	76.20	71.12	15	25.240.4553.0	25.240.1553.0		
50	50	81.28	76.20	16	25.240.4653.0	25.240.1653.0		
17 to 24 pole on request								

PCB headers pitch 5.00/5.08 mm

wiecon

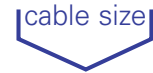

Rated current:
12 A

250 V/4 kV/3 – overvoltage category III
400 V/4 kV/2 – overvoltage category II
1000 V/4 kV/1 – overvoltage category I

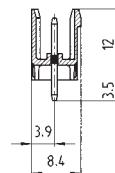
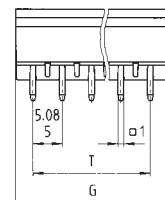
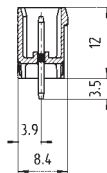
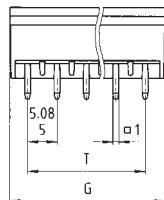

Solder pin 1 x 1 mm
Drill hole Ø 1.4 mm



Solder pin 1 x 1 mm
Drill hole Ø 1.4 mm

closed version

Type 8113 S/... G, 8213 S/... G

Connection vertical to PCB

open version

Type 8113 S/... GOF, 8213 S/... GOF

Connection vertical to PCB

Rated voltages VDE 0110
UL Data
CSA Data
Approvals

300 V 15 A
300 V 15 A



300 V 15 A
300 V 15 A

Box Qty	G	T	Pole	Part No.	G	T	Part No.
Pitch 5.00 mm				unmarked	unmarked		
100	10.16	5	2	25.330.3253.0	10	5	99.202.9996.0
100	15.24	10	3	25.330.3353.0	15	10	99.203.9996.0
50	20.32	15	4	25.330.3453.0	20	15	99.204.9996.0
50	25.40	20	5	25.330.3553.0	25	20	99.205.9996.0
50	30.48	25	6	25.330.3653.0	30	25	99.206.9996.0
50	35.56	30	7	25.330.3753.0	35	30	99.207.9996.0
50	40.64	35	8	25.330.3853.0	40	35	99.208.9996.0
50	45.72	40	9	25.330.3953.0	45	40	99.209.9996.0
50	50.80	45	10	25.330.4053.0	50	45	99.210.9996.0
50	55.88	50	11	25.330.4153.0	55	50	99.211.9996.0
50	60.96	55	12	25.330.4253.0	60	55	99.212.9996.0
50	66.04	60	13	25.330.4353.0	65	60	99.213.9996.0
50	71.12	65	14	25.330.4453.0	70	65	99.214.9996.0
50	76.20	70	15	25.330.4553.0	75	70	99.215.9996.0
50	81.28	75	16	25.330.4653.0	80	75	99.216.9996.0
17 to 24 pole on request					17 to 24 pole on request		
Pitch 5.08 mm				unmarked	unmarked		
100	11.56	5.08	2	25.350.3253.0	10.16	5.08	99.232.9996.1
100	16.64	10.16	3	25.350.3353.0	15.24	10.16	99.233.9996.1
50	21.72	15.24	4	25.350.3453.0	20.32	15.24	99.234.9996.1
50	26.80	20.32	5	25.350.3553.0	25.40	20.32	99.235.9996.1
50	31.88	25.40	6	25.350.3653.0	30.48	25.40	99.236.9996.1
50	36.96	30.48	7	25.350.3753.0	35.56	30.48	99.237.9996.1
50	42.04	35.56	8	25.350.3853.0	40.64	35.56	99.238.9996.1
50	47.12	40.64	9	25.350.3953.0	45.72	40.64	99.239.9996.1
50	52.20	45.72	10	25.350.4053.0	50.80	45.72	99.240.9996.1
50	57.28	50.80	11	25.350.4153.0	55.88	50.80	99.241.9996.1
50	62.36	55.88	12	25.350.4253.0	60.96	55.88	99.242.9996.1
50	67.44	60.96	13	25.350.4353.0	66.04	60.96	99.243.9996.1
50	72.52	66.04	14	25.350.4453.0	70.12	66.04	99.244.9996.1
50	77.60	71.12	15	25.350.4553.0	75.20	71.12	99.245.9996.1
50	82.68	76.20	16	25.350.4653.0	80.28	76.20	99.246.9996.1
17 to 24 pole on request					17 to 24 pole on request		
Accessories:							
Coding part (branch)	100			05.561.0053.0	05.561.0053.0		
Mounting bracket assembly - for double ended screw fixing of header	100			Z5.523.2453.0			

PCB headers
pitch 5.00/5.08 mm

wiecon PCB

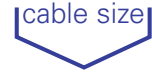

Rated current:
12 A

Rated voltages:
250 V/4 kV/3 – overvoltage category III
400 V/4 kV/2 – overvoltage category II
1000 V/4 kV/1 – overvoltage category I

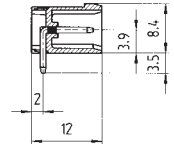
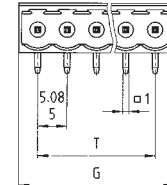
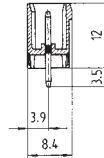
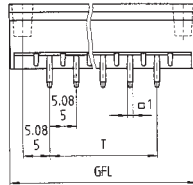

Solder pin 1 x 1 mm
Drill hole Ø 1.4 mm

with screw flange

Type 8113 S/... GF, 8213 S/... GF

Connection vertical to PCB



Solder pin 1 x 1 mm
Drill hole Ø 1.4 mm

closed version

Type 8113 S/... W, 8213 S/... W

Connection horizontal to PCB

Rated voltages VDE 0110

UL Data

CSA Data

Approvals

300 V 15 A
300 V 15 A

300 V 15 A
300 V 15 A



Box Qty	G	T	Pole	Part No.	GFL	T	Part No.
Pitch 5.00 mm				unmarked			unmarked
100	11.40	5	2	25.338.3253.0	20	5	25.332.3253.0
100	16.40	10	3	25.338.3353.0	25	10	25.332.3353.0
50	21.40	15	4	25.338.3453.0	30	15	25.332.3453.0
50	26.40	20	5	25.338.3553.0	35	20	25.332.3553.0
50	31.40	25	6	25.338.3653.0	40	25	25.332.3653.0
50	36.40	30	7	25.338.3753.0	45	30	25.332.3753.0
50	41.40	35	8	25.338.3853.0	50	35	25.332.3853.0
50	46.40	40	9	25.338.3953.0	55	40	25.332.3953.0
50	51.40	45	10	25.338.4053.0	60	45	25.332.4053.0
50	56.40	50	11	25.338.4153.0	65	50	25.332.4153.0
50	61.40	55	12	25.338.4253.0	70	55	25.332.4253.0
50	66.40	60	13	25.338.4353.0	75	60	25.332.4353.0
50	71.40	65	14	25.338.4453.0	80	65	25.332.4453.0
50	76.40	70	15	25.338.4553.0	85	70	25.332.4553.0
50	81.40	75	16	25.338.4653.0	90	75	25.332.4653.0
				17 to 22 pole on request	17 to 24 pole on request		
Pitch 5.08 mm				unmarked			unmarked
100	11.56	5.08	2	25.359.3253.0	20.32	5.08	25.352.3253.0
100	16.64	10.16	3	25.359.3353.0	25.40	10.16	25.352.3353.0
50	21.72	15.24	4	25.359.3453.0	30.48	15.24	25.352.3453.0
50	26.80	20.32	5	25.359.3553.0	35.56	20.32	25.352.3553.0
50	31.88	25.40	6	25.359.3653.0	40.64	25.40	25.352.3653.0
50	36.96	30.48	7	25.359.3753.0	45.72	30.48	25.352.3753.0
50	42.04	35.56	8	25.359.3853.0	50.80	35.56	25.352.3853.0
50	47.12	40.64	9	25.359.3953.0	55.88	40.64	25.352.3953.0
50	52.20	45.72	10	25.359.4053.0	60.96	45.72	25.352.4053.0
50	57.28	50.80	11	25.359.4153.0	66.04	50.80	25.352.4153.0
50	62.36	55.88	12	25.359.4253.0	71.12	55.88	25.352.4253.0
50	67.44	60.96	13	25.359.4353.0	76.20	60.96	25.352.4353.0
50	72.52	66.04	14	25.359.4453.0	81.28	66.04	25.352.4453.0
50	77.60	71.12	15	25.359.4553.0	86.36	71.12	25.352.4553.0
50	82.68	76.20	16	25.359.4653.0	91.44	76.20	25.352.4653.0
				17 to 22 pole on request	17 to 24 pole on request		
Accessories:							
Coding part (branch)	100			05.561.0053.0	05.561.0053.0		
Mounting bracket assembly - for double ended screw fixing of header,	100			Z5.523.2453.0	Z5.523.2453.0		

PCB header pitch 5.00/5.08 mm

wiecon

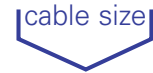

Rated current:
12 A

250 V/4 kV/3 – overvoltage category III
400 V/4 kV/2 – overvoltage category II
1000 V/4 kV/1 – overvoltage category I

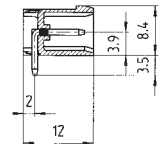
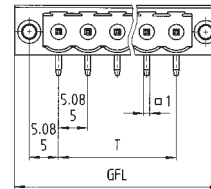
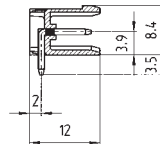
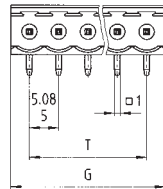

Solder pin 1 x 1 mm
Drill hole Ø 1.4 mm

open version

Type 8113 S/... WOF, 8213 S/... WOF
Connection horizontal to PCB



Solder pin 1 x 1 mm
Drill hole Ø 1.4 mm

with screw flange

Type 8113 S/... WF, 8213 S/... WF
Connection horizontal to PCB

Rated voltages VDE 0110
UL Data
CSA Data
Approvals

300 V 15 A
300 V 15 A



300 V 15 A
300 V 15 A

	Box Qty	G	T	Pole	Part No.	GFL	G	T	Part No.
Pitch 5.00 mm					unmarked				unmarked
	100	11.40	5	2	99.262.9996.0	20	10	5	25.339.3253.0
	100	16.40	10	3	99.263.9996.0	25	15	10	25.339.3353.0
	50	21.40	15	4	99.264.9996.0	30	20	15	25.339.3453.0
	50	26.40	20	5	99.265.9996.0	35	25	20	25.339.3553.0
	50	31.40	25	6	99.266.9996.0	40	30	25	25.339.3653.0
	50	36.40	30	7	99.267.9996.0	45	35	30	25.339.3753.0
	50	41.40	35	8	99.268.9996.0	50	40	35	25.339.3853.0
	50	46.40	40	9	99.269.9996.0	55	45	40	25.339.3953.0
	50	51.40	45	10	99.270.9996.0	60	50	45	25.339.4053.0
	50	56.40	50	11	99.271.9996.0	65	55	50	25.339.4153.0
	50	61.40	55	12	99.272.9996.0	70	60	55	25.339.4253.0
	50	66.40	60	13	99.273.9996.0	75	65	60	25.339.4353.0
	50	71.40	65	14	99.274.9996.0	80	70	65	25.339.4453.0
	50	76.40	70	15	99.275.9996.0	85	75	70	25.339.4553.0
	50	81.40	75	16	99.276.9996.0	90	80	75	25.339.4653.0
	17 to 24 pole on request					17 to 22 pole on request			
Pitch 5.08 mm					unmarked				unmarked
	100	11.56	5.08	2	99.202.9996.2	20.32	10.16	5.08	25.358.3253.0
	100	16.64	10.16	3	99.203.9996.2	25.40	15.24	10.16	25.358.3353.0
	50	21.72	15.24	4	99.204.9996.2	30.48	20.32	15.24	25.358.3453.0
	50	26.80	20.32	5	99.205.9996.2	35.56	25.40	20.32	25.358.3553.0
	50	31.88	25.40	6	99.206.9996.2	40.64	30.48	25.40	25.358.3653.0
	50	36.96	30.48	7	99.207.9996.2	45.72	35.56	30.48	25.358.3753.0
	50	42.04	35.56	8	99.208.9996.2	50.80	40.64	35.56	25.358.3853.0
	50	47.12	40.64	9	99.209.9996.2	55.88	45.72	40.64	25.358.3953.0
	50	52.20	45.72	10	99.210.9996.2	60.96	50.80	45.72	25.358.4053.0
	50	57.28	50.80	11	99.211.9996.2	66.04	55.88	50.80	25.358.4153.0
	50	62.36	55.88	12	99.212.9996.2	71.12	60.96	55.88	25.358.4253.0
	50	67.44	60.96	13	99.213.9996.2	76.20	66.04	60.96	25.358.4353.0
	50	72.52	66.04	14	99.214.9996.2	81.28	71.12	66.04	25.358.4453.0
	50	77.60	71.12	15	99.215.9996.2	86.36	76.20	71.12	25.358.4553.0
	50	82.68	76.20	16	99.216.9996.2	91.44	81.28	76.20	25.358.4653.0
	17 to 24 pole on request					17 to 22 pole on request			
Accessories:									
Coding part (branch)	100				05.561.0053.0	05.561.0053.0			
Mounting bracket assembly - for double ended screw fixing of header	100				Z5.523.2453.0				

PCB headers pitch 7.50/7.62 mm

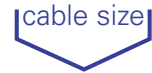

wiecon PCB

Rated current:
12 A

250 V/4 kV/3 – overvoltage category III
400 V/4 kV/2 – overvoltage category II
1000 V/4 kV/1 – overvoltage category I

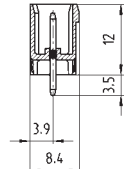
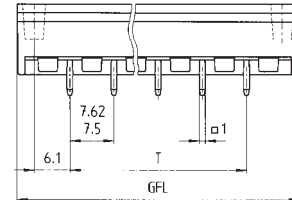
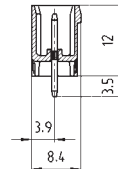
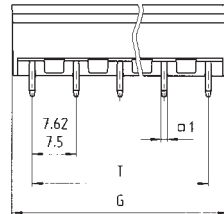

Solder pin 1 x 1 mm
Drill hole Ø 1.4 mm

closed version

Type 8313 S/... G, 8413 S/... G

Connection vertical to PCB



Solder pin 1 x 1 mm
Drill hole Ø 1.4 mm

with screw flange

Type 8313 S/... GF, 8413 S/... GF

Connection vertical to PCB

Rated voltages VDE 0110

UL Data

CSA Data

Approvals

300 V 15 A
300 V 15 A

300 V 15 A
300 V 15 A



Box Qty	G	T	Pole	Part No.	GFL	T	Part No.
Pitch 7.50 mm				unmarked			unmarked
100	14.20	7.50	2	25.370.3253.0	25.54	7.50	25.374.6253.0
100	21.70	15.00	3	25.370.3353.0	33.04	15.00	25.374.6353.0
50	29.20	22.50	4	25.370.3453.0	40.54	22.50	25.374.6453.0
50	36.70	30.00	5	25.370.3553.0	48.04	30.00	25.374.6553.0
50	44.20	37.50	6	25.370.3653.0	55.54	37.50	25.374.6653.0
50	51.70	45.00	7	25.370.3753.0	63.04	45.00	25.374.6753.0
50	59.20	52.50	8	25.370.3853.0	70.54	52.50	25.374.6853.0
50	66.70	60.00	9	25.370.3953.0	78.04	60.00	25.374.6953.0
50	74.20	67.50	10	25.370.4053.0	85.54	67.50	25.374.7053.0
50	81.70	75.00	11	25.370.4153.0	93.04	75.00	25.374.7153.0
50	89.20	82.50	12	25.370.4253.0	100.54	82.50	25.374.7253.0
Pitch 7.62 mm				unmarked			unmarked
100	14.32	7.62	2	25.390.3253.0	25.66	7.62	25.398.6253.0
100	21.94	15.24	3	25.390.3353.0	33.25	15.24	25.398.6353.0
50	29.56	22.86	4	25.390.3453.0	40.90	22.86	25.398.6453.0
50	37.18	30.48	5	25.390.3553.0	48.52	30.48	25.398.6553.0
50	44.80	38.10	6	25.390.3653.0	56.14	38.10	25.398.6653.0
50	52.42	45.72	7	25.390.3753.0	63.76	45.72	25.398.6753.0
50	60.04	53.34	8	25.390.3853.0	71.38	53.34	25.398.6853.0
50	67.66	60.64	9	25.390.3953.0	79.00	60.64	25.398.6953.0
50	75.28	68.58	10	25.390.4053.0	86.62	68.58	25.398.7053.0
50	82.90	76.20	11	25.390.4153.0	94.24	76.20	25.398.7153.0
50	90.52	83.82	12	25.390.4253.0	101.86	83.82	25.398.7253.0
Accessories:							
Coding part (branch)	100			05.561.0053.0	05.561.0053.0		
Mounting bracket assembly - for double ended screw fixing of header	100			Z5.523.2453.0			

PCB headers pitch 7.50/7.62 mm

wiecon

cable size

Rated current:
12 A

400 V/6 kV/3 – overvoltage category III
690 V/6 kV/2 – overvoltage category II
1000 V/6 kV/1 – overvoltage category I

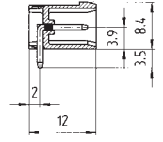
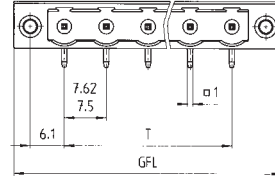
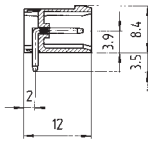
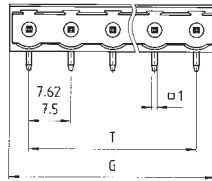

Solder pin 1 x 1 mm
Drill hole Ø 1.4 mm

closed version

Type 8313 S/... W, 8413 S/... W

Connection horizontal to PCB



Solder pin 1 x 1 mm
Drill hole Ø 1.4 mm

with screw flange

Type 8313 S/... WF, 8413 S/... WF

Connection horizontal to PCB

Rated voltages VDE 0110

UL Data

CSA Data

Approvals

300 V 15 A
300 V 15 A



300 V 15 A
300 V 15 A

Box Qty	G	T	Pole	Part No.	GFL	T	Part No.
Pitch 7.50 mm				unmarked	unmarked		
100	14.40	7.50	2	25.372.3253.0	25.54	7.50	25.374.2253.0
100	21.90	15.00	3	25.372.3353.0	33.04	15.00	25.374.2353.0
50	29.40	22.50	4	25.372.3453.0	40.54	22.50	25.374.2453.0
50	36.90	30.00	5	25.372.3553.0	48.04	30.00	25.374.2553.0
50	44.40	37.50	6	25.372.3653.0	55.54	37.50	25.374.2653.0
50	51.90	45.00	7	25.372.3753.0	63.04	45.00	25.374.2753.0
50	59.40	52.50	8	25.372.3853.0	70.54	52.50	25.374.2853.0
50	66.90	60.00	9	25.372.3953.0	78.04	60.00	25.374.2953.0
50	74.40	67.50	10	25.372.4053.0	85.54	67.50	25.374.3053.0
50	81.90	75.00	11	25.372.4153.0	93.04	75.00	25.374.3153.0
50	89.40	82.50	12	25.372.4253.0	100.54	82.50	25.374.3253.0
Pitch 7.62 mm				unmarked	unmarked		
100	14.52	7.62	2	25.392.3253.0	25.66	7.62	25.398.2253.0
100	22.14	15.24	3	25.392.3353.0	33.25	15.24	25.398.2353.0
50	29.76	22.86	4	25.392.3453.0	40.90	22.86	25.398.2453.0
50	37.38	30.48	5	25.392.3553.0	48.52	30.48	25.398.2553.0
50	45.00	38.10	6	25.392.3653.0	56.14	38.10	25.398.2653.0
50	52.62	45.72	7	25.392.3753.0	63.76	45.72	25.398.2753.0
50	60.24	53.34	8	25.392.3853.0	71.38	53.34	25.398.2853.0
50	67.86	60.96	9	25.392.3953.0	79.00	60.96	25.398.2953.0
50	75.48	68.58	10	25.392.4053.0	86.62	68.58	25.398.3053.0
50	83.10	76.20	11	25.392.4153.0	94.24	76.20	25.398.3153.0
50	90.72	83.82	12	25.392.4253.0	101.86	83.82	25.398.3253.0
Accessories:							
Coding part (branch)	100			05.561.0053.0	05.561.0053.0		
Mounting bracket assembly - for double ended screw fixing of header	100			Z5.523.2453.0			

PCB headers
pitch 5.00/5.08 mm

wiecon PCB

cable size

Rated current:
12 A

250 V/4 kV/3 – overvoltage category III
400 V/4 kV/2 – overvoltage category II
1000 V/4 kV/1 – overvoltage category I

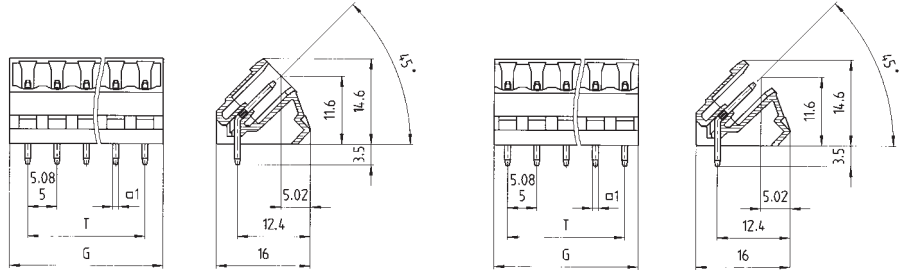

Solder pin 1 x 1 mm
Drill hole Ø 1.4 mm



Solder pin 1 x 1 mm
Drill hole Ø 1.4 mm

closed version

open version

Type 8113 S/... S, 8213 S/... S

Type 8113 S/... S1, 8213 S/... S1

Connection at 45° to PCB

Connection at 45° to PCB

Rated voltages VDE 0110

UL Data

CSA Data

Approvals

300 V 15 A
300 V 15 A

300 V 15 A
300 V 15 A



Box Qty	G	T	Pole	Part No.	G	T	Part No.
Pitch 5.00 mm				unmarked	unmarked		
100	11.20	5	2	25.394.3253.0	9.60	5	25.395.3253.0
100	16.20	10	3	25.394.3353.0	14.60	10	25.395.3353.0
50	21.20	15	4	25.394.3453.0	19.60	15	25.395.3453.0
50	26.20	20	5	25.394.3553.0	24.60	20	25.395.3553.0
50	31.20	25	6	25.394.3653.0	29.60	25	25.395.3653.0
50	36.20	30	7	25.394.3753.0	34.60	30	25.395.3753.0
50	41.20	35	8	25.394.3853.0	39.60	35	25.395.3853.0
50	46.20	40	9	25.394.3953.0	44.60	40	25.395.3953.0
50	51.20	45	10	25.394.4053.0	49.60	45	25.395.4053.0
50	56.20	50	11	25.394.4153.0	54.60	50	25.395.4153.0
50	61.20	55	12	25.394.4253.0	59.60	55	25.395.4253.0
50	66.20	60	13	25.394.4353.0	64.60	60	25.395.4353.0
50	71.20	65	14	25.394.4453.0	69.60	65	25.395.4453.0
50	76.20	70	15	25.394.4553.0	74.60	70	25.395.4553.0
50	81.20	75	16	25.394.4653.0	79.60	75	25.395.4653.0
17 to 24 pole on request							
Pitch 5.08 mm				unmarked	unmarked		
100	11.36	5.08	2	25.396.3253.0	9.76	5.08	25.397.3253.0
100	16.44	10.16	3	25.396.3353.0	14.84	10.16	25.397.3353.0
50	21.52	15.24	4	25.396.3453.0	19.92	15.24	25.397.3453.0
50	26.60	20.32	5	25.396.3553.0	25.00	20.32	25.397.3553.0
50	31.68	25.40	6	25.396.3653.0	30.08	25.40	25.397.3653.0
50	36.76	30.48	7	25.396.3753.0	35.16	30.48	25.397.3753.0
50	41.84	35.56	8	25.396.3853.0	40.24	35.56	25.397.3853.0
50	46.92	40.64	9	25.396.3953.0	45.32	40.64	25.397.3953.0
50	52.00	45.72	10	25.396.4053.0	50.40	45.72	25.397.4053.0
50	57.08	50.80	11	25.396.4153.0	55.48	50.80	25.397.4153.0
50	62.19	55.88	12	25.396.4253.0	60.56	55.88	25.397.4253.0
50	67.24	60.96	13	25.396.4353.0	65.64	60.96	25.397.4353.0
50	72.32	66.04	14	25.396.4453.0	70.72	66.04	25.397.4453.0
50	77.40	71.12	15	25.396.4553.0	75.80	71.12	25.397.4553.0
50	82.48	76.20	16	25.396.4653.0	80.88	76.20	25.397.4653.0
17 to 24 pole on request							
Accessories:							
Coding part (branch)	100			05.561.0053.0			05.561.0053.0

PCB headers pitch 5.00/5.08 mm



Rated current:
10 A

250 V/4 kV/3 – overvoltage category III
400 V/4 kV/2 – overvoltage category II
1000 V/4 kV/1 – overvoltage category I

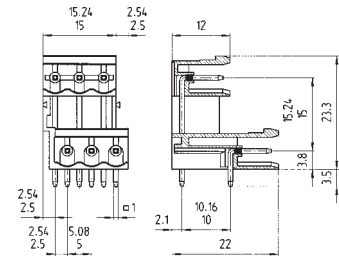
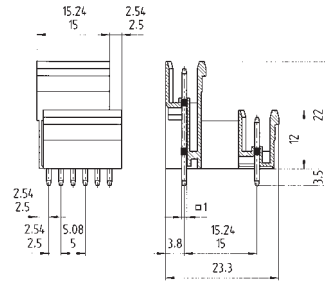

Solder pin 1 x 1 mm
Drill hole Ø 1.4 mm



Solder pin 1 x 1 mm
Drill hole Ø 1.4 mm

Type 8113 SE/... G, 8213 SE/... G

Connection vertical to PCB

Type 8113 SE/... W, 8213 SE/... W

Connection horizontal to PCB

Rated voltages VDE 0110

UL Data

CSA Data

Approvals

300 V 15 A
300 V 10 A

300 V 15 A
300 V 10 A



Box Qty	T	Pole	Part No.	Part No.
Pitch 5.00 mm				
			unmarked	unmarked
100	5	2 x 2	25.334.3253.0	25.336.3253.0
100	10	2 x 3	25.334.3353.0	25.336.3353.0
Larger pole numbers can be achieved by latching together				
Pitch 5.08 mm				
			unmarked	unmarked
100	5.08	2 x 2	25.354.3253.0	25.356.3253.0
100	10.16	2 x 3	25.354.3353.0	25.356.3353.0
Larger pole numbers can be achieved by latching together				
Accessories:				
End plate	50		07.310.9853.0	07.310.9853.0
Mounting bracket assembly - for double ended screw fixing of header			on request	Only in connection with end plate 07.310.9853.0 Z5.523.2453.0

PCB Headers
pitch 5.00/5.08 mm

wiecon PCB

Rated current: 10 A

250 V/4 kV/3 – overvoltage category III
400 V/4 kV/2 – overvoltage category III
400 V/4 kV/2 – overvoltage category II

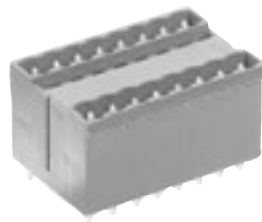
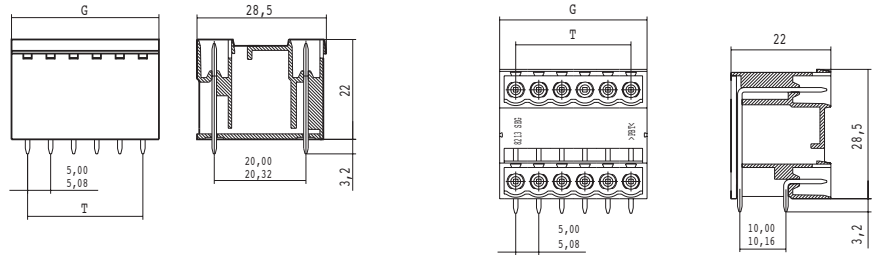

Solder pin 1 x 1 mm
Drill hole Ø 1.3 mm



Solder pin 1 x 1 mm
Drill hole Ø 1.3 mm

Type 81-8213 SEG .../G

Type 81-8213 SEG .../W

Rated voltages VDE 0110
UL Data
CSA Data
Approvals

300 V 10 A
300 V 10 A

300 V 10 A
300 V 10 A



Box Qty	G	T	Pole	Part No.	Part No.
Pitch 5.00 mm				unmarked	unmarked
100	12	5	4	27.334.0253.0	27.336.0253.0
100	17	10	6	27.334.0353.0	27.336.0353.0
50	22	15	8	27.334.0453.0	27.336.0453.0
50	27	20	10	27.334.0553.0	27.336.0553.0
50	32	25	12	27.334.0653.0	27.336.0653.0
50	37	30	14	27.334.0753.0	27.336.0753.0
50	42	35	16	27.334.0853.0	27.336.0853.0
50	47	40	18	27.334.0953.0	27.336.0953.0
50	52	45	20	27.334.1053.0	27.336.1053.0
50	57	50	22	27.334.1153.0	27.336.1153.0
50	62	55	24	27.334.1253.0	27.336.1253.0
50	67	60	26	27.334.1353.0	27.336.1353.0
50	72	65	28	27.334.1453.0	27.336.1453.0
50	77	70	30	27.334.1553.0	27.336.1553.0
50	82	75	32	27.334.1653.0	27.336.1653.0
1 to 24 pole on request					
Pitch 5.08 mm				unmarked	unmarked
100	12.16	5.08	4	27.354.0253.0	27.356.0253.0
100	17.24	10.16	6	27.354.0353.0	27.356.0353.0
50	22.32	15.24	8	27.354.0453.0	27.356.0453.0
50	27.40	20.32	10	27.354.0553.0	27.356.0553.0
50	32.48	25.40	12	27.354.0653.0	27.356.0653.0
50	37.56	30.48	14	27.354.0753.0	27.356.0753.0
50	42.64	35.56	16	27.354.0853.0	27.356.0853.0
50	47.72	40.64	18	27.354.0953.0	27.356.0953.0
50	52.80	45.72	20	27.354.1053.0	27.356.1053.0
50	57.88	50.80	22	27.354.1153.0	27.356.1153.0
50	62.96	55.88	24	27.354.1253.0	27.356.1253.0
50	68.04	60.96	26	27.354.1353.0	27.356.1353.0
50	73.12	66.04	28	27.354.1453.0	27.356.1453.0
50	78.20	71.12	30	27.354.1553.0	27.356.1553.0
50	83.28	76.20	32	27.354.1653.0	27.356.1653.0
1 to 24 pole on request					
				Coding available on request	Coding available on request

Headers for panel mounting, pitch 5.08 mm

wiecon

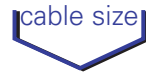

Wire wrap connection 1 x 1

Max. diameter of interconnecting wire Ø: 0.8 mm

Rated current: 6.5 A

Solder connection

Rated cross section
1.5 mm² single core/
1.0 mm² finely stranded

Rated current: 12 A

Plug connection 2.8 x 0.8 DIN 46249

Rated cross section
1.0 mm² finely stranded

Rated current: 8 A

250 V/4 kV/3 – overvoltage category III
400 V/4 kV/2 – overvoltage category II
1000 V/4 kV/1 – overvoltage category I

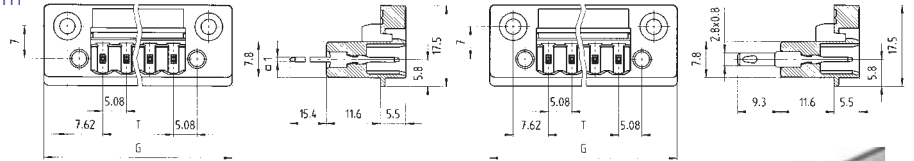

Wire-Wrap

**Type 8213 S/... DFWW,
8213 S/... DFWW M**



with solder connection

**Type 8213 S/... DFLS,
8213 S/... DFLS M**

Rated voltages VDE 0110

UL Data

CSA Data

Approvals

No. 22 – 12 AWG

300 V

6.5 A

No. 22 – 12 AWG

300 V

6.5 A



No. 22 – 12 AWG

300 V

12/8 A

No. 22 – 12 AWG

300 V

12/8 A



Box Qty	G	T	Pole	Part No.	Part No.	Part No.	Part No.
Pitch 5.08 mm							
				unmarked	unmarked	unmarked	unmarked
100	30.48	5.08	2	25.303.0253.0	25.313.0253.0	25.303.3253.0	25.313.3253.0
100	35.56	10.16	3	25.303.0353.0	25.313.0353.0	25.303.3353.0	25.313.3353.0
50	40.64	15.24	4	25.303.0453.0	25.313.0453.0	25.303.3453.0	25.313.3453.0
50	45.72	20.32	5	25.303.0553.0	25.313.0553.0	25.303.3553.0	25.313.3553.0
50	50.80	25.40	6	25.303.0653.0	25.313.0653.0	25.303.3653.0	25.313.3653.0
50	55.88	30.48	7	25.303.0753.0	25.313.0753.0	25.303.3753.0	25.313.3753.0
50	60.96	35.56	8	25.303.0853.0	25.313.0853.0	25.303.3853.0	25.313.3853.0
50	66.04	40.64	9	25.303.0953.0	25.313.0953.0	25.303.3953.0	25.313.3953.0
50	71.12	45.72	10	25.303.1053.0	25.313.1053.0	25.303.4053.0	25.313.4053.0
50	76.20	50.80	11	25.303.1153.0	25.313.1153.0	25.303.4153.0	25.313.4153.0
50	81.28	55.88	12	25.303.1253.0	25.313.1253.0	25.303.4253.0	25.313.4253.0
50	86.36	60.96	13	25.303.1353.0	25.313.1353.0	25.303.4353.0	25.313.4353.0
50	91.44	66.04	14	25.303.1453.0	25.313.1453.0	25.303.4453.0	25.313.4453.0
50	96.52	71.12	15	25.303.1553.0	25.313.1553.0	25.303.4553.0	25.313.4553.0
50	101.60	76.20	16	25.303.1653.0	25.313.1653.0	25.303.4653.0	25.313.4653.0
17 to 22 pole on request				without press in nut	with press in nut for screw flange	without press in nut	with press in nut for screw flange
Dimensions for panel cut out							
	a	b					
	13.18	20.32	2				
	18.26	25.40	3				
	23.34	30.48	4				
	28.42	35.56	5				
	33.50	40.64	6				
	38.58	45.72	7				
	43.66	50.80	8				
	48.74	55.88	9				
	53.82	60.96	10				
	58.90	66.04	11				
	68.98	71.12	12				
	69.06	76.20	13				
	74.14	81.28	14				
	79.22	86.36	15				
	84.30	91.44	16				
1 to 24 pole on request							
Accessories:							
Coding part (branch)	100			05.561.0053.0		05.561.0053.0	
Screw assembly	100			Z6.012.0812.0		Z6.012.0812.0	

Accessories for 8113 – 8413/8813 and 8213 BL

wiecon PCB

Drilling plan for mounting bracket Z5.523.2453.0

Type 8113 SE/... and 8213 SE/...

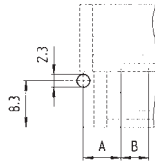

	A	B
8113	6.3	5.00
8213	6.8	5.08

Drilling plan for mounting bracket Z5.523.2453.0



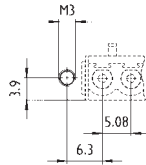
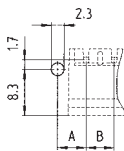
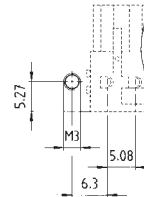
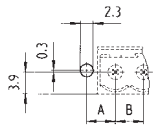





Type 81 – 8413 S/...



	A	B
8113	5.1	5.00
8213	5.2	5.08
8313	5.4	7.50
8413	5.4	7.62

8113 – 8413/8813

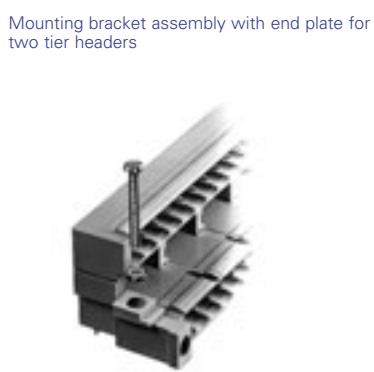
8213 BL

8113 – 8413/8813		8213 BL																												
Part No.	Box Qty	Part No.	Box Qty																											
 <p>Mounting bracket (Type 8113 – 8413)</p>	Z5.523.2453.0 100	<p>Adhesive marking strips for socket connectors and headers with 5/5.08 mm pitch</p> 																												
 <p>End plate for two tier header (Type 8113 – 8213 SE)</p>	07.310.9853.0 50	<table border="0"> <tr><td>1 – 12</td><td>04.007.4089.0</td><td>1</td></tr> <tr><td>13 – 24</td><td>04.007.4189.0</td><td>1</td></tr> <tr><td>25 – 36</td><td>04.007.4289.0</td><td>1</td></tr> <tr><td>37 – 68</td><td>04.007.4389.0</td><td>1</td></tr> <tr><td>49 – 60</td><td>04.007.4489.0</td><td>1</td></tr> <tr><td>61 – 72</td><td>04.007.4589.0</td><td>1</td></tr> <tr><td>73 – 84</td><td>04.007.4689.0</td><td>1</td></tr> <tr><td>85 – 96</td><td>04.007.4789.0</td><td>1</td></tr> <tr><td>97 – 108</td><td>04.007.4889.0</td><td>1</td></tr> </table>		1 – 12	04.007.4089.0	1	13 – 24	04.007.4189.0	1	25 – 36	04.007.4289.0	1	37 – 68	04.007.4389.0	1	49 – 60	04.007.4489.0	1	61 – 72	04.007.4589.0	1	73 – 84	04.007.4689.0	1	85 – 96	04.007.4789.0	1	97 – 108	04.007.4889.0	1
1 – 12	04.007.4089.0	1																												
13 – 24	04.007.4189.0	1																												
25 – 36	04.007.4289.0	1																												
37 – 68	04.007.4389.0	1																												
49 – 60	04.007.4489.0	1																												
61 – 72	04.007.4589.0	1																												
73 – 84	04.007.4689.0	1																												
85 – 96	04.007.4789.0	1																												
97 – 108	04.007.4889.0	1																												
 <p>Coding branch for header (Type 8113 – 8413, Type 8813)</p>	05.561.0053.0 a 100																													
 <p>– socket connector (Type 8113 – 8413)</p>	05.561.9153.0 100																													
 <p>Mounting bracket assembly for headers</p>	 <p>Mounting bracket assembly with end plate for two tier headers</p>	 <p>Z5.523.7753.0 100</p>  <p>Z5.523.7853.0 100</p>																												

wiecon

Duo modular terminals, spring clamp with headers for pluggable PCB terminals

wiecon PCB

For PCB terminals 8113 BFK

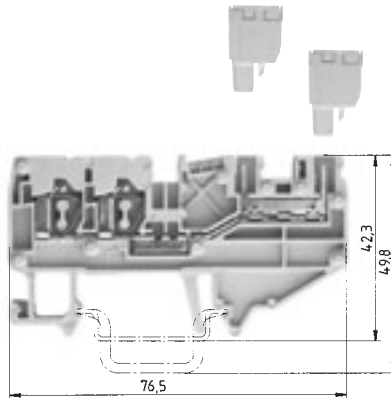

WKF 2.5 D2/8113/35

finely stranded single core V A
 0.13 – 2.5 mm² 0.13 – 4 mm² 250 V/4 kV/3 16
 No. 22 – 12 AWG 300 15
 No. 24 – 12 AWG 300 15
 5 mm 11 mm

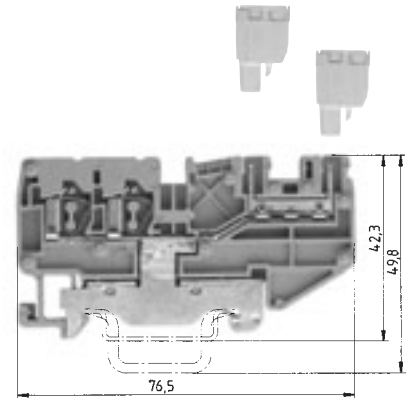

WKF 2.5 D2/8113 SL/35

finely stranded single core V A
 0.13 – 2.5 mm² 0.13 – 4 mm² 250 V/4 kV/3 16
 No. 22 – 12 AWG 300
 No. 24 – 12 AWG 300
 5 mm 11 mm



EN 60 947-7-1/DIN VDE 0611 T1
 UL Data field/factory wiring
 CSA Data
 Width stripping length
 Approvals

		Type	Part No.	Box Qty	Type	Part No.	Box Qty
Duo modular terminal	Colour: grey	WKF 2,5 D2/8113/35	56.703.2053.0	100			
	Colour: blue	WKF 2,5 D2/8113/35 BLAU	56.703.2053.6	100			
Duo earth terminal	Colour: yellow/green				WKF 2,5 D2/8113 SL/35	56.703.9253.0	100
Double deck terminal	Colour: grey						
Accessories							
1. Mounting rail 35, DIN rail 75 high	L = 2 m	35x27x7,5 EN 60715	98.300.0000.0	1	35x27x7,5 EN 60715	98.300.0000.0	1
	L = 2 m	35x24x15 EN 60715	98.360.0000.0	1	35x24x15 EN 60715	98.360.0000.0	1
2. End clamp TS 35, with screw	8 mm wide	9708/2 S35	Z5.522.8553.0	100	9708/2 S35	Z5.522.8553.0	100
	8 mm wide	WEF 1/35	Z5.523.9353.0	100	WEF 1/35	Z5.523.9353.0	100
3. End plate	Colour: grey	APF 2,5/D2/8113	07.312.4153.0	10	APF 2,5/D2/8113	07.312.4153.0	10
	Colour: blue	APF 2,5/D2/8113	07.312.4153.6	10			
4. Partition plate	Colour: grey						
	Colour: blue						
5. Jumper bar	2 pole	IVB WKF 2,5 – 2	Z7.280.6227.0	10			
	insulated	3 pole	IVB WKF 2,5 – 3	Z7.280.6327.0	10		
		4 pole	IVB WKF 2,5 – 4	Z7.280.6427.0	10		
		5 pole	IVB WKF 2,5 – 5	Z7.280.6527.0	10		
		6 pole	IVB WKF 2,5 – 6	Z7.280.6627.0	10		
		7 pole	IVB WKF 2,5 – 7	Z7.280.6727.0	20		
		8 pole	IVB WKF 2,5 – 8	Z7.280.6827.0	20		
6. Conductor entry strip	0.13 – 0.2 mm ²	LEL 2,5/1 WEISS	05.561.6553.0	100	LEL 2,5/1 WEISS	05.561.6553.0	100
	0.25 – 0.5 mm ²	LEL 2,5/2 GRAU	05.561.6653.0	100	LEL 2,5/2 GRAU	05.561.6653.0	100
	0.75 – 1.0 mm ²	LEL 2,5/3 SCHWARZ	05.561.6753.0	100	LEL 2,5/3 SCHWARZ	05.561.6753.0	100
7. Cover with warning symbol for 4 terminals		ADF 2,5/4 GELB	04.343.6053.8	10	ADF 2,5/4 GELB	04.343.6053.8	10
	Pin cover with warning symbol for 4 pole	AD 8113/4 GELB	04.343.6853.8	10	AD 8113/4 GELB	04.343.6853.8	10
8. Screwdriver, uninsulated		DIN 5264 B 0,6x3,5	06.502.4000.0	5	DIN 5264 B 0,6x3,5	06.502.4000.0	5
9. Coding part (branch)			05.561.0053.0	100		05.561.0053.0	100
10. Labelling systems		See page 36 of fasis			See page 36 of fasis		
Please see note on page 36 on fasis !							

wiecon

PCB terminal – pluggable spring clamp system pitch 5.00 mm

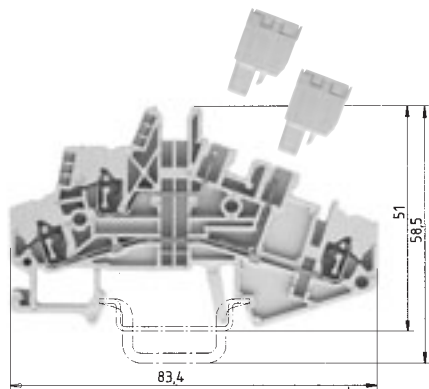

WKF 1.5 E/8113/35

finely stranded single core V A
 0.13 – 1.5 mm² 0.13 – 2.5 mm² 250 V/4 kV/3 16
 No. 22 – 14
 No. 24 – 14
 5 mm 11 mm

Rated current:
12 A

250 V/4 kV/3 – overvoltage category III
 400 V/4 kV/2 – overvoltage category II
 1000 V/4 kV/1 – overvoltage category I

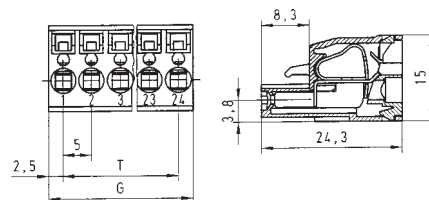

when using ferrules for wire range 2.5 mm², use only ferrules with part number 05.596.6127.0

See pages 796 to 797 **facts & DATA**



Rated voltages VDE 0110
 EN 60 947-7-1/DIN VDE 0611 T1
 Pitch stripping length
 UL Data
 CSA Data
 Approvals in preparation

Type 8113 BFK

0.13–2.5 mm² finely stranded 0.13–4 mm² single core
 11 mm 9 mm
 No. 22 – 12 AWG 300 V 12 A
 No. 22 – 12 AWG 300 V 12 A



Type	Part No.	Box Qty	Box Qty	G	T	Pole	Part No.	Part No.
			Pitch 5.00 mm				unmarked	marked
			100	10	5	2	25.820.3253.0	25.820.0253.0
			100	15	10	3	25.820.3353.0	25.820.0353.0
			50	20	15	4	25.820.3453.0	25.820.0453.0
			50	25	20	5	25.820.3553.0	25.820.0553.0
			50	30	25	6	25.820.3653.0	25.820.0653.0
			50	35	30	7	25.820.3753.0	25.820.0753.0
35x27x7,5 EN 60715	98.300.0000.0	1	50	40	35	8	25.820.3853.0	25.820.0853.0
35x24x15 EN 60715	98.360.0000.0	1	50	45	40	9	25.820.3953.0	25.820.0953.0
9708/2 S35	Z5.522.8553.0	100	50	50	45	10	25.820.4053.0	25.820.1053.0
WEF 1/35	Z5.523.9353.0	100	50	55	50	11	25.820.4153.0	25.820.1153.0
APF 1,5/E/8113	07.312.4753.0	10	50	60	55	12	25.820.4253.0	25.820.1253.0
			50	65	60	13	25.820.4353.0	25.820.1353.0
			50	70	65	14	25.820.4453.0	25.820.1453.0
			50	75	70	15	25.820.4553.0	25.820.1553.0
			50	80	75	16	25.820.4653.0	25.820.1653.0
			1 to 24 pole on request					
IVB WKF 2,5 – 2	Z7.280.6227.0	10						
IVB WKF 2,5 – 3	Z7.280.6327.0	10						
IVB WKF 2,5 – 4	Z7.280.6427.0	10						
IVB WKF 2,5 – 5	Z7.280.6527.0	10						
IVB WKF 2,5 – 6	Z7.280.6627.0	10						
IVB WKF 2,5 – 7	Z7.280.6727.0	20						
IVB WKF 2,5 – 8	Z7.280.6827.0	20						
IVB WKF 2,5 – 9	Z7.280.6927.0	20						
IVB WKF 2,5 – 10	Z7.280.7027.0	20						
LEL 1,5/1 WEISS	05.562.2453.0	100						
LEL 1,5/2 GRAU	05.562.2553.0	100						
LEL 1,5/3 SCHWARZ	05.562.2653.0	100						
ADF 2,5/4 GELB	04.343.6053.8	10						
AD 8113/4 GELB	04.343.6853.8	10						
DIN 5264 B 0,6x3,5	06.502.4000.0	5						
	05.561.0053.0	100						
See page 37 of fasis								
			Accessories:					
			Coding branch (branch)	100			05.561.9153.0	
			Screwdriver DIN 5264 B 0.6 x 3.5	5			06.502.4000.0	

Modular terminals, rising cage clamp with headers for pluggable PCB terminals

wiecon PCB

for PCB terminals:

- Type 8113 B
- Type 8113 BFK
- Type 8313 B
- Type 8113 B/VL
- Type 8113 B/VR
- Type 8113 B/Top

Indicator: R = 4.7 K; 0.5 W
LED colour: red

¹⁾ determined by LED at terminal

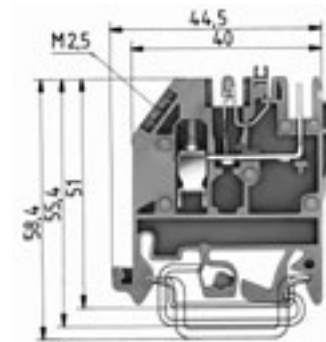
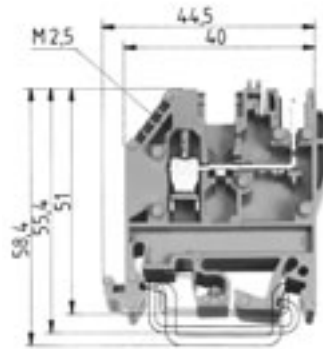

The items marked with ***) have insulating housing in accordance with UL 94-V0 (flammability class)

WK 2.5 U / 8113 S/V

finely stranded single core V A
0.5 – 2.5 mm² 0.5 – 4 mm² 250 V/4 kV/3 12
No. 22 – 12 AWG 300 V 15
No. 24 – 12 AWG 300 V 15
5 mm 9 mm



WK 2.5 U / 8113 S/V / LED 25

finely stranded single core V A
0.5 – 2.5 mm² 0.5 – 4 mm² ¹⁾ 12
No. 22 – 12 AWG 300 V 15
No. 24 – 12 AWG 25 V 15
5 mm 9 mm



EN 60 947-7-1/DIN VDE 0611 T1

UL Data

CSA Data

Width

stripping length

Approvals

		Type	Part No.	Box Qty	Type	Part No.	Box Qty
Modular terminal	Colour: grey	WK 2,5 U/8113 S/V... ***)	57.503.2655.6	50			
Modular terminal with LED 25 V	Colour: grey				WK 2,5 U/8113 S/V/LED 25 ***)	57.503.2755.0	50
Modular terminal with LED 50 V	Colour: grey						
Supply terminal	Colour: blue						
Modular terminal with header							
PCB terminals type 8113 see page 297							
Accessories							
Mounting rail 35 DIN rail 7.5 mm high	L = 2 m						
Mounting rail 35 DIN rail 15 mm high	L = 2 m						
Mounting rail 32 G-rail	L = 2 m						
End clamp with U-foot	10 mm wide						
End clamp TS 35 with screw	8 mm wide						
End clamp TS 32 with screw	7.5 mm wide						
End plate right 2.5 mm thick	Colour: grey	AP 2,5 U/8113 S/V ***)	07.312.1555.0	10	AP 2,5 U/8113 S/V ***)	07.312.1555.0	10
End plate links 2.5 mm thick	Colour: grey	AP 2,5 U/8113 ***)	07.312.4655.0	10	AP 2,5 U/8113 ***)	07.312.4655.0	10
End plate 2.5 mm thick	Colour: blue						
Right intermediate plate 2.5 mm thick	Colour: grey	ZP 2,5 U/8113 S/V	07.312.1655.0	10	ZP 2,5 U/8113 S/V	07.312.1655.0	10
Intermediate plate 2.5 mm thick	Colour: blue						
(for use of PCB terminals with 7.5 mm)							
Jumper bar with screws, E-Cu	insulated						
	2 pole	IVB WK 2,5-2	Z7.280.2227.0	10	IVB WK 2,5-2	Z7.280.2227.0	10
	3 pole	IVB WK 2,5-3	Z7.280.2327.0	10	IVB WK 2,5-3	Z7.280.2327.0	10
	up to 12 pole	IVB WK 2,5-12	Z7.280.3227.0	10	IVB WK 2,5-12	Z7.280.3227.0	10
Connecting rail, tin plated	L = 0.4 m		05.561.4125.0	1		05.561.4125.0	1
Single cover for jumper bar with marking facility		ADVB 2,5 GELB	04.326.2053.0		ADVB 2,5 GELB	04.326.2053.0	
Cover strip for header	24 pole		04.343.9056.0			04.343.9056.0	
Cover strip for header with warning symbol			04.343.9156.0			04.343.9156.0	
Insulating plate		TS 2,5 GELB	07.311.2053.0		TS 2,5 GELB	07.311.2053.0	
Coding part (branch)			05.561.0053.0			05.561.0053.0	100
Sealing end	10 pole						
See page 394 for labelling systems							

wiecon

Indicator: R = 10 K; 0.5 W
LED colour: red

¹⁾ determined by LED at terminal

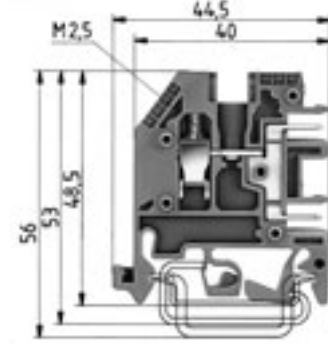
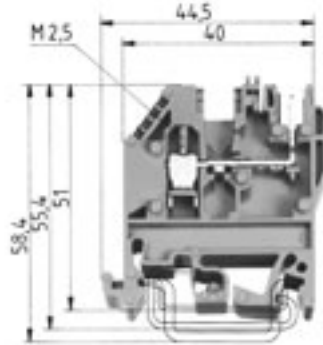
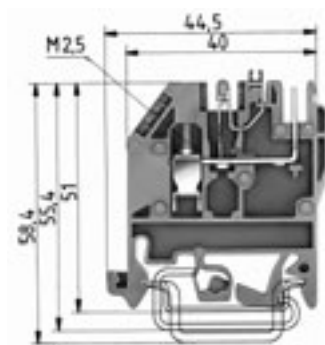

WK 2.5 U / 8113 S/V / LED 50

finely stranded single core	V	A
0.5 – 2.5 mm ² 0.5 – 4 mm ²	¹⁾	12
No. 22 – 12 AWG	300 V	15
No. 24 – 12 AWG	50 V	15
5 mm		9 mm



WK 2.5 U / 8113 S/V /VK

finely stranded single core	V	A
0.5 – 2.5 mm ² 0.5 – 4 mm ²	250 V/4 kV/3	12
No. 22 – 12 AWG	300 V	15
No. 24 – 12 AWG	300 V	15
5 mm		9 mm



WK 2.5 U / 8113 S/H

finely stranded single core	V	A
0.5 – 2.5 mm ² 0.5 – 4 mm ²	250 V/4 kV/3	12
No. 22 – 12 AWG	300 V	20
No. 24 – 12 AWG	300 V	15
5 mm		9 mm



Type	Part No.	Box Qty	Type	Part No.	Box Qty	Type	Part No.	Box Qty
WK 2.5 U/8113 S/V/LED 50***)	57.503.2855.0	50	WK 2.5 U/8113 S/V/VK***)	57.503.3055.6		WK 2.5 U/8113 S/H***)	57.503.2055.0	100
AP 2.5 U/8113 S/V ***)	07.312.1555.0	10	AP 2.5 U/8113 ***)	07.312.4655.0	10	AP 2.5 U/8113 S/H ***)	07.311.9855.0	10
AP 2.5 U/8113 ***)	07.312.4655.0	10	AP 2.5 U/8113 S/V BL***)	07.312.1555.0	10			
ZP 2.5 U/8113 S/V	07.312.1655.0	10	ZP 2.5 U/8113 S/V	07.312.1655.0	10			
			ZP 2.5 U/8113 S/V BL	07.312.1655.6	10			
IVB WK 2,5-2	Z7.280.2227.0	10	IVB WK 2,5-2	Z7.280.2227.0	10	IVB WK 2,5-2	Z7.280.2227.0	10
IVB WK 2,5-3	Z7.280.2327.0	10	IVB WK 2,5-3	Z7.280.2327.0	10	IVB WK 2,5-3	Z7.280.2327.0	10
IVB WK 2,5-12	Z7.280.3227.0	10	IVB WK 2,5-12	Z7.280.3227.0	10	IVB WK 2,5-12	Z7.280.3227.0	10
	05.561.4125.0	1		05.561.4125.0	1		05.561.4125.0	1
ADVB 2,5 GELB	04.326.2053.0		ADVB 2,5 GELB	04.326.2053.0		ADVB 2,5 GELB	04.326.2053.0	
	04.343.9056.0			04.343.9056.0			04.343.9056.0	
	04.343.9156.0			04.343.9156.0			04.343.9156.0	
TS 2,5 GELB	07.311.2053.0		TS 2,5 GELB	07.311.2053.0		TS 2,5 GELB	07.311.2053.0	
	05.561.0053.0	100		05.561.0053.0	100		05.584.0053.0	100
							05.576.5853.0	25

Modular terminals, rising cage clamp with header for pluggable PCB terminals

wiecon PCB

for PCB terminals:

- Type 8113 B
- Type 8113 BFK
- Type 8313 B
- Type 8113 B/VL
- Type 8113 B/VR
- Type 8113 B/Top

Indicator: R = 4.7 K; 0.5 W
LED colour: red

¹⁾ determined by LED in terminal

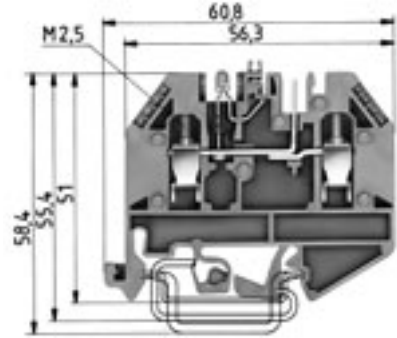
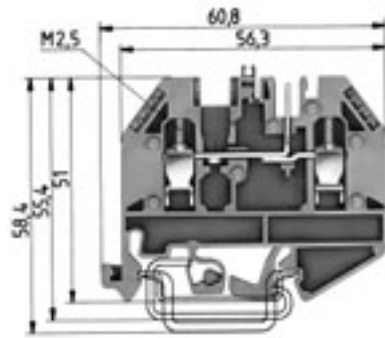

The items marked with ***) have insulating housing in accordance with UL 94-V0 (flammability class)

WK 2.5 U /D/ 8113 S/V

finely stranded single core V A
0.5 – 2.5 mm² 0.5 – 4 mm² 250 V/4 kV/3 12
No. 22 – 12 AWG 300 V 15
No. 24 – 12 AWG 300 V 15
5 mm 9 mm



WK 2.5 U /D/ 8113 S/V / LED 25

finely stranded single core V A
0.5 – 2.5 mm² 0.5 – 4 mm² ¹⁾ 12
No. 22 – 12 AWG 300 V 15
No. 24 – 12 AWG 25 V 15
5 mm 9 mm



EN 60 947-7-1/DIN VDE 0611 T1

UL Data

CSA Data

Width

stripping length

Approvals

		Type	Part No.	Box Qty	Type	Part No.	Box Qty
Modular terminal	Colour: grey	WK 2,5 U/D/8113 S/V...***)	57.503.2155.0	50			
Modular terminal with LED 25 V	Colour: grey				WK 2,5 U/D/8113 S/V/LED 25***)	57.503.2255.0	50
Modular terminal with LED 50 V	Colour: grey						
Supply terminal	Colour: blue						
Modular terminal with header							
PCB terminals type 8113 see page 297							
Accessories							
Mounting rail 35 DIN rail 7.5 mm high	L = 2 m						
Mounting rail 35 DIN rail 15 mm high	L = 2 m						
Mounting rail 32 G-rail	L = 2 m						
End clamp with U-foot	10 mm wide						
End clamp TS 35 with screw	8 mm wide						
End clamp TS 32 with screw	7.5 mm wide						
End plate 2.5 mm thick	Colour: grey	AP 2,5 U/D/8113 S/V ***)	07.311.9055.0	10	AP 2,5 U/D/8113 S/V***)	07.311.9055.0	10
End plate 2.5 mm thick	Colour: blue						
Intermediate plate 2.5 mm thick	Colour: grey	ZP 2,5 U/D/8113 S/V	07.311.9155.0	10	ZP 2,5 U/D/8113 S/V	07.311.9155.0	10
Intermediate plate 2.5 mm thick	Colour: blue						
(for use of PCB terminals with 7.5 mm)							
Jumper bar with screws, E-Cu	insulated						
	2 pole	IVB WK 2,5-2	Z7.280.2227.0	10	IVB WK 2,5-2	Z7.280.2227.0	10
	3 pole	IVB WK 2,5-3	Z7.280.2327.0	10	IVB WK 2,5-3	Z7.280.2327.0	10
	up to 12 pole	IVB WK 2,5-12	Z7.280.3227.0	10	IVB WK 2,5-12	Z7.280.3227.0	10
Connecting rail, tin plated	L = 0.4 m		05.561.4125.0	1		05.561.4125.0	1
Cover strips for LED (transparent)		ADVB 5/10 P	04.342.3556.8	10	ADVB 5/10 P	04.342.3556.8	10
Single cover for jumper bar with marking facility		ADVB 2,5 GELB	04.326.2053.8	10	ADVB 2,5 GELB	04.326.2053.8	10
Cover strip for header	24 pole		04.343.9056.8	10		04.343.9056.8	10
Cover strip for header with warning symbol	24 pole		04.343.9156.8	10		04.343.9156.8	10
Insulating plate		TS 2,5 GELB	07.311.2053.8	10	TS 2,5 GELB	07.311.2053.8	10
Coding part (branch)			05.561.0053.0	100		05.561.0053.0	100
See page 394 for labelling systems							

wiecon

Indicator: R = 10 K; 0.5 W
LED colour: red

¹⁾ determined by LED int terminal

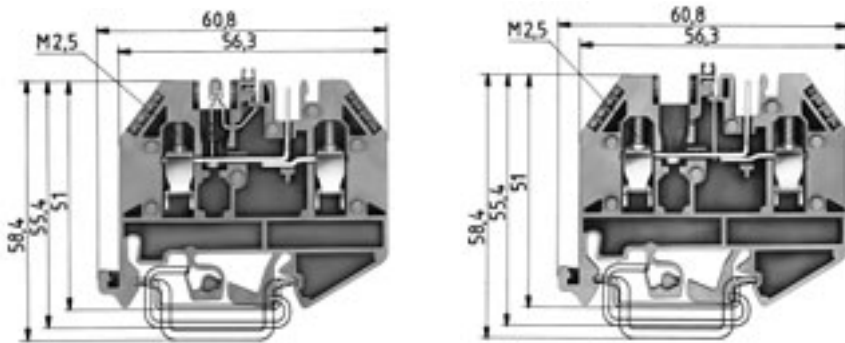

WK 2.5 U /D/ 8113 S/V / LED 50

finely stranded single core	V	A
0.5 – 2.5 mm ² 0.5 – 4 mm ²	¹⁾	12
No. 22 – 12 AWG	300 V	15
No. 24 – 12 AWG	50 V	15
5 mm		9 mm



WK 2.5 U /D/ 8113 S/V /VK

finely stranded single core	V	A
0.5 – 2.5 mm ² 0.5 – 4 mm ²	250 V/4 kV/3	12
No. 22 – 12 AWG	300 V	15
No. 24 – 12 AWG	300 V	15
5 mm		9 mm



Type	Part No.	Box Qty	Type	Part No.	Box Qty
WK 2,5 U/D/8113 S/V/LED 50***)	57.503.2355.0	50	WK 2,5 U/D/8113 S/V/VK***)	57.503.2555.6	50
AP 2,5 U/D/8113 S/V ***)	07.311.9055.0	10	AP 2,5 U/D/8113 S/V BL***)	07.311.9055.6	10
ZP 2,5 U/D/8113 S/V	07.311.9155.0	10	ZP 2,5 U/D/8113 S/V BL	07.311.9155.6	10
IVB WK 2,5-2	Z7.280.2227.0	10	IVB WK 2,5-2	Z7.280.2227.0	10
IVB WK 2,5-3	Z7.280.2327.0	10	IVB WK 2,5-3	Z7.280.2327.0	10
IVB WK 2,5-12	Z7.280.3227.0	10	IVB WK 2,5-12	Z7.280.3227.0	10
	05.561.4125.0	1		05.561.4125.0	1
ADVB 5/10 P	04.342.3556.8	10	ADVB 5/10 P	04.342.3556.8	10
ADVB 2,5 GELB	04.326.2053.8	10	ADVB 2,5 GELB	04.326.2053.8	10
	04.343.9056.8	10		04.343.9056.8	10
	04.343.9156.8	10		04.343.9156.8	10
TS 2,5 GELB	07.311.2053.8	10	TS 2,5 GELB	07.311.2053.8	10
	05.561.0053.0	100		05.561.0053.0	100

Two part PCB terminals with pin strip headers

wiecon PCB

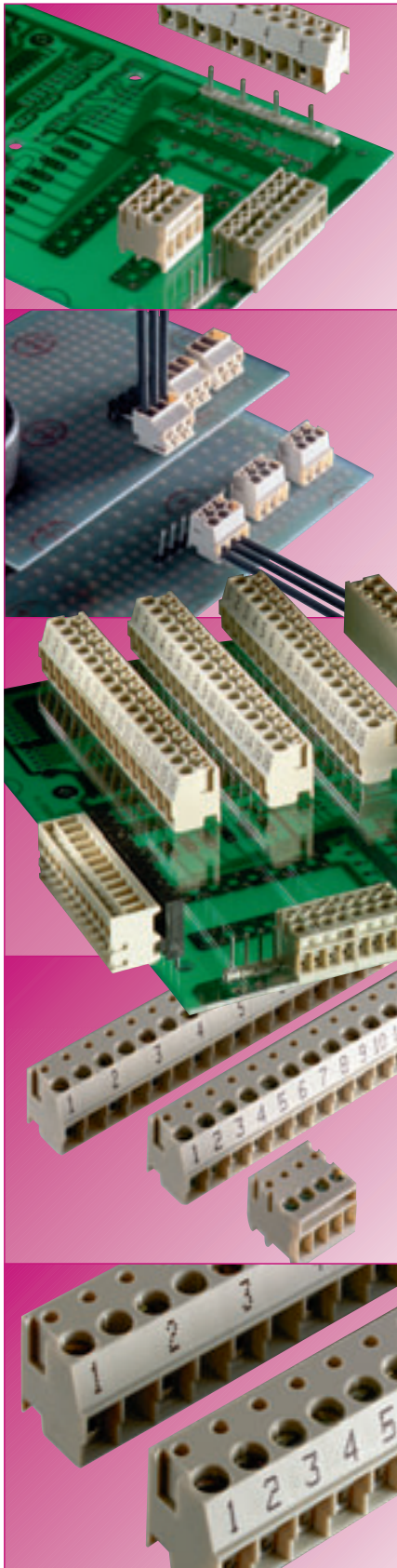

Indirect connection describes the method used to connect an external conductor to a PCB via a pin header and terminal connector

System features

- screw connection is easy to operate
- plug in system easy to service
- easily detachable connection
- number of poles 2 – 24
- clear straight forward interconnection
- horizontal and vertical configurations that can be individually matched to the relevant application
- terminal clamping part with wire protection

Type range

- pitch (3.5/7/5/10) mm
- 2 – 24 pole
- pin strips with straight or angled solder pins
- pin diameters 0.8 mm, 1 mm and 1.3 mm

Marking

- by means of inkjet printer directly onto the terminal using indelible ink
- clear pole marking which is easy to read
- special marking is possible on request
- economical marking directly into the terminal

Abbreviations for plastic marking material:

- PA 66/6 = Polyamide 66/6
- PC = Polycarbonate
- PBT = Polybutylenterephthalate

Materials

Insulating housing:

- high quality polyamide used because of its excellent electrical, mechanical and chemical properties (see **facts** & DATA section)

Metal components:

- made from special alloys and/or special surface treatments
- clamp: nickel plated brass
- clamping screw: galvanised and chromated steel
- header contact for type 8142 and ST 29: tinned bronze
header contact for type 8543: tinned brass
- wire protection: tinned bronze
- minimum contact resistance
- with high corrosion protection
- secure, dynamic clamping function

Pin headers:

- Insulating parts: made of high quality Polyamide 66/6
- Metal components: contact pin, Ms tinned
- glass filled for additional reinforcement

Note:

The conductor size and connecting voltage current capacity relate to unprepared conductors without ferrules.

The rated current specified corresponds to the maximum load of PCB terminal and the size of the connected conductor.

The rated voltage is specified in accordance with DIN VDE 0110 Part 1 (IEC 60 664-1) – Insulation regulations for electrical equipment in low voltage installations and refers to the received condition of the PCB terminals.

When fitting PCB terminals to the PCB, the appropriate terminal should be selected with consideration given to the relevant electrical and physical properties suitable to the application. Also, attention should be paid to circuit board tracking, creepage and clearances as well as distances between individual conductor and solder pads.

In addition, the various forms of environmental pollutants and their degree of influence can effect the performance of a piece of equipment. A system approach is therefore required to ensure that the electrical and other parameters of the PCB terminal match that governed by the functionality of the printed circuit board design.

wiecon

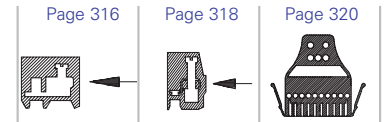

		Page 316	Page 318	Page 320
Type		8543	8142	ST 29
Pitch	mm	3.50/7.00	5.00/10.00	5.08
Cross section	mm²	1	2.5	1.5
Pole		2 – 24	2 – 24	10



Two part PCB terminal, pitch 3.50/7.00 mm

wiecon PCB

Rated cross section
1.0 mm²

Rated current:
6 A

Wire range:
0.14 – 1.5 mm² single core/
0.14 – 1.0 mm² finely stranded

160 V/2.5 kV/3 – overvoltage category III
250 V/2.5 kV/2 – overvoltage category II
*690 V/2.5 kV/1 – overvoltage category I

* max. 600 V for non earthed systems or expected overvoltage ≤
3kV for L ≥ 2.0 mm and ≤ 2.5 kV for 2.0 mm > L ≥ 1.5 mm

Pitch 3.50 mm

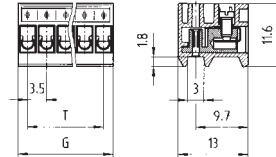

Pitch 3.50 mm

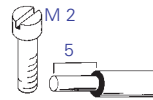
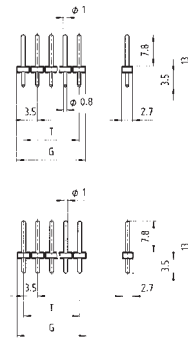

Colour: grey Solder pin Ø 0.8 mm Drill hole: Ø 1.0 mm
Colour: black Solder pin Ø 1.0 mm Drill hole: Ø 1.3 mm

Type 8543

Connection at 90° to conductor

PCB header

Connection vertical to PCB

Rated voltages VDE 0110 (Pitch 3.5 mm)

UL Data

CSA Data

Approvals

No. 22 – 16 AWG

300 V

10 A

No. 22 – 16 AWG

300 V

10 A



Box Qty	G	T	Pole	Part No.	Part No.	Part No.	Part No.
Pitch 3.50 mm							
				unmarked	marked	Colour: grey	Colour: black
100	7.0	3.5	2	25.602.5253.0	25.600.5253.0	Z5.531.0225.0	Z5.531.3225.0
100	10.5	7.0	3	25.602.5353.0	25.600.5353.0	Z5.531.0325.0	Z5.531.3325.0
50	14.0	10.5	4	25.602.5453.0	25.600.5453.0	Z5.531.0425.0	Z5.531.3425.0
50	17.5	14.0	5	25.602.5553.0	25.600.5553.0	Z5.531.0525.0	Z5.531.3525.0
50	21.0	17.5	6	25.602.5653.0	25.600.5653.0	Z5.531.0625.0	Z5.531.3625.0
50	24.5	21.0	7	25.602.5753.0	25.600.5753.0	Z5.531.0725.0	Z5.531.3725.0
50	28.0	24.5	8	25.602.5853.0	25.600.5853.0	Z5.531.0825.0	Z5.531.3825.0
50	31.5	28.0	9	25.602.5953.0	25.600.5953.0	Z5.531.0925.0	Z5.531.3925.0
50	35.0	31.5	10	25.602.6053.0	25.600.6053.0	Z5.531.1025.0	Z5.531.4025.0
50	38.5	35.0	11	25.602.6153.0	25.600.6153.0	Z5.531.1125.0	Z5.531.4125.0
50	42.0	38.5	12	25.602.6253.0	25.600.6253.0	Z5.531.1225.0	Z5.531.4225.0
50	45.5	42.0	13	25.602.6353.0	25.600.6353.0	Z5.531.1325.0	Z5.531.4325.0
50	49.0	45.5	14	25.602.6453.0	25.600.6453.0	Z5.531.1425.0	Z5.531.4425.0
50	52.5	49.0	15	25.602.6553.0	25.600.6553.0	Z5.531.1525.0	Z5.531.4525.0
50	56.0	52.5	16	25.602.6653.0	25.600.6653.0	Z5.531.1625.0	Z5.531.4625.0
1 to 24 pole on request							
Pitch 7.00 mm on request							
Rated voltages (Pitch 7 mm): VDE 0110							
400 V/6 kV/3 – overvoltage category III							
690 V/6 kV/2 – overvoltage category II							
1000 V/6 kV/1 – overvoltage category I							
Materials							
PCB terminals							
Insulating component: PC grey, UL 94-V0							
Clamping parts and contact spring: tin plated brass							
Clamping screw: galvanised steel							
Wire protection: tin plated bronze							
Header							
Insulating component: reinforced PA 66/6 grey or black UL 94-V0							
Contact pin: tin plated brass							

wiecon

Pitch 3.50 mm

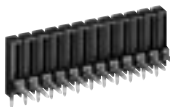
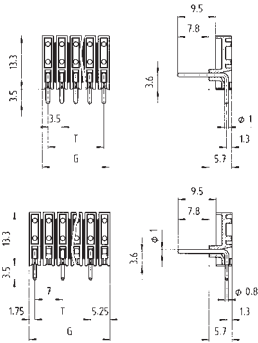

Colour: black
Solder pin Ø 0.8 mm
Drill hole: Ø 1.0 mm

Colour: black
Solder pin Ø 1.0 mm
Drill hole: Ø 1.3 mm

PCB header

Connection horizontal to PCB



Part No.	Part No.
Colour: black	Colour: black
Z5.532.0225.0	Z5.532.3225.0
Z5.532.0325.0	Z5.532.3325.0
Z5.532.0425.0	Z5.532.3425.0
Z5.532.0525.0	Z5.532.3525.0
Z5.532.0625.0	Z5.532.3625.0
Z5.532.0725.0	Z5.532.3725.0
Z5.532.0825.0	Z5.532.3825.0
Z5.532.0925.0	Z5.532.3925.0
Z5.532.1025.0	Z5.532.4025.0
Z5.532.1125.0	Z5.532.4125.0
Z5.532.1225.0	Z5.532.4225.0
Z5.532.1325.0	Z5.532.4325.0
Z5.532.1425.0	Z5.532.4425.0
Z5.532.1525.0	Z5.532.4525.0
Z5.532.1625.0	Z5.532.4625.0

Two part PCB terminal, pitch 5.00/10.00 mm

wiecon PCB

Rated cross section
2.5 mm²

Rated current:
8 A

Wire range:
0.14 – 4.0 mm² single core/
0.14 – 2.5 mm² finely stranded

200 V/4 kV/3 – overvoltage category III
250 V/4 kV/2 – overvoltage category II
1000 V/4 kV/1 – overvoltage category I

Pitch 5.00 mm

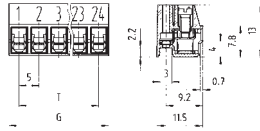

Pitch 10.00 mm

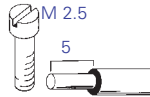
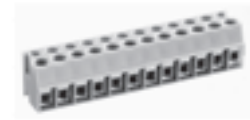
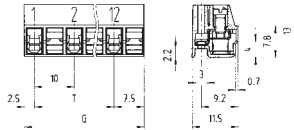

Pitch 5.00 mm

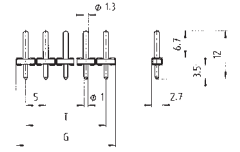

Pitch 10.00 mm

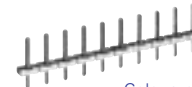
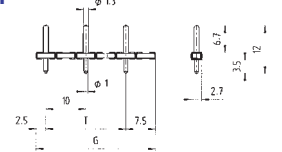

Colour: grey
Solder pin Ø 1.0 mm
Drill hole: Ø 1.3 mm

Colour: black
Solder pin Ø 1.3 mm
Drill hole: Ø 1.6 mm

Type 8142

Connection at 90° to conductor

No. 22 – 12 AWG 300 V 15 A
No. 22 – 12 AWG 300 V 15 A



PCB header

Connection vertical to PCB



Rated voltages VDE 0110 (Pitch 5 mm)

UL Data

CSA Data

Approvals

Box Qty	G	T	Pole	Part No.	Part No.	Part No.	Part No.
Pitch 5.00 mm				unmarked	marked	Colour: grey	Colour: black
100	10	5	2	25.602.2253.0	25.600.2253.0	Z5.530.0225.0	Z5.530.3225.0
100	15	10	3	25.602.2353.0	25.600.2353.0	Z5.530.0325.0	Z5.530.3325.0
50	20	15	4	25.602.2453.0	25.600.2453.0	Z5.530.0425.0	Z5.530.3425.0
50	25	20	5	25.602.2553.0	25.600.2553.0	Z5.530.0525.0	Z5.530.3525.0
50	30	25	6	25.602.2653.0	25.600.2653.0	Z5.530.0625.0	Z5.530.3625.0
50	35	30	7	25.602.2753.0	25.600.2753.0	Z5.530.0725.0	Z5.530.3725.0
50	40	35	8	25.602.2853.0	25.600.2853.0	Z5.530.0825.0	Z5.530.3825.0
50	45	40	9	25.602.2953.0	25.600.2953.0	Z5.530.0925.0	Z5.530.3925.0
50	50	45	10	25.602.3053.0	25.600.3053.0	Z5.530.1025.0	Z5.530.4025.0
50	55	50	11	25.602.3153.0	25.600.3153.0	Z5.530.1125.0	Z5.530.4125.0
50	60	55	12	25.602.3253.0	25.600.3253.0	Z5.530.1225.0	Z5.530.4225.0
50	65	60	13	25.602.3353.0	25.600.3353.0	Z5.530.1325.0	Z5.530.4325.0
50	70	65	14	25.602.3453.0	25.600.3453.0	Z5.530.1425.0	Z5.530.4425.0
50	75	70	15	25.602.3553.0	25.600.3553.0	Z5.530.1525.0	Z5.530.4525.0
50	80	75	16	25.602.3653.0	25.600.3653.0	Z5.530.1625.0	Z5.530.4625.0
1 to 24 pole on request							
Pitch 10.00 mm				unmarked	marked		
50	20	10	2	25.603.1253.0	25.601.1253.0	Z5.530.6225.0	Z5.530.8225.0
50	30	20	3	25.603.1353.0	25.601.1353.0	Z5.530.6325.0	Z5.530.8325.0
50	40	30	4	25.603.1453.0	25.601.1453.0	Z5.530.6425.0	Z5.530.8425.0
50	50	40	5	25.603.1553.0	25.601.1553.0	Z5.530.6525.0	Z5.530.8525.0
50	60	50	6	25.603.1653.0	25.601.1653.0	Z5.530.6625.0	Z5.530.8625.0
50	70	60	7	25.603.1753.0	25.601.1753.0	Z5.530.6725.0	Z5.530.8725.0
50	80	70	8	25.603.1853.0	25.601.1853.0	Z5.530.6825.0	Z5.530.8825.0
9 to 12 pole on request							
Rated voltages (Pitch 10.00 mm): VDE 0110				Materials			
500 V/8 kV/3 – overvoltage category III				PCB terminals			
800 V/8 kV/2 – overvoltage category II				Insulating component: PC grey, UL 94-V0			
1000 V/8 kV/1 – overvoltage category I				Clamping parts: nickel plated brass			
				Clamping screw: galvanised steel			
				Contact spring: tin plated bronze			
				Header			
				Insulating component: reinforced PA 66/6			
				grey or black, UL 94-V0			
				Contact pin: tin plated brass			

wiecon

Accessories

Pitch 5.00 mm

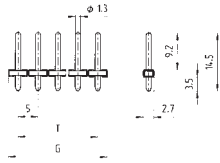

Pitch 10.00 mm

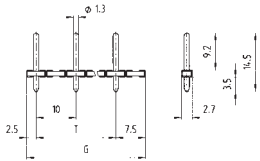

Colour: black Solder pin Ø 1.0 mm Drill hole: Ø 1.3 mm
 Colour: black Solder pin Ø 1.3 mm Drill hole: Ø 1.6 mm

PCB header

Connection horizontal to PCB



Part No.	Part No.	Part No.	Box Qty	Part No.	Box Qty
Colour: black	Colour: black	Mounting bracket			
Z5.540.0225.0	Z5.540.3225.0	Insulating component PA 66/6 grey, M 3 screw, galvanised steel		Z5.523.7653.0	100
Z5.540.0325.0	Z5.540.3325.0				
Z5.540.0425.0	Z5.540.3425.0				
Z5.540.0525.0	Z5.540.3525.0	Coding branch		Colour white	05.561.9453.0 25
Z5.540.0625.0	Z5.540.3625.0	Colour white	05.561.9453.0 25	Colour orange	05.561.9453.5 25
Z5.540.0725.0	Z5.540.3725.0	Colour orange	05.561.9453.5 25		
Z5.540.0825.0	Z5.540.3825.0				
Z5.540.0925.0	Z5.540.3925.0				
Z5.540.1025.0	Z5.540.4025.0				
Z5.540.1125.0	Z5.540.4125.0				
Z5.540.1225.0	Z5.540.4225.0				
Z5.540.1325.0	Z5.540.4325.0				
Z5.540.1425.0	Z5.540.4425.0				
Z5.540.1525.0	Z5.540.4525.0				
Z5.540.1625.0	Z5.540.4625.0				
Z5.540.6225.0	Z5.540.8225.0				
Z5.540.6325.0	Z5.540.8325.0				
Z5.540.6425.0	Z5.540.8425.0				
Z5.540.6525.0	Z5.540.8525.0				
Z5.540.6625.0	Z5.540.8625.0				
Z5.540.6725.0	Z5.540.8725.0				
Z5.540.6825.0	Z5.540.8825.0				

vertical mounting position

horizontal mounting position

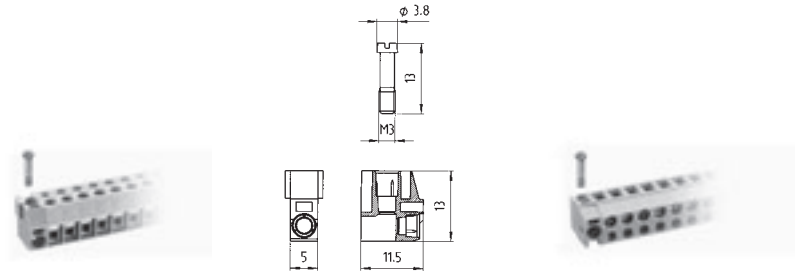

drilling plan for mounting bracket in vertical mounting position

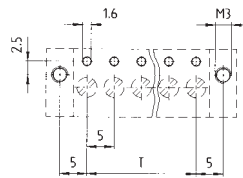

drilling plan for mounting bracket in horizontal mounting position

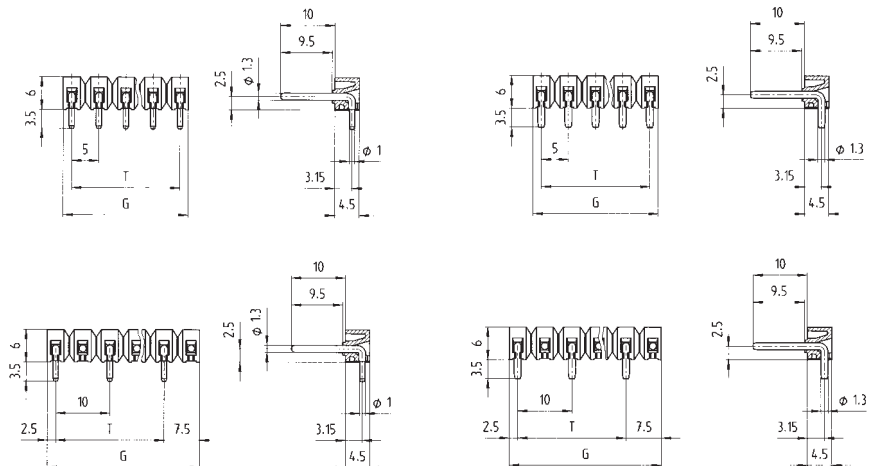
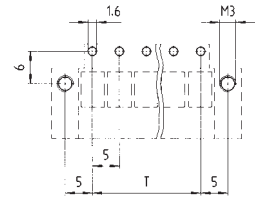

**Two part PCB terminal.
pitch 5.08 mm**

wiecon PCB

cable size
1.5 mm²

Rated cross section
1.5 mm²

Rated current:
10 A

Wire range:
0.14 – 2.5 mm² single core/
0.14 – 1.5 mm² finely stranded

200 V/4 kV/3 – overvoltage category III
250 V/4 kV/2 – overvoltage category II
1000 V/4 kV/1 – overvoltage category I

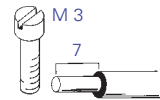

Solder pin Ø 1.3 mm
Drill hole Ø 1.6 mm

Statement of Conformity/CH

**Top connector, 10 pole
Type ST 29/10 BC**

Connection at 90° to conductor

1.5 mm ²	250 V	10 A
No. 22 – 14 AWG	300 V	5 A
No. 22 – 14 AWG	300 V	5 A



PCB header

Connection vertical to PCB

250 V	10 A
(if all terminals carry current)	10 A



Rated voltages VDE 0110
EN 60 998-1, EN 60 998-2-1
UL Data
CSA Data
Approvals

Pole	Type	Part No.	Box Qty	Type	Part No.	Box Qty
Pitch 5.08 mm						
10	ST 29/10 BC	93.101.2053.0	50		Z5.599.9025.0	50

Materials
PCB terminals
Insulating component: PA 66/6 grey, UL 94-V-2
Clamping parts: nickel plated brass
Clamping screw: galvanised steel
Contact spring: tin plated bronze

Header
Insulating component: reinforced PBT grey, UL 94-V0
Contact pin: tin plated brass

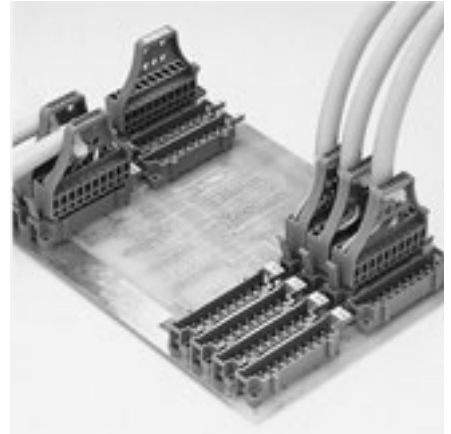

Top connector

A variation of the top system is a header which can be soldered into PCB's. The pin spacing is 5.08 mm.

Two holes are provided for fixing the header and there are facilities for:

- strain relief
- locking
- marking

Dovetail guides enable several headers to be snapped on and only the outside plug connectors in this grouping need to be mechanically fixed to the PCB. In order to guarantee the stability required for the PCB's it is recommended that no more than four headers are included in a group.

Terminal block, header, the relevant plug or a plug in module each have eight locators for coding pins.

Coding both parts is a reliable way of preventing the top connection system mating incorrectly.

Accessories	Type	Part No.	Box Qty
Coding parts, 10 pieces on branch		05.599.8053.0	100
Marking tag, unmarked	9705 A	04.242.0850.0	500
marked	9705 AB	04.842.0850.0	500
<p>Coding L = PCB terminal S = header</p> <p>1. combination S L L L L L L S</p> <p>2. combination S L L L L L S L</p> <p>3. combination S L L L L S L L</p> <p>4. combination S L L L S L L L</p> <p>5. combination S L L S L L L L</p> <p>6. combination S L S L L L L L</p> <p>7. combination S S L L L L L L</p> <p>8. combination L S L L L L L S</p> <p>9. combination L S L L L L S L</p> <p>10. combination L S L L L S L L</p> <p>11. combination L S L L S L L L</p> <p>12. combination L S L S L L L L</p> <p>13. combination L S S L L L L L</p> <p>14. combination L L S L L L L S</p> <p>etc.</p>			

Two part PCB spring loaded terminal, Type 8520 B

wiecon PCB

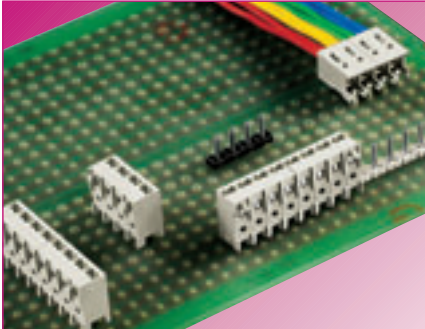

A PCB terminal with a spring loaded connection has the advantage that contact to the printed circuit board can be established quickly and economically. Wieland Electric had designed its new PCB terminal type 8520 with this in mind.

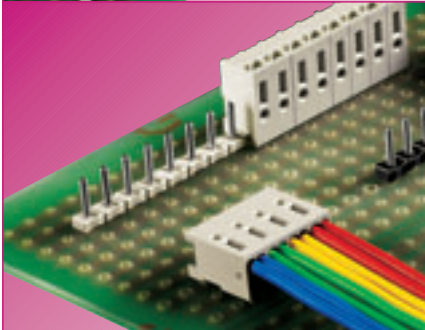

The main areas of use for this type of PCB terminal are in applications where high volumes require an efficient and cost effective operation.

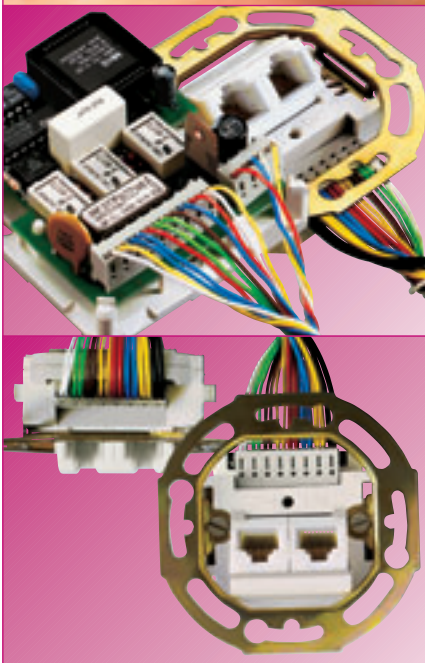

System features:

- no screw fixing
- minimised wiring time
- consistency of clamping force
- resistant to vibrations and shocks
- maintenance free

Several versions of type 8520 can service a variety of applications. They are available as a two part header terminal connector and as a soldered design with both straight and angled soldering pins. The rated cross section is 0.5 mm² for single core. The conductor can therefore be plugged in easily without having to operate the header clamping spring as part of the same operation. The pitch is 3.5 mm (7.00mm on request). The pole numbers range from 2 to 16 poles.



wiecon

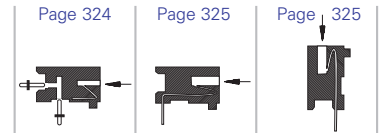

		Page 324	Page 325	Page 325
Type		8520 B	8520 BL/...W	8520 BL/...G
Pitch	mm	3.50/7.00	3.50/7.00	3.50/7.00
Cross section	mm²	0.25 – 0.50	0.25 – 0.50	0.25 – 0.50
Pole		2 – 16	2 – 16	2 – 16



Two part PCB terminal with spring loaded connection, Type 8520, pitch 3.50/7.00 mm, 2 x 0.5 mm²

wiecon PCB

Rated cross section
0.5 mm²

Rated current:
4 A

Wire range:
0.25 – 0.5 mm² single core
2 connections per pole

160 V/2.5 kV/3 – overvoltage category III
250 V/2.5 kV/2 – overvoltage category II
*690 V/2.5 kV/1 – overvoltage category I

Pitch 3.50 mm

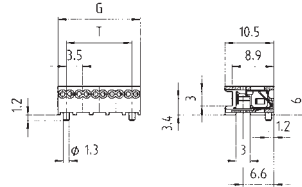

Pitch 3.50 mm

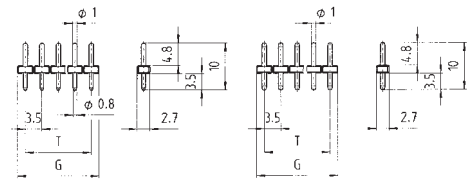

* max. 600 V for non earthed systems or expected overvoltage
≤ 3 kV for L ≥ 2.0 mm and ≤ 2.5 kV for 2.0 mm > L ≥ 1.5 mm

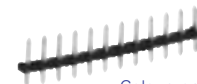
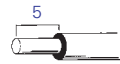

Colour: grey
Solder pin Ø 0.8 mm
Drill hole: Ø 1.0 mm

Colour: black
Solder pin Ø 1.0 mm
Drill hole: Ø 1.2 mm

Type 8520 B

Connection horizontal and vertical

PCB header 8520 S

Connection vertical to PCB

Rated voltages VDE 0110 (Pitch 3.5 mm)

UL Data

CSA Data

Approvals in preparation

No. 24 – 20 AWG 125 V 4 A
No. 24 – 20 AWG 150 V 4 A

Box Qty	G	T	Pole	Part No. unmarked	Part No. marked	Part No. Colour: grey	Part No. Colour: black
Pitch 3.50 mm							
1000	7.0	3.5	2	25.470.0253.0	25.470.3253.0	Z5.535.0225.0	Z5.535.3225.0
1000	10.5	7.0	3	25.470.0353.0	25.470.3353.0	Z5.535.0325.0	Z5.535.3325.0
1000	14.0	10.5	4	25.470.0453.0	25.470.3453.0	Z5.535.0425.0	Z5.535.3425.0
500	17.5	14.0	5	25.470.0553.0	25.470.3553.0	Z5.535.0525.0	Z5.535.3525.0
500	21.0	17.5	6	25.470.0653.0	25.470.3653.0	Z5.535.0625.0	Z5.535.3625.0
500	24.5	21.0	7	25.470.0753.0	25.470.3753.0	Z5.535.0725.0	Z5.535.3725.0
500	28.0	24.5	8	25.470.0853.0	25.470.3853.0	Z5.535.0825.0	Z5.535.3825.0
250	31.5	28.0	9	25.470.0953.0	25.470.3953.0	Z5.535.0925.0	Z5.535.3925.0
250	35.0	31.5	10	25.470.1053.0	25.470.4053.0	Z5.535.1025.0	Z5.535.4025.0
250	38.5	35.0	11	25.470.1153.0	25.470.4153.0	Z5.535.1125.0	Z5.535.4125.0
250	42.0	38.5	12	25.470.1253.0	25.470.4253.0	Z5.535.1225.0	Z5.535.4225.0
250	45.5	42.0	13	25.470.1353.0	25.470.4353.0	Z5.535.1325.0	Z5.535.4325.0
250	49.0	45.5	14	25.470.1453.0	25.470.4453.0	Z5.535.1425.0	Z5.535.4425.0
250	52.5	49.0	15	25.470.1553.0	25.470.4553.0	Z5.535.1525.0	Z5.535.4525.0
250	56.0	52.5	16	25.470.1653.0	25.470.4653.0	Z5.535.1625.0	Z5.535.4625.0
Pitch 7.00 mm on request							
Rated voltages (Pitch 7.00 mm): VDE 0110							
400 V/6 kV/3 – overvoltage category III							
690 V/6 kV/2 – overvoltage category II							
1000 V/6 kV/1 – overvoltage category I							
Materials							
PCB terminals							
Insulating component: PA 66/6. UL 94-V0							
Clamping spring: special copper alloy, tin plated							
Header							
Insulating component: reinforced PA 66/6							
grey or black, UL 94-V0							
Contact pin: tin plated brass							

PCB terminal with spring loaded connection, Type 8520, pitch 3.50/7.00 mm, 2 x 0.5 mm²

Rated cross section
0.5 mm²

Rated current:
4 A

Wire range:
0.25 – 0.5 mm² single core
2 connections per pole

160 V/2.5 kV/3 – overvoltage category III
250 V/2.5 kV/2 – overvoltage category II
*690 V/2.5 kV/1 – overvoltage category I

* max. 600 V for non earthed systems or expected overvoltage
≤ 3 kV for L ≥ 2.0 mm and ≤ 2.5 kV for 2.0 mm > L ≥ 1.5 mm

Pitch 3.50 mm

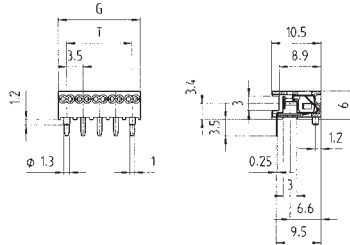

Pitch 3.50 mm

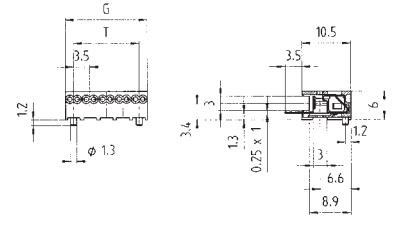

Solder pin 0.25 x 1.0 mm
Drill hole Ø 1.1 mm

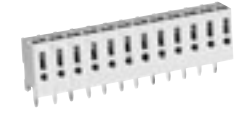
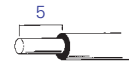

Type 8520 BL/...W

Conductor horizontal to PCB

Type 8520 BL/...G

Conductor vertical to PCB

Rated voltages VDE 0110

UL Data

CSA Data

Approvals in preparation

No. 24 – 20 AWG

125 V

4 A

No. 24 – 20 AWG

125 V

4 A

No. 24 – 20 AWG

150 V

4 A

No. 24 – 20 AWG

150 V

4 A

Box Qty	G	T	Pole	Part No.	Part No.	Part No.	Part No.
Pitch 3.50 mm				unmarked	marked	unmarked	marked
1000	7.0	3.5	2	25.471.0253.0	25.471.3253.0	25.472.0253.0	25.472.3253.0
1000	10.5	7.0	3	25.471.0353.0	25.471.3353.0	25.472.0353.0	25.472.3353.0
1000	14.0	10.5	4	25.471.0453.0	25.471.3453.0	25.472.0453.0	25.472.3453.0
500	17.5	14.0	5	25.471.0553.0	25.471.3553.0	25.472.0553.0	25.472.3553.0
500	21.0	17.5	6	25.471.0653.0	25.471.3653.0	25.472.0653.0	25.472.3653.0
500	24.5	21.0	7	25.471.0753.0	25.471.3753.0	25.472.0753.0	25.472.3753.0
500	28.0	24.5	8	25.471.0853.0	25.471.3853.0	25.472.0853.0	25.472.3853.0
250	31.5	28.0	9	25.471.0953.0	25.471.3953.0	25.472.0953.0	25.472.3953.0
250	35.0	31.5	10	25.471.1053.0	25.471.4053.0	25.472.1053.0	25.472.4053.0
250	38.5	35.0	11	25.471.1153.0	25.471.4153.0	25.472.1153.0	25.472.4153.0
250	42.0	38.5	12	25.471.1253.0	25.471.4253.0	25.472.1253.0	25.472.4253.0
250	45.5	42.0	13	25.471.1353.0	25.471.4353.0	25.472.1353.0	25.472.4353.0
250	49.0	45.5	14	25.471.1453.0	25.471.4453.0	25.472.1453.0	25.472.4453.0
250	52.5	49.0	15	25.471.1553.0	25.471.4553.0	25.472.1553.0	25.472.4553.0
250	56.0	52.5	16	25.471.1653.0	25.471.4653.0	25.472.1653.0	25.472.4653.0
Pitch 7.00 mm on request							
Rated voltages (Pitch 7.00 mm): VDE 0110							
400 V/6 kV/3 – overvoltage category III							
690 V/6 kV/2 – overvoltage category II							
1000 V/6 kV/1 – overvoltage category I							
Drilling plan for version with 3.50/7.00 mm pitch with angled solder pin and locating cams							

PCB edge connector terminals

wiecon PCB

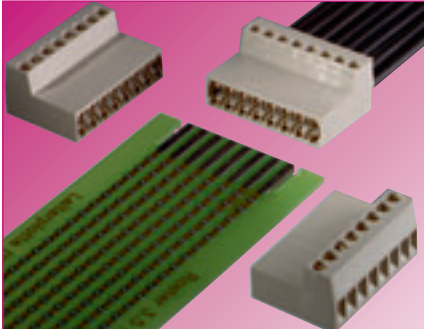

Edge connection describes the method used to connect a plug in terminal to a PCB without using a special connecting element such as a pluggable or pin header

System features

- rising cage clamp
- detachable connection
- clear, straight forward interconnection
- PCB thickness: 1.4 mm up to 1.8 mm
- floating contact springs ensure a secure resistant clamping function to the PCB

Coding

- coding does not effect the number of available poles
- PCB with coding slots for the location of the plug-in barriers in the contact part
- Coding can be effected by utilising slots in the contact part of the connector

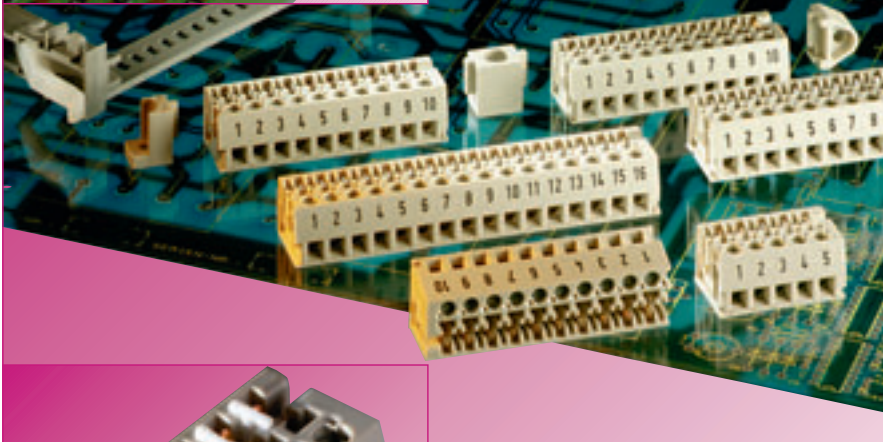
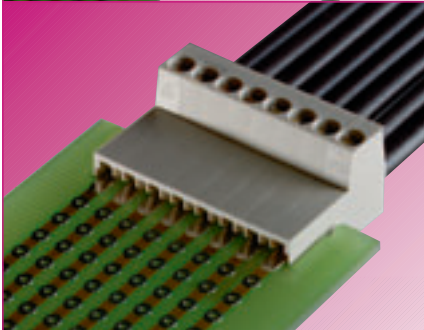

Marking

- by means of inkjet printer directly onto the using indelible ink
- clear pole marking which is easy to read
- special marking is possible on request

abbreviations for plastic material marking

PA 66/6 = Polyamide 66/6
PC = Polycarbonate
PBT = Polybutylenterephthalate

Type range

- 3.5 mm and 5 mm pitch
- 2 – 24 pole can be supplied
- connecting conductor sizes up to 1.5 mm²
- with open side walls for expansion without effecting the pitch or with closed side walls and therefore no possibility of miss connection
- with or without solder pin

Card holder

- for secure connection to the PCB and plug in connector
- special card brackets act as a guide when using large PCB's. With side locating cams at the top and bottom for attaching a perforated guide frame

Materials

Metal components:

- made from special alloys and/or special surface treatments
- minimum contact resistance
- high corrosion protection

Insulating housing:

- high quality polyamide, used because of its excellent electrical, mechanical and chemical properties (see **facts & DATA** section)
- material in accordance with US-Norm UL 94-V0
- Colour grey, similar to RAL 7032

Note:

The conductor size and connecting voltage current capacity relate to unprepared conductors without ferrules.



The rated current specified corresponds to the maximum load of PCB terminal and the size of the connected conductor.

The rated voltage is specified in accordance with DIN VDE 0110 Part 1 (IEC 60 664-1) – Insulation regulations for electrical equipment in low voltage installations and refers to the received condition of the PCB terminals.

When fitting PCB terminals to the PCB, the appropriate terminal should be selected with consideration given to the relevant electrical and physical properties suitable to the application. Also, attention should be paid to circuit board tracking, creepage and clearances as well as distances between individual conductor and solder pads.

In addition, the various forms of environmental pollutants and their degree of influence can effect the performance of a piece of equipment. A system approach is therefore required to ensure that the electrical and other parameters of the PCB terminal match those governed by the functionality of the printed circuit board design.

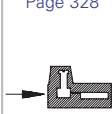
wiecon

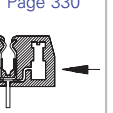
		Page 328	Page 328	Page 330	Page 330
					
Type		DST 85	DSTLF 85	LPST 1	LPSTL 1
Pitch	mm	3.50	3.50	5.00	5.00
Cross section	mm ²	1.5	1.5	2.5	2.5
Pole		2 – 24	2 – 24	2 – 20	2 – 20

It is necessary to ensure for all soldered PCB terminals without an insulation plate that the torques are supported when the clamping screws are tightened i.e. that the terminals are locked against rotation.

For prototypes, it is recommended that only 2 and 3 pole versions should be used with a contact plate/locating cams.



PCB edge connector, pitch 3.50 mm

wiecon PCB

Rated cross section
1.5 mm²

Rated current:
6 A

Wire range:
0.14 – 1.5 mm² single-/finely stranded

125 V/2.5 kV/3 – overvoltage category III
250 V/2.5 kV/2 – overvoltage category II
*690 V/2.5 kV/1 – overvoltage category I

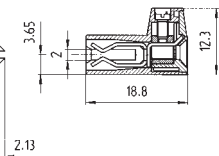
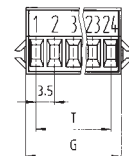
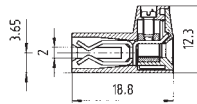
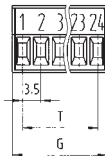

* max. 600 V for non earthed systems or expected overvoltage
≤ 3 kV for L ≥ 2.0 mm and ≤ 2.5 kV for 2.0 mm > L ≥ 1.5 mm

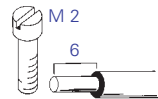

Type DST 85

Connection in line with conductor

No. 30 – 14 AWG 300 V 6 A
No. 30 – 14 AWG 300 V 6 A

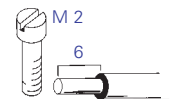

Type DST LF 85

Connection in line with conductor

No. 30 – 14 AWG 300 V 6 A
No. 30 – 14 AWG 300 V 6 A



Rated voltages VDE 0110

UL Data

CSA Data

Approvals

Box Qty	G	T	Pole	Part No.	Part No.	Part No.	Part No.
Pitch 3.50 mm				unmarked	marked	unmarked	marked
100	7.1	3.4	2	25.003.0253.0	25.002.0253.0	25.005.0253.0	25.004.0253.0
100	10.5	6.8	3	25.003.0353.0	25.002.0353.0	25.005.0353.0	25.004.0353.0
50	14.0	10.3	4	25.003.0453.0	25.002.0453.0	25.005.0453.0	25.004.0453.0
50	17.5	13.8	5	25.003.0553.0	25.002.0553.0	25.005.0553.0	25.004.0553.0
50	21.0	17.3	6	25.003.0653.0	25.002.0653.0	25.005.0653.0	25.004.0653.0
50	24.5	20.8	7	25.003.0753.0	25.002.0753.0	25.005.0753.0	25.004.0753.0
50	28.0	24.3	8	25.003.0853.0	25.002.0853.0	25.005.0853.0	25.004.0853.0
50	31.5	27.8	9	25.003.0953.0	25.002.0953.0	25.005.0953.0	25.004.0953.0
50	35.0	31.3	10	25.003.1053.0	25.002.1053.0	25.005.1053.0	25.004.1053.0
50	38.5	34.8	11	25.003.1153.0	25.002.1153.0	25.005.1153.0	25.004.1153.0
50	42.0	38.3	12	25.003.1253.0	25.002.1253.0	25.005.1253.0	25.004.1253.0
only available up to 12 pole							

Thickness of PCB: 1.4 mm – 1.8 mm

Materials

PCB terminals

Insulating housing: PA 66/6 grey,
UL 94-V0

Clamping parts: nickel plated brass

Clamping screw: galvanised steel

Contact spring: tin plated bronze

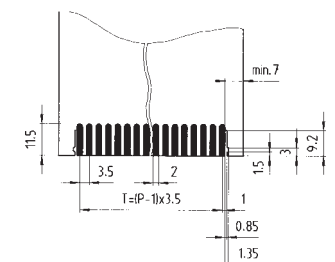
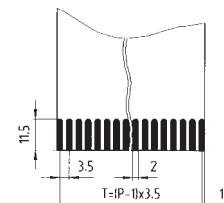

wiecon

PCB edge connector, pitch 5.00 mm

wiecon PCB

Rated cross section:
2.5 mm²

Rated current:
5 A

Wire range:
0.14 – 4.0 mm² single core/
0.14 – 2.5 mm² finely stranded

200 V/4 kV/3 – overvoltage category III
320 V/4 kV/2 – overvoltage category II
1000 V/4 kV/1 – overvoltage category I

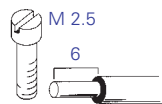
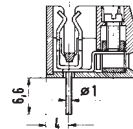
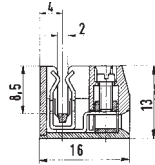

without solder connection for PCB

Type LPST 1

connection at 90° to conductor

No. 22 – 14 AWG 300 V 5 A
No. 22 – 14 AWG 300 V 5 A

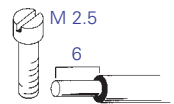
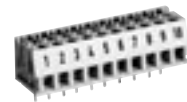

with solder connection for PCB

Type LPSTL 1

connection at 90° to conductor

No. 22 – 14 AWG 300 V 5 A
No. 22 – 14 AWG 300 V 5 A



Rated voltages VDE 0110
UL Data
CSA Data
Approvals

Box Qty	U	G	T	Pole	Part No.	Part No.	Part No.
pitch 5.00 mm							
					marked	unmarked	marked
100	25	14	5	2	25.000.0256.0	25.010.0256.0	25.001.0256.0
100	30	19	10	3	25.000.0356.0	25.010.0356.0	25.001.0356.0
50	35	24	15	4	25.000.0456.0	25.010.0456.0	25.001.0456.0
50	40	29	20	5	25.000.0556.0	25.010.0556.0	25.001.0556.0
50	45	34	25	6	25.000.0656.0	25.010.0656.0	25.001.0656.0
50	50	39	30	7	25.000.0756.0	25.010.0756.0	25.001.0756.0
50	55	44	35	8	25.000.0856.0	25.010.0856.0	25.001.0856.0
50	60	49	40	9	25.000.0956.0	25.010.0956.0	25.001.0956.0
50	65	54	45	10	25.000.1056.0	25.010.1056.0	25.001.1056.0
50	70	59	50	11	25.000.1156.0	25.010.1156.0	25.001.1156.0
50	75	64	55	12	25.000.1256.0	25.010.1256.0	25.001.1256.0
50	80	69	60	13	25.000.1356.0	25.010.1356.0	25.001.1356.0
50	85	74	65	14	25.000.1456.0	25.010.1456.0	25.001.1456.0
50	90	79	70	15	25.000.1556.0	25.010.1556.0	25.001.1556.0
50	95	84	75	16	25.000.1656.0	25.010.1656.0	25.001.1656.0

17 to 20 pole on request

Thickness of PCB: 1.4 mm – 1.8 mm

Materials

PCB terminals

Insulating housing: reinforced PA grey,
UL 94-V2

Clamping part: nickel plated brass

Clamping screw: galvanised steel

Contact spring: bronze

– silver plated for LPST 1

– tin plated for LPSTL 1

Accessories

wiecon

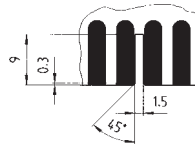
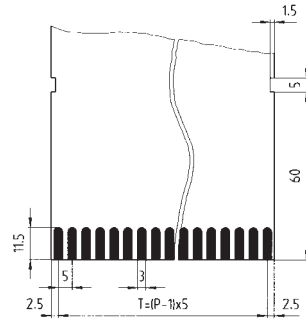

The PCB edge connectors are fixed by means of mounting brackets. PCB guides are to be used with the card bracket in the case of large PCBs. These brackets have locating cams top and bottom and on both sides to which perforated strips can be fixed if necessary. This provides a stable guide frame.

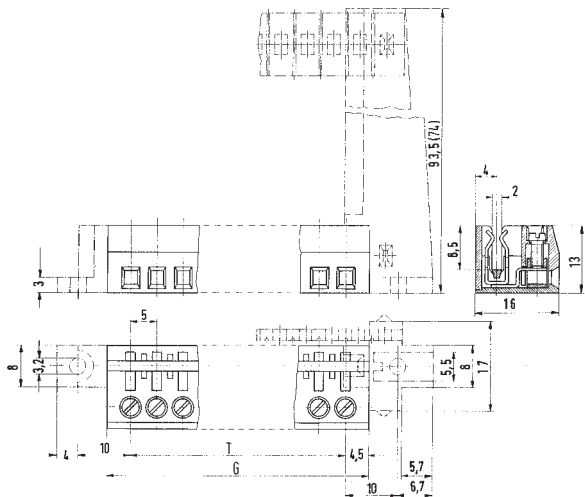

Type	Part No.	Box Qty
------	----------	---------



Mounting bracket H 93.5 mm with PCB guide locating lever	05.593.8853.0 05.594.3653.0	100 200
---	--------------------------------	------------

Mounting bracket H 74 mm with PCB guide with locating cams	05.599.2853.0	100
without locating cams	05.599.2953.0	100



Perforated strip	07.413.3653.0	100
------------------	---------------	-----



Coding chip	05.593.7756.0	500
-------------	---------------	-----



Mounting bracket	05.522.7356.0	200
------------------	---------------	-----



Mounting bracket	05.522.7856.0	200
------------------	---------------	-----



Centre clamp	05.522.7756.0	100
--------------	---------------	-----

* outer wall can be right, left or absent as components are created by cutting to the corresponding number of poles → external coding is not possible

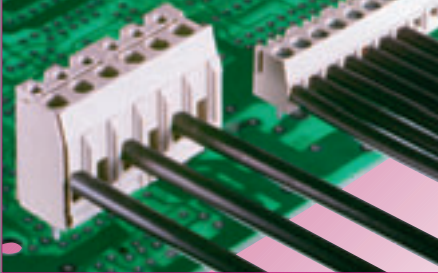
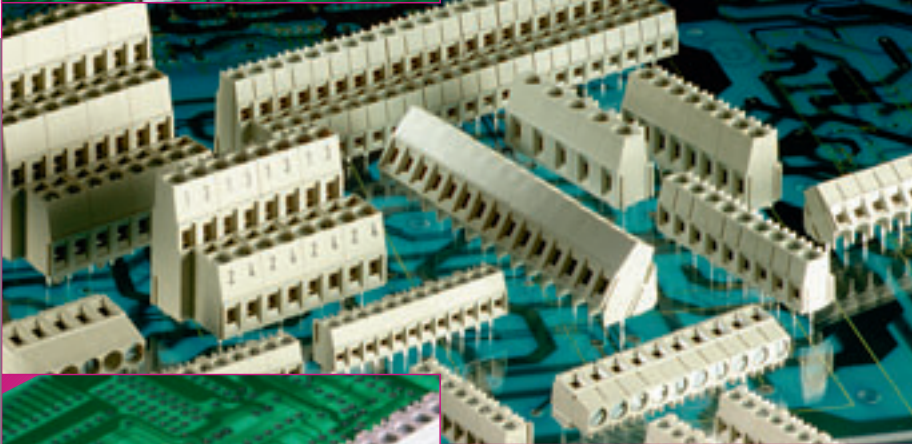
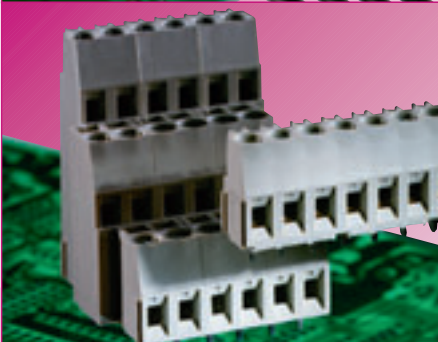
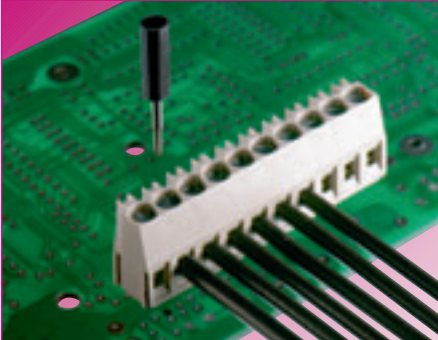

Systems feature

- PCB terminals with rising cage clamp connection
- PCB terminal with spring loaded connection
- PCB terminal with top connection
- terminal can be soldered directly onto PCB
- low mechanical loading of the solder area
- straight forward interconnection
- conductors can be individually matched to the relevant applications
- various numbers of pole combinations
- connection of single core and finely stranded conductors between 0.14 mm² and 16 mm²
- metric and imperial pitch sizes. The pitch measured in inches can be identified by a pip on the conductor guide funnel
- conductor clamping by means of rising cage clamp with/without wire protection

Marking

- by means of ink jet printing directly onto the terminal using indelible ink
- individual terminals can be marked using snap-on marking tags
- terminals with or without marking tag carrier
- special marking is possible on request

Abbreviations for plastic material markings

PA 66/6 = Polyamide 66/6
 PC = Polycarbonate
 PBT = Polybutylenterephthalate

Type range

- 2 – 24 poles
- connection of conductors horizontal and vertical in relation to the PCB
- conductors can be connected at a 45° or 35°
- with metric:
3.5/5/7.5/10) mm
or imperial:
3.81/5.08/7.62/10.16/20.32 mm
- slot together individual terminals
- multipole blocks
- with or without insulating plate
- with or without testing plug connection
- with or without fixing cams

Materials

metal components

- made from special alloys and/or special surface treatments
- low contact resistance
- high corrosion protection
- secure, dynamic clamping functions

Insulating housing

- high quality Polyamide 66/6 used because of its excellent electrical, mechanical and chemical properties (see individual terminals for material marking)

Benefits

- material in accordance with UL 94-V0
- glass filled for additional reinforcement

DQS certification for all product areas

- Quality standard in accordance with DIN ISO 9001
- In development, production and installation
- Continued control of the quality standard by means of regular internal and external quality audits
- Compatible with certificates of other countries:
 - BSI, Great Britain
 - SQS, Switzerland
 - Aib-Vincotte, Belgium
 - ÖQS, Austria

wiecon

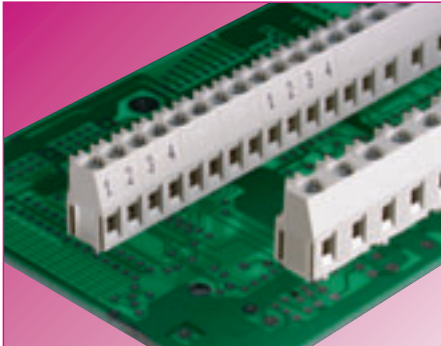

Insulating plate

- metal components covered with a plastic plate
- The safety ratings for creepage distances and clearances can be observed even with the PCB tracks directly under the PCB terminal
- with 2 and 3 pole terminals, fixing cams on the insulating plate reduce the effect of mechanical force on terminal and solder area

Top connection

- screw connection parallel to the connecting lead
- very good accessibility for the operator in restricted installation conditions
- snap-on marker tag
- double solder pins for stability

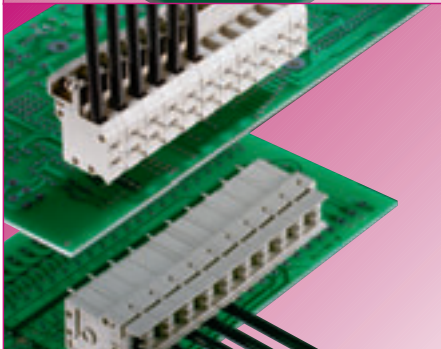

Individual terminals

- terminals snap together individually
- secure connection
- the pitch can be expanded by means of an intermediate plate
- pitches available in the following sizes: 5.00/5.08/6.35/7.50/7.62/10.00/10.16/20.32 mm
- with cover plate
- double solder pins for stability

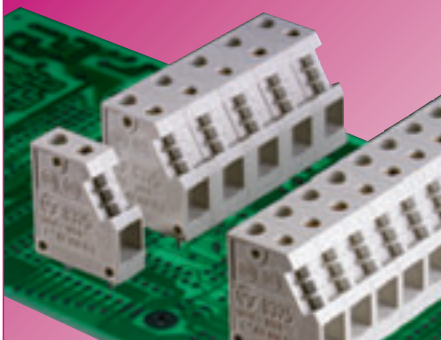

Special terminals

- snap together individually
- pitch 5.08 mm
- secure fixing to the PCB with double solder pins
- modular terminal
- disconnect terminal
- fuse terminal with removable fuse link and integrated return conductor
- test socket for 2 mm or 3 mm test plug

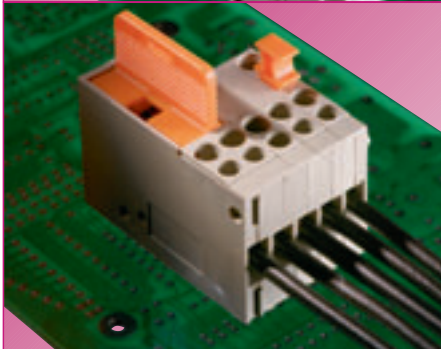

Note:

The conductor size and connecting voltage/current capacity relate to unprepared conductors without ferrules.

The rated current specified corresponds to the maximum load of the PCB terminal and the size of the connected conductor.

The rated voltage is specified in accordance with DIN VDE 0110 Part 1 (IEC 60 664-1) – Insulation regulations for electrical equipment in low voltage installations and refers to the received condition of the PCB terminals.

When fitting PCB terminals to the PCB, the appropriate terminal should be selected with consideration given to the relevant electrical and physical properties suited to the application. Also, attention should be paid to circuit board tracking creepage and clearances as well as distances between individual conductors and solder pads.

In addition, the various forms of environmental pollutants and their degree of influence can effect the performance of a piece of equipment. A system approach is therefore required to ensure that the electrical and other parameters of the PCB terminal match those governed by the functionality of the printed circuit board design.

PCB terminals

wiecon PCB

PCB terminals

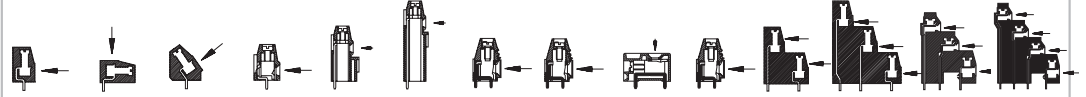

Cross section (finely stranded)	pitch	Rising cage clamp												
1 mm ²	3.50	8593 page 336												
	3.81	8893 page 336												
1.5 mm ²	5.00/ 10.00	8192 page 338	8192 ZW page 339	8134 page 360								8192 E page 364	8195 D page 372	8195 V page 375
	5.08	8292 page 338	8292 ZW page 339	8234 page 360	8292 H page 341	8292 EH page 340	8292 DH page 340					8292 E page 364		
	7.50													
	7.62													
2.5 mm ²	5.00/ 10.00	8190 page 358 8191 page 344	8191 ZW page 345	8135 page 362								8190 E page 368 8191 E page 357	8191 D page 357	
	5.00	8191 R page 342	8191 page 344										8195 D page 372	8195 V page 373
	5.08	8291 R page 342 8291 page 357	8291 ZW page 357	8235 page 357								8291 E page 357	8291 D page 357	
	7.50	8390 page 359 8491 page 346	8391 ZW page 347											
	7.62	8491 page 346	8491 ZW page 347											
4 mm ²	6.35													
	7.50													
	7.62													
	10.00													
10 mm ²	10.16									7572 L2 page 376	7572 L4 page 376	7573 L2/W page 375		
	20.32											7572 L2 page 376		

PCB terminal, rising cage clamp system pitch 3.50/3.81 mm

wiecon PCB

Rated cross section:
1.0 mm²

Rated current:
10 A

Wire range:
0.14 – 1.5 mm² single core/
0.14 – 1.0 mm² finely stranded

160 V/2.5 kV/3 – overvoltage category III
*250 V/2.5 kV/2 – overvoltage category II
**690 V/2.5 kV/1 – overvoltage category I

* up to 400 V in overvoltage category I
or expected overvoltage ≤ 3 kV for L ≥ 2.0 mm and ≤ 2.5 kV for
2.0 mm > L ≥ 1.5 mm

** max. 600 V for non-earthed systems or expected overvoltage ≤
3 kV for L ≥ 2.0 mm and ≤ 2.5 kV for 2.0 mm > L ≥ 1.5 mm

without insulating plate

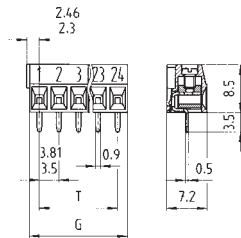

with insulating plate

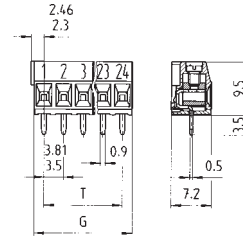

Solder pin 0.5 x 0.9 mm
Drill hole Ø 1.1 mm

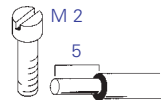

Type 8593/8893

Conductor horizontal to PCB

No. 30 – 16 AWG

300 V 10 A

No. 30 – 16 AWG

300 V 10 A



Materials

Insulating housing: PA 66/6 grey,
UL 94-V2

Clamping part: nickel plated brass
Contact and solder pin:

tin plated bronze

Clamping screw: galvanised steel

Rated voltages VDE 0110

UL Data

CSA Data

Approvals

Box Qty	L	T	Pole	Part No.	Part No.	Part No.	Part No.
				unmarked without insulating plate	marked without insulating plate	unmarked with insulating plate with locating cams	marked with insulating plate with locating cams
pitch 3.50 mm							
100	7.0	3.5	2	25.195.0253.0	25.194.0253.0	25.195.9253.0	25.194.9253.0
100	10.5	7.0	3	25.195.0353.0	25.194.0353.0	25.195.9353.0	25.194.9353.0
50	14.0	10.5	4	25.195.0453.0	25.194.0453.0		
50	17.5	14.0	5	25.195.0553.0	25.194.0553.0		
50	21.0	17.5	6	25.195.0653.0	25.194.0653.0		
50	24.5	21.0	7	25.195.0753.0	25.194.0753.0		
50	28.0	24.5	8	25.195.0853.0	25.194.0853.0		
50	31.5	28.0	9	25.195.0953.0	25.194.0953.0		
50	35.0	31.5	10	25.195.1053.0	25.194.1053.0		
50	38.5	35.0	11	25.195.1153.0	25.194.1153.0		
50	42.0	38.5	12	25.195.1253.0	25.194.1253.0		
50	45.5	42.0	13	25.195.1353.0	25.194.1353.0		
50	49.0	45.5	14	25.195.1453.0	25.194.1453.0		
50	52.5	49.0	15	25.195.1553.0	25.194.1553.0		
50	56.0	52.5	16	25.195.1653.0	25.194.1653.0		
17 to 24 pole on request							
				unmarked without insulating plate	marked without insulating plate	unmarked with insulating plate with locating cams	marked with insulating plate with locating cams
pitch 3.81 mm							
100	7.62	3.81	2	25.197.0253.0	25.196.0253.0	25.197.9253.0	25.196.9253.0
100	11.43	7.62	3	25.197.0353.0	25.196.0353.0	25.197.9353.0	25.196.9353.0
50	15.24	11.43	4	25.197.0453.0	25.196.0453.0		
50	19.50	15.24	5	25.197.0553.0	25.196.0553.0		
50	22.86	19.05	6	25.197.0653.0	25.196.0653.0		
50	26.67	22.86	7	25.197.0753.0	25.196.0753.0		
50	30.48	26.67	8	25.197.0853.0	25.196.0853.0		
50	34.29	30.48	9	25.197.0953.0	25.196.0953.0		
50	38.10	34.29	10	25.197.1053.0	25.196.1053.0		
50	41.91	38.10	11	25.197.1153.0	25.196.1153.0		
50	45.72	41.91	12	25.197.1253.0	25.196.1253.0		
50	49.53	45.72	13	25.197.1353.0	25.196.1353.0		
50	53.34	49.53	14	25.197.1453.0	25.196.1453.0		
50	57.15	53.34	15	25.197.1553.0	25.196.1553.0		
50	60.96	57.15	16	25.197.1653.0	25.196.1653.0		
17 to 24 pole on request							

wiecon

with insulating plate and locating cams

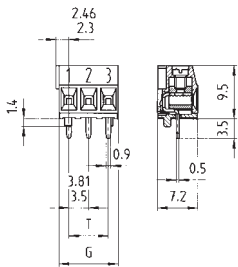

Drilling plan for version with locating cams

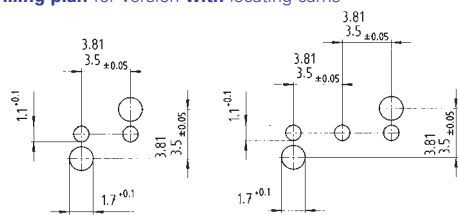

Part No.	Part No.
unmarked with insulating plate without locating cams on request	marked with insulating plate without locating cams on request
unmarked with insulating plate without locating cams on request	marked with insulating plate without locating cams on request

PCB terminal, rising cage clamp system, pitch 5.00/5.08 mm

wiecon PCB

Rated cross section:
1.5 mm²

Rated current:
10 A

Wire range:
0.14 – 2.5 mm² single core/
0.14 – 1.5 mm² finely stranded

250 V/4 kV/3 – overvoltage category III
*690 V/4 kV/2 – overvoltage category II
1000 V/4 kV/1 – overvoltage category I

without insulating plate

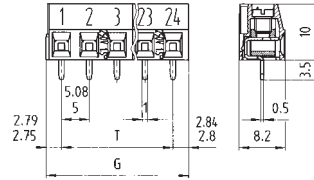

with insulating plate

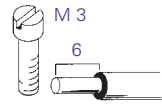
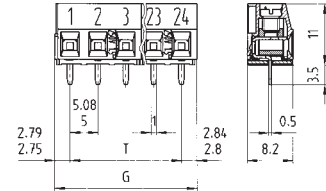

Solder pin 0.5 x 1 mm
Drill hole Ø 12 mm

* max. 600 V for non-earthed systems or expected overvoltage
≤ 4 kV

Type 8192/8292

Conductor horizontal to PCB

No. 30 – 14 AWG

300 V 15/16 A

No. 30 – 14 AWG

300 V 15 A



Materials

Insulating housing: PA 66/6 grey, UL 94-V0
Clamping part: nickel plated brass
Contact and solder pin: tin plated bronze
Clamping screw: galvanised steel

Rated voltages VDE 0110

UL Data

CSA Data

Approvals

Box Qty	G	T	Pole	Part No.	Part No.	Part No.	Part No.
pitch 5.00 mm				unmarked without insulating plate	marked without insulating plate	unmarked with insulating plate with locating cams	marked with insulating plate with locating cams
100	10.55	5	2	25.191.0253.0	25.190.0253.0	25.191.9253.0	25.190.9253.0
100	15.55	10	3	25.191.0353.0	25.190.0353.0	25.191.9353.0	25.190.9353.0
50	20.55	15	4	25.191.0453.0	25.190.0453.0		
50	25.55	20	5	25.191.0553.0	25.190.0553.0		
50	30.55	25	6	25.191.0653.0	25.190.0653.0		
50	35.55	30	7	25.191.0753.0	25.190.0753.0		
50	40.55	35	8	25.191.0853.0	25.190.0853.0		
50	45.55	40	9	25.191.0953.0	25.190.0953.0		
50	50.55	45	10	25.191.1053.0	25.190.1053.0		
50	55.55	50	11	25.191.1153.0	25.190.1153.0		
50	60.55	55	12	25.191.1253.0	25.190.1253.0		
50	65.55	60	13	25.191.1353.0	25.190.1353.0		
50	70.55	65	14	25.191.1453.0	25.190.1453.0		
50	75.55	70	15	25.191.1553.0	25.190.1553.0		
50	80.55	75	16	25.191.1653.0	25.190.1653.0		
17 to 24 pole on request							
pitch 5.08 mm				unmarked without insulating plate	marked without insulating plate	unmarked with insulating plate with locating cams	marked with insulating plate with locating cams
100	10.71	5.08	2	25.193.0253.0	25.192.0253.0	25.193.9253.0	25.192.9253.0
100	15.79	10.16	3	25.193.0353.0	25.192.0353.0	25.193.9353.0	25.192.9353.0
50	20.87	15.24	4	25.193.0453.0	25.192.0453.0		
50	25.95	20.32	5	25.193.0553.0	25.192.0553.0		
50	31.03	25.40	6	25.193.0653.0	25.192.0653.0		
50	36.11	30.48	7	25.193.0753.0	25.192.0753.0		
50	41.19	35.56	8	25.193.0853.0	25.192.0853.0		
50	46.27	40.64	9	25.193.0953.0	25.192.0953.0		
50	51.35	45.72	10	25.193.1053.0	25.192.1053.0		
50	56.43	50.80	11	25.193.1153.0	25.192.1153.0		
50	61.51	55.88	12	25.193.1253.0	25.192.1253.0		
50	66.59	60.96	13	25.193.1353.0	25.192.1353.0		
50	71.67	66.04	14	25.193.1453.0	25.192.1453.0		
50	76.75	71.12	15	25.193.1553.0	25.192.1553.0		
50	81.83	76.20	16	25.193.1653.0	25.192.1653.0		
17 to 24 pole on request							

wiecon

with insulating plate with locating cams

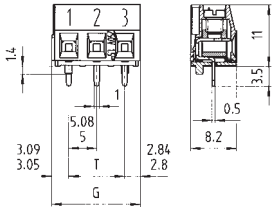

with insulating plate, horizontal

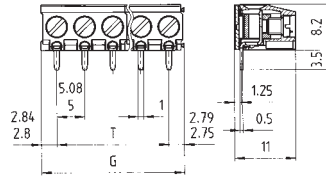

Drilling plan for version with locating cams

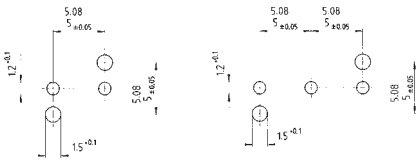

Solder pin 0.5 x 1 mm
Drill hole Ø 12 mm

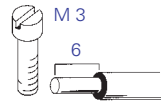

Type 8192 ZW/8292 ZW

Conductor vertical to PCB

VDE 0110

UL-Daten

CSA-Daten

Zulassungen

field/factory wiring

No. 30 – 14 AWG

300 V 15/16 A

No. 30 – 14 AWG

300 V 15 A



Part No.	Part No.	Part No.	Part No.
unmarked with insulating plate without locating cams	marked with insulating plate without locating cams	unmarked with insulating plate horizontal	marked with insulating plate horizontal
on request		25.191.6253.0 25.191.6353.0 25.191.6453.0	on request
		25.191.6553.0 25.191.6653.0 25.191.6753.0	
		25.191.6853.0 25.191.6953.0 25.191.7053.0	
		25.191.7153.0 25.191.7253.0 25.191.7353.0	
		25.191.7453.0 25.191.7553.0 25.191.7653.0	
unmarked with insulating plate without locating cams	marked with insulating plate without locating cams	unmarked with insulating plate horizontal	marked with insulating plate horizontal
on request		25.193.6253.0 25.193.6353.0 25.193.6453.0	on request
		25.193.6553.0 25.193.6653.0 25.193.6753.0	
		25.193.6853.0 25.193.6953.0 25.193.7053.0	
		25.193.7153.0 25.193.7253.0 25.193.7353.0	
		25.193.7453.0 25.193.7553.0 25.193.7653.0	

wiecon

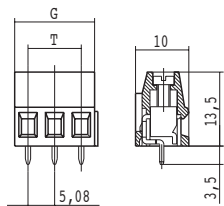

Solder pin 0.8 x 1 mm
Drill hole Ø 1.3 mm

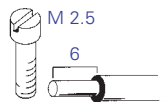

Type 8292 H

No. 24 – 14 AWG 300 V 10 A
No. 24 – 14 AWG 300 V 10 A



Part No.	Part No.
unmarked	
27.000.0253.0	
27.000.0353.0	

PCB terminal, rising cage clamp system, pitch 5.00/5.08 mm

wiecon PCB

Rated cross section:
2.5 mm²

Rated current:
16 A

Wire range:
0.14 – 4.0 mm² single core/
0.14 – 2.5 mm² finely stranded

250 V/4 kV/3 – overvoltage category III
*690 V/4 kV/2 – overvoltage category II
1000 V/4 kV/1 – overvoltage category I

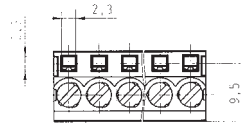
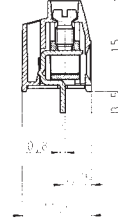
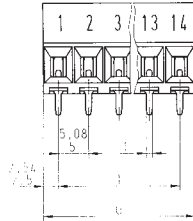

Materials
Insulating housing: PA 66/6 grey,
UL 94-V0
Clamping part: nickel plated brass
Contact and solder pin:
tin plated E-Cu
Clamping screw: galvanised steel

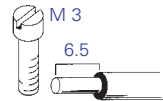

Solder pin 1 x 0.8 mm
Drill hole Ø 1.3 mm

Available with slotted screw
on request

* max. 600 V for non-earthed systems or expected overvoltage ≤ 4 kV

Type 81 – 8291 R

Conductor horizontal to PCB

[with closed test probe)

No. 22 – 12 AWG

300 V 20/30 A

No. 22 – 12 AWG

300 V 25 A



Rated voltages VDE 0110

UL Data

CSA Data

Approvals

Box Qty	G	T	Pole	Part No.	Part No.
pitch 5.00 mm				Type 8191 R	
				unmarked with insulating plate	marked with insulating plate
500	10.85	5	2	25.155.0253.0	25.155.2253.0
500	15.85	10	3	25.155.0353.0	25.155.2353.0
250	20.85	15	4	25.155.0453.0	25.155.2453.0
250	25.85	20	5	25.155.0553.0	25.155.2553.0
200	30.85	25	6	25.155.0653.0	25.155.2653.0
200	35.85	30	7	25.155.0753.0	25.155.2753.0
100	40.85	35	8	25.155.0853.0	25.155.2853.0
100	45.85	40	9	25.155.0953.0	25.155.2953.0
100	50.85	45	10	25.155.1053.0	25.155.3053.0
50	55.85	50	11	25.155.1153.0	25.155.3153.0
50	60.85	55	12	25.155.1253.0	25.155.3253.0
50	66.85	60	13	25.155.1353.0	25.155.3353.0
50	70.85	65	14	25.155.1453.0	25.155.3453.0
pitch 5.08 mm				Type 8291 R	
				unmarked with insulating plate	marked with insulating plate
500	11.01	5.08	2	25.156.0253.0	25.156.2253.0
500	16.09	10.16	3	25.156.0353.0	25.156.2353.0
250	21.17	15.24	4	25.156.0453.0	25.156.2453.0
250	26.25	20.32	5	25.156.0553.0	25.156.2553.0
200	31.33	25.40	6	25.156.0653.0	25.156.2653.0
200	36.41	30.48	7	25.156.0753.0	25.156.2753.0
100	41.49	35.56	8	25.156.0853.0	25.156.2853.0
100	46.57	40.64	9	25.156.0953.0	25.156.2953.0
100	51.56	45.72	10	25.156.1053.0	25.156.3053.0
50	56.73	50.80	11	25.156.1153.0	25.156.3153.0
50	61.81	55.88	12	25.156.1253.0	25.156.3253.0
50	66.89	60.96	13	25.156.1353.0	25.156.3353.0
50	71.97	66.04	14	25.156.1453.0	25.156.3453.0

PCB terminal, rising cage clamp system, pitch 10.00/10.16 mm

Rated cross section:
2.5 mm²

Rated current:
16 A

Wire range:
0.14 – 4.0 mm² single core/
0.14 – 2.5 mm² finely stranded

690 V/8 kV/3 – overvoltage category III
1000 V/8 kV/2 – overvoltage category II
1000 V/8 kV/1 – overvoltage category I

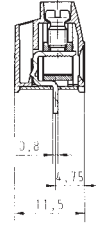
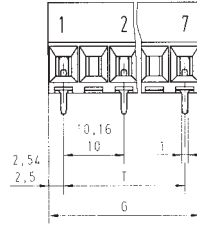

Materials
Insulating housing: PA 66/6 grey,
UL 94-V0
Clamping part: nickel plated brass
Contact and solder pin:
tin plated E-Cu
Clamping screw: galvanised steel

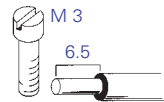
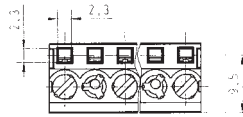

Solder pin 1 x 0.8 mm
Drill hole Ø 1.3 mm

Available with slotted screw
on request

Type 81 – 8291 R

Conductor horizontal to PCB

(with closed test probe, each fitted with 2 poles)

No. 22 – 12 AWG 600 V 20/30 A

No. 22 – 12 AWG 600 V 25 A



Rated voltages VDE 0110
UL Data
CSA Data
Approvals

Box Qty	G	T	Pole	Part No.	Part No.
pitch 10.00 mm				unmarked with insulating plate	marked with insulating plate
Type 8191 R					
500	15	10	2	25.157.0253.0	25.157.1253.0
250	25	20	3	25.157.0353.0	25.157.1353.0
200	35	30	4	25.157.0453.0	25.157.1453.0
100	45	40	5	25.157.0553.0	25.157.1553.0
50	55	50	6	25.157.0653.0	25.157.1653.0
50	65	60	7	25.157.0753.0	25.157.1753.0
pitch 10.16 mm				unmarked with insulating plate	marked with insulating plate
Type 8291 R					
500	15.24	10.16	2	25.157.4253.0	25.157.5253.0
250	25.40	20.32	3	25.157.4353.0	25.157.5353.0
200	35.56	30.48	4	25.157.4453.0	25.157.5453.0
100	45.72	40.64	5	25.157.4553.0	25.157.5553.0
50	55.88	50.80	6	25.157.4653.0	25.157.5653.0
50	66.04	60.96	7	25.157.4753.0	25.157.5753.0

PCB terminal, rising cage clamp system, pitch 5.00/5.08/10.00 mm

wiecon PCB

Rated cross section:
2.5 mm²

Rated current:
16 A

Wire range:
0.14 – 4.0 mm² single core/
0.14 – 2.5 mm² finely stranded

Rated voltages:
pitch 5.00/5.08 mm VDE 0110
250 V/4 kV/3 – overvoltage category III
*690 V/4 kV/2 – overvoltage category II
1000 V/4 kV/1 – overvoltage category I

Rated voltages:
pitch 10.00 mm VDE 0110
690 V/8 kV/3 – overvoltage category III
1000 V/8 kV/2 – overvoltage category II
1000 V/8 kV/1 – overvoltage category I

* max. 600 V for non-earthed systems or expected overvoltage
≤ 4 kV

Rated voltages VDE 0110

UL Data

CSA Data

Approvals

field/factory wiring

pitch 5.00/5.08 mm, without insulating plate

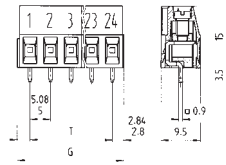

with insulating plate, without locating cams

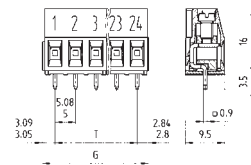

pitch 10.00 mm, without insulating plate

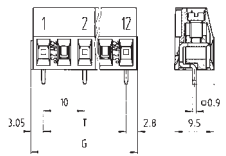

with insulating plate, without locating cams

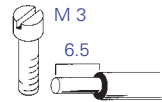
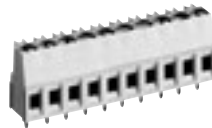
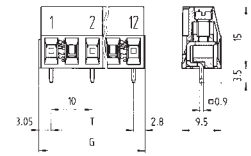

Solder pin 0.9 x 0.9 mm
Drill hole Ø 1.3 mm

Type 8191/8291

Conductor horizontal to PCB

(with open test probe)

No. 22 – 12 AWG

300 V 20/30 A

No. 22 – 12 AWG

300 V 25 A



Box Qty	G	T	Pole	Part No.	Part No.	Part No.	Part No.
				unmarked without insulating plate	marked without insulating plate	unmarked with insulating plate with locating cams	marked with insulating plate with locating cams
pitch 5.00 mm							
100	10.85	5	2	25.161.0253.0	25.160.0253.0	25.171.0253.0	25.170.0253.0
100	15.85	10	3	25.161.0353.0	25.160.0353.0	25.171.0353.0	25.170.0353.0
50	20.85	15	4	25.161.0453.0	25.160.0453.0		
50	25.85	20	5	25.161.0553.0	25.160.0553.0		
50	30.85	25	6	25.161.0653.0	25.160.0653.0		
50	35.85	30	7	25.161.0753.0	25.160.0753.0		
50	40.85	35	8	25.161.0853.0	25.160.0853.0		
50	45.85	40	9	25.161.0953.0	25.160.0953.0		
50	50.85	45	10	25.161.1053.0	25.160.1053.0		
50	55.85	50	11	25.161.1153.0	25.160.1153.0		
50	60.85	55	12	25.161.1253.0	25.160.1253.0		
50	65.85	60	13	25.161.1353.0	25.160.1353.0		
50	70.85	65	14	25.161.1453.0	25.160.1453.0		
50	75.85	70	15	25.161.1553.0	25.160.1553.0		
50	80.85	75	16	25.161.1653.0	25.160.1653.0		
17 to 24 pole on request							
pitch 5.08 mm							
100	11.01	5.08	2	25.163.0253.0	25.162.0253.0	25.173.0253.0	25.172.0253.0
100	16.09	10.16	3	25.163.0353.0	25.162.0353.0	25.173.0353.0	25.172.0353.0
50	21.17	15.24	4	25.163.0453.0	25.162.0453.0		
50	26.25	20.32	5	25.163.0553.0	25.162.0553.0		
50	31.33	25.40	6	25.163.0653.0	25.162.0653.0		
50	36.41	30.48	7	25.163.0753.0	25.162.0753.0		
50	41.49	35.56	8	25.163.0853.0	25.162.0853.0		
50	46.57	40.64	9	25.163.0953.0	25.162.0953.0		
50	51.65	45.72	10	25.163.1053.0	25.162.1053.0		
50	56.73	50.80	11	25.163.1153.0	25.162.1153.0		
50	61.81	55.88	12	25.163.1253.0	25.162.1253.0		
50	66.89	60.96	13	25.163.1353.0	25.162.1353.0		
50	71.97	66.04	14	25.163.1453.0	25.162.1453.0		
50	77.05	71.12	15	25.163.1553.0	25.162.1553.0		
50	82.13	76.20	16	25.163.1653.0	25.162.1653.0		
17 to 24 pole on request							
pitch 10.00 mm							
4 to 12 pole on request	100	15.85	10	25.169.0253.0	25.168.0253.0	25.169.6253.0	25.168.6253.0
	50	25.85	20	25.169.0353.0	25.168.0353.0	25.169.6353.0	25.168.6353.0

wiecon

with insulating plate with locating cams

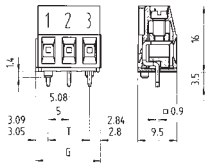

with insulating plate with locating cams

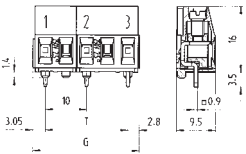

with insulating plate horizontal 5.00/5.08 mm

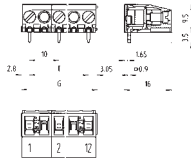

with insulating plate horizontal 10.00 mm

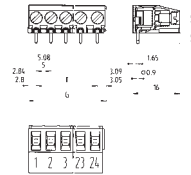

Solder pin 0.9 x 0.9 mm
Drill hole Ø 1.3 mm

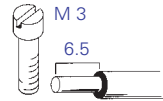

Type 8191 ZW/8291 ZW

Conductor vertical to PCB

No. 22 – 12 AWG

300 V 20/30 A

No. 22 – 12 AWG

300 V 25 A



Materials
Insulating housing: PA 66/6 grey,
UL 94-V0
Clamping part: nickel plated brass
Contact and solder pin:
tin plated E-Cu
Clamping screw: galvanised steel

Drilling plan for version with locating cams,
pitch 5.00/5.08 mm

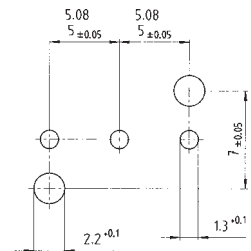
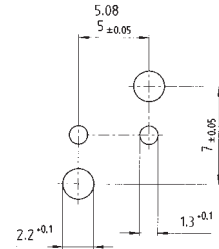

Drilling plan for version with locating cams,
pitch 10.00 mm

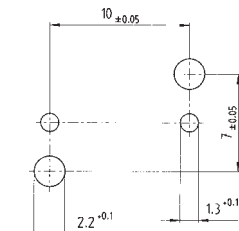
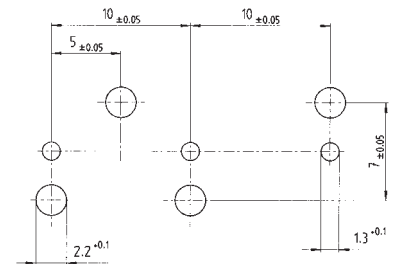

Part No.	Part No.	Part No.	Part No.
unmarked with insulating plate without locating cams	marked with insulating plate without locating cams	unmarked with insulating plate horizontal	marked with insulating plate horizontal
on request	on request	25.161.6253.0 25.161.6353.0 25.161.6453.0	25.160.6253.0 25.160.6353.0 25.160.6453.0
		25.161.6553.0 25.161.6653.0 25.161.6753.0	25.160.6553.0 25.160.6653.0 25.160.6753.0
		25.161.6853.0 25.161.6953.0 25.161.7053.0	25.160.6853.0 25.160.6953.0 25.160.7053.0
		25.161.7153.0 25.161.7253.0 25.161.7353.0	25.160.7153.0 25.160.7253.0 25.160.7353.0
		25.161.7453.0 25.161.7553.0 25.161.7653.0	25.160.7453.0 25.160.7553.0 25.160.7653.0
on request	on request	25.163.6253.0 25.163.6353.0 25.163.6453.0	25.162.6253.0 25.162.6353.0 25.162.6453.0
		25.163.6553.0 25.163.6653.0 25.163.6753.0	25.162.6553.0 25.162.6653.0 25.162.6753.0
		25.163.6853.0 25.163.6953.0 25.163.7053.0	25.162.6853.0 25.162.6953.0 25.162.7053.0
		25.163.7153.0 25.163.7253.0 25.163.7353.0	25.162.7153.0 25.162.7253.0 25.162.7353.0
		25.163.7453.0 25.163.7553.0 25.163.7653.0	25.162.7453.0 25.162.7553.0 25.162.7653.0
25.169.2253.0 25.169.2353.0	25.168.2253.0 25.168.2353.0	25.169.4253.0 25.169.4353.0	25.168.4253.0 25.168.4353.0

PCB terminal, rising cage clamp system, pitch 7.50/7.62 mm

wiecon PCB

Rated cross section:
2.5 mm²

Rated current:
16 A

Wire range:
0.14 – 4.0 mm² single core/
0.14 – 2.5 mm² finely stranded

400 V/6 kV/3 – overvoltage category III
1000 V/6 kV/2 – overvoltage category II
1000 V/6 kV/1 – overvoltage category I

without insulating plate

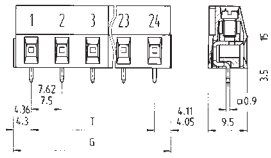

with insulating plate, **without** locating cams

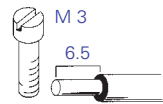
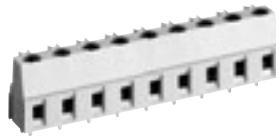
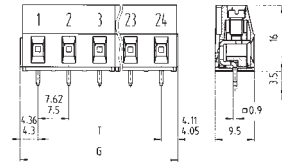

Solder pin 0.9 x 0.9 mm
Drill hole Ø 1.3 mm

Type 8391/8491

Conductor horizontal to PCB

No. 22 – 12 AWG
No. 22 – 12 AWG

300 V 20/30 A
300 V 25 A



Materials

Insulating housing: PA 66/6 grey, UL 94-V0
Clamping part: nickel plated brass
Contact and solder pin: tin plated E-Cu
Clamping screw: galvanised steel

Rated voltages VDE 0110
UL Data
CSA Data
Approvals

Box Qty	G	T	Pole	Part No.	Part No.	Part No.	Part No.
pitch 7.50 mm				unmarked without insulating plate	unmarked with insulating plate without locating cams	unmarked with insulating plate with locating cams	marked without insulating plate
100	15.85	7.5	2	25.165.0253.0	25.165.3253.0	25.175.0253.0	25.164.0253.0
100	23.35	15.0	3	25.165.0353.0	25.165.3353.0	25.175.0353.0	25.164.0353.0
4 to 24 pole on request							
pitch 7.62 mm				unmarked without insulating plate	unmarked with insulating plate without locating cams	unmarked with insulating plate with locating cams	marked without insulating plate
100	16.09	7.62	2	25.167.0253.0	25.167.3253.0	25.177.0253.0	25.166.0253.0
100	23.71	15.24	3	25.167.0353.0	25.167.3353.0	25.177.0353.0	25.166.0353.0
4 to 24 pole on request							

wiecon

with insulating plate with locating cams

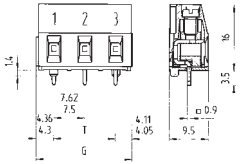

Drilling plan for versions with locating cams

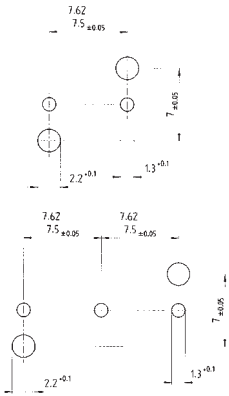

with insulating plate horizontal

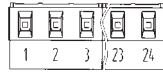
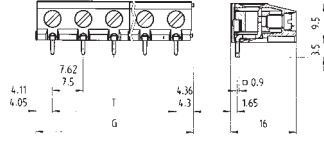

Solder pin 0.9 x 0.9 mm
Drill hole Ø 1.3 mm

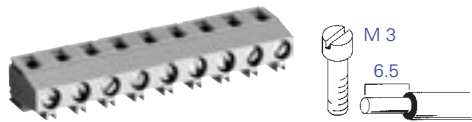

Type 8391 ZW/8491 ZW
Conductor vertical to PCB

No. 22 – 12 AWG 300 V 20/30 A
No. 22 – 12 AWG 300 V 25 A



Part No.	Part No.	Part No.	Part No.
marked with insulating plate without locating cams	marked with insulating plate with locating cams	unmarked with insulating plate horizontal	marked with insulating plate horizontal
25.164.3253.0	25.174.0253.0	25.165.6253.0	25.164.6253.0
25.164.3353.0	25.174.0353.0	25.165.6353.0	25.164.6353.0
marked with insulating plate without locating cams	marked with insulating plate with locating cams	unmarked with insulating plate horizontal	marked with insulating plate horizontal
25.166.3253.0	25.176.0253.0	25.167.6253.0	25.166.6253.0
25.166.3353.0	25.176.0353.0	25.167.6353.0	25.166.6353.0

PCB terminal, TOP spring clamp, pitch 5.00/5.08 mm

wiecon PCB

Rated cross section:
1.5 mm²

Rated current:
16 A

(based on ambient temperature 20 °C rated cross section and max. number of poles)

Wire range:
0.50 – 2.5 mm² single core/
0.50 – 1.5 mm² finely stranded

250 V/4 kV/3 – overvoltage category III

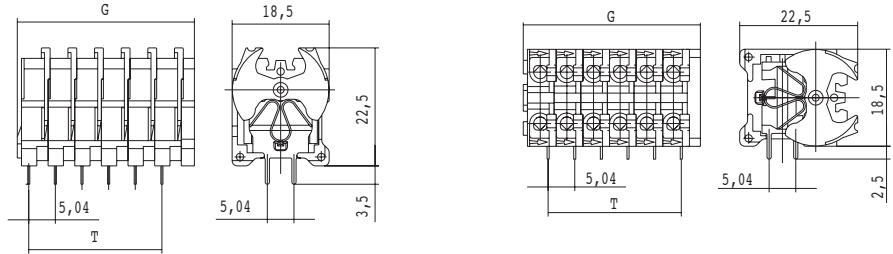

Solder pin 0.8 x 0.4 mm
Drill hole Ø 1.3 mm



Solder pin 0.8 x 0.4 mm
Drill hole Ø 1.3 mm

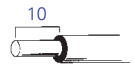

Type 8152 TOP V

Type 8152 TOP H

Rated voltages VDE 0110
UL Data
CSA Data
Approvals

field wiring

No. 26 – 14 AWG
No. 22 – 14 AWG

300 V 10 A
300 V 10 A

No. 26 – 14 AWG
No. 22 – 14 AWG

300 V 10 A
300 V 10 A

	Box Qty	G	T	Pole	Part No.	Part No.
pitch 5.00 mm						
	100	8.34	5.04	1	27.720.0153.0	27.730.0153.0
	100	13.38	10.08	2	27.720.0253.0	27.730.0253.0
	100	18.42	15.12	3	27.720.0353.0	27.730.0353.0
	50	23.46	20.16	4	27.720.0453.0	27.730.0453.0
	50	28.50	25.20	5	27.720.0553.0	27.730.0553.0
	50	33.54	30.24	6	27.720.0653.0	27.730.0653.0
	50	38.58	35.28	7	27.720.0753.0	27.730.0753.0
	50	43.62	40.32	8	27.720.0853.0	27.730.0853.0
	50	48.66	45.30	9	27.720.0953.0	27.730.0953.0
	50	53.70	50.40	10	27.720.1053.0	27.730.1053.0

PCB terminal, TOP connection system, pitch 5.00/5.08 mm

wiecon

Rated cross section:
2.5 mm²

Rated current:
16 A

Wire range:
0.14 – 4.0 mm² single core/
0.14 – 2.5 mm² finely stranded

250 V/4 kV/3 – overvoltage category III
*690 V/4 kV/2 – overvoltage category II
1000 V/4 kV/1 – overvoltage category I

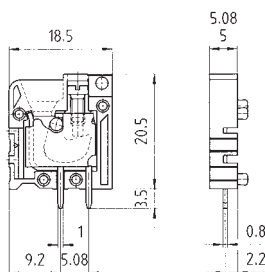

Materials
Insulating housing: PA 66/6 grey, UL 94-V0
Clamping part: galvanised steel
Contact and solder pin: tin plated E-Cu
Clamp: galvanised steel
Clamping screw: galvanised steel

* max. 600 V for non-earthed systems or expected overvoltage
≤ 4 kV

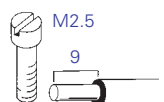

Solder pin 0.8 x 1.0 mm
Drill hole Ø 1.3 mm

Rated voltages VDE 0110
UL Data
CSA Data
Approvals

field-/factory wiring

Type 8185 TOP V

Conductor vertical to PCB
No. 22/30 – 12 AWG
No. 22 – 12 AWG

300 V 20/25 A
300 V 20 A



Type 8285 TOP V



Terminal block	Type	Part No.	Box Qty	Type	Part No.	Box Qty	
	pitch 5.00 mm			pitch 5.08 mm			
2 pole	8185 TOP V	25.741.0253.0	100	8285 TOP V	25.751.0253.0	100	
3 pole	8185 TOP V	25.741.0353.0	100	8285 TOP V	25.751.0353.0	100	
4 pole	8185 TOP V	25.741.0453.0	50	8285 TOP V	25.751.0453.0	50	
5 pole	8185 TOP V	25.741.0553.0	50	8285 TOP V	25.751.0553.0	50	
6 pole	8185 TOP V	25.741.0653.0	50	8285 TOP V	25.751.0653.0	50	
7 pole	8185 TOP V	25.741.0753.0	50	8285 TOP V	25.751.0753.0	50	
8 pole	8185 TOP V	25.741.0853.0	50	8285 TOP V	25.751.0853.0	50	
9 pole	8185 TOP V	25.741.0953.0	50	8285 TOP V	25.751.0953.0	50	
10 pole	8185 TOP V	25.741.1053.0	50	8285 TOP V	25.751.1053.0	50	
11 pole	8185 TOP V	25.741.1153.0	50	8285 TOP V	25.751.1153.0	50	
12 pole	8185 TOP V	25.741.1253.0	50	8285 TOP V	25.751.1253.0	50	
13 pole	8185 TOP V	25.741.1353.0	50	8285 TOP V	25.751.1353.0	50	
14 pole	8185 TOP V	25.741.1453.0	50	8285 TOP V	25.751.1453.0	50	
15 pole	8185 TOP V	25.741.1553.0	50	8285 TOP V	25.751.1553.0	50	
16 pole	8185 TOP V	25.741.1653.0	50	8285 TOP V	25.751.1653.0	50	
Individual poles connected in series							
Pitch 5.00 and 5.08 mm	1 pole	8185 TOP V	25.741.0053.0	100	8285 TOP V	25.751.0053.0	100
End plate		AP 8385 TOP N	07.300.4753.0	50	AP 8385 TOP N	07.300.4753.0	50
Marker tag holder, snap-on	1 pole		04.242.4253.0	100		04.242.4253.0	100
Marker tag holder, snap-on, for group marking, overall width 5.00 mm		BZ 8185 TOP N	04.242.5853.0	50			
Marking strips	unmarked	9705 A/5/10	04.242.5053.0	25			
	¹⁾ marked	9705 A/5/10 B	04.842.5053.0	25			
Marking branch	Labelled 1, 2, 3 ... 0	9704 A/1-0 B	04.841.2150.0	25			
Single tag	unmarked	9705 A	04.242.0800.0				
	¹⁾ marked	9705 AB	04.842.0850.0	500			
Adhesive marking strips	1 – 12 (100 x)		04.007.4089.0	1			
	13 – 24 (100 x)		04.007.4189.0	1			
¹⁾ Labelling on request							

PCB terminal, TOP connection system, pitch 5.00/5.08 mm

wiecon PCB

Rated cross section:
2.5 mm²

Rated current:
16 A

Wire range:
0.14 – 4.0 mm² single core/
0.14 – 2.5 mm² finely stranded

250 V/4 kV/3 – overvoltage category III
*690 V/4 kV/2 – overvoltage category II
1000 V/4 kV/1 – overvoltage category I

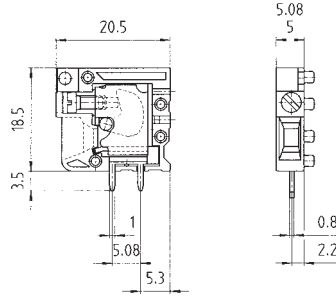

Materials
Insulating housing: PA 66/6 grey, UL 94-V0
Clamping part: galvanised steel
Contact and solder pin: tin plated E-Cu
Clamp: galvanised steel
Clamping screw: galvanised steel

* max. 600 V for non-earthed systems or expected overvoltage
≤ 4 kV

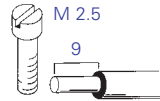

Solder pin 0.8 x 1.0 mm
Drill hole Ø 1.3 mm

Rated voltages VDE 0110
UL Data
CSA Data
Approvals

field/factory wiring

Type 8185 TOP H

Conductor horizontal to PCB
No. 22/30 – 12 AWG 300 V 20/25 A
No. 22 – 12 AWG 300 V 20 A



Type 8285 TOP H

Terminal block	Type	Part No.	Box Qty	Type	Part No.	Box Qty	
	pitch 5.00 mm			pitch 5.08 mm			
2 pole	8185 TOP H	25.741.3253.0	100	8285 TOP H	25.751.3253.0	100	
3 pole	8185 TOP H	25.741.3353.0	100	8285 TOP H	25.751.3353.0	100	
4 pole	8185 TOP H	25.741.3453.0	50	8285 TOP H	25.751.3453.0	50	
5 pole	8185 TOP H	25.741.3553.0	50	8285 TOP H	25.751.3553.0	50	
6 pole	8185 TOP H	25.741.3653.0	50	8285 TOP H	25.751.3653.0	50	
7 pole	8185 TOP H	25.741.3753.0	50	8285 TOP H	25.751.3753.0	50	
8 pole	8185 TOP H	25.741.3853.0	50	8285 TOP H	25.751.3853.0	50	
9 pole	8185 TOP H	25.741.3953.0	50	8285 TOP H	25.751.3953.0	50	
10 pole	8185 TOP H	25.741.4053.0	50	8285 TOP H	25.751.4053.0	50	
11 pole	8185 TOP H	25.741.4153.0	50	8285 TOP H	25.751.4153.0	50	
12 pole	8185 TOP H	25.741.4253.0	50	8285 TOP H	25.751.4253.0	50	
13 pole	8185 TOP H	25.741.4353.0	50	8285 TOP H	25.751.4353.0	50	
14 pole	8185 TOP H	25.741.4453.0	50	8285 TOP H	25.751.4453.0	50	
15 pole	8185 TOP H	25.741.4553.0	50	8285 TOP H	25.751.4553.0	50	
16 pole	8185 TOP H	25.741.4653.0	50	8285 TOP H	25.751.4653.0	50	
Individual poles connected in series							
Pitch 5.00 and 5.08 mm	1 pole	8185 TOP H	25.741.0153.0	100	8285 TOP H	25.751.0153.0	100
End plate		AP 8385 TOP N	07.300.4753.0	50	AP 8385 TOP N	07.300.4753.0	50
Marker tag holder, snap-on	1 pole		04.242.4253.0	100		04.242.4253.0	100
Marker tag holder, snap-on, for group marking, overall width 5.00 mm		BZ 8185 TOP N	04.242.5853.0	50			
Marking strips	unmarked	9705 A/5/10	04.242.5053.0	25			
	¹⁾ marked	9705 A/5/10 B	04.842.5053.0	25			
Marking branch	Labelled 1, 2, 3 ... 0	9704 A/1-0 B	04.841.2150.0	25			
Single tag	unmarked	9705 A	04.242.0850.0	500			
	¹⁾ marked	9705 AB	04.842.0850.0	500			
Adhesive marking strips	1 – 12 (100 x)		04.007.4089.0	1			
	13 – 24 (100 x)		04.007.4189.0	1			
¹⁾ Labelling on request							



PCB terminal, TOP connection system, pitch 7.50/7.62 mm



Rated cross section:
2.5 mm²

Rated current:
16 A

Wire range:
0.14 – 4.0 mm² single core/
0.14 – 2.5 mm² finely stranded

400 V/6 kV/3 – overvoltage category III
1000 V/6 kV/2 – overvoltage category II
1000 V/6 kV/1 – overvoltage category I

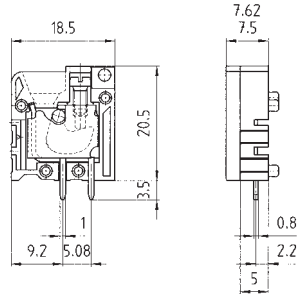

Materials
Insulating housing: PA 66/6 grey, UL 94-V0
Clamping part: galvanised steel
Contact and solder pin: tin plated E-Cu
Clamp: galvanised steel
Clamping screw: galvanised steel

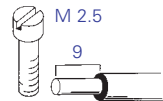
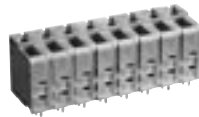

Solder pin 0.8 x 1.0 mm
Drill hole Ø 1.3 mm

Rated voltages VDE 0110
UL Data
CSA Data
Approvals

field-/factory wiring

Type 8385 TOP V

Conductor vertical to PCB
No. 22/30 – 12 AWG
No. 22 – 12 AWG



300 V 20/25 A
300 V 20 A

Type 8485 TOP V

No. 22/30 – 12 AWG
No. 22 – 12 AWG



300 V 20/25 A
300 V 20 A

Terminal block	Type	Part No.	Box Qty	Type	Part No.	Box Qty	
	pitch 7.50 mm			pitch 7.62 mm			
2 pole	8385 TOP V	25.761.0253.0	100	8485 TOP V	25.771.0253.0	100	
3 pole	8385 TOP V	25.761.0353.0	100	8485 TOP V	25.771.0353.0	100	
4 pole	8385 TOP V	25.761.0453.0	50	8485 TOP V	25.771.0453.0	50	
5 pole	8385 TOP V	25.761.0553.0	50	8485 TOP V	25.771.0553.0	50	
6 pole	8385 TOP V	25.761.0653.0	50	8485 TOP V	25.771.0653.0	50	
7 pole	8385 TOP V	25.761.0753.0	50	8485 TOP V	25.771.0753.0	50	
8 pole	8385 TOP V	25.761.0853.0	50	8485 TOP V	25.771.0853.0	50	
Pole numbers can be latched together on request							
Individual poles connected in series							
Pitch 7.50 and 7.62 mm	1 pole	8385 TOP V	25.761.0053.0	100	8485 TOP V	25.771.0053.0	100
End plate		AP 8385 TOP N	07.300.4753.0	50	AP 8385 TOP N	07.300.4753.0	50
Marker tag holder, snap-on	1 pole		04.242.4253.0	100		04.242.4253.0	100
Marker tag holder, snap-on, for group marking, overall width 5.00 mm		BZ 8185 TOP N	04.242.5853.0	50			
Marking strips	unmarked	9705 A/7,5/10	04.242.7553.0	25			
	¹⁾ marked	9705 A/7,5/10 B	04.842.7553.0	25			
Marking branch	Labelled 1, 2, 3 ... 0	9704 A/1-0 B	04.841.2150.0	25			
Single tag	unmarked	9705 A	04.242.0850.0	500			
	¹⁾ marked	9705 AB	04.842.0850.0	500			
Adhesive marking strips							
¹⁾ Labelling on request							

PCB terminal, TOP connection system, pitch 7.50/7.62 mm

wiecon PCB

Rated cross section:
2.5 mm²

Rated current:
16 A

Wire range:
0.14 – 4.0 mm² single core/
0.14 – 2.5 mm² finely stranded

400 V/6 kV/3 – overvoltage category III
1000 V/6 kV/2 – overvoltage category II
1000 V/6 kV/1 – overvoltage category I

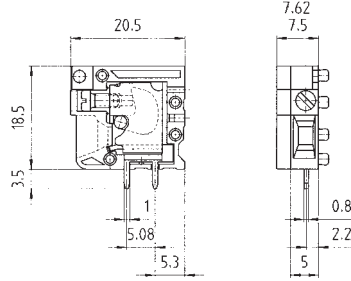

Materials
Insulating housing: PA 66/6 grey, UL 94-V0
Clamping part: galvanised steel
Contact and solder pin: tin plated E-Cu
Clamp: galvanised steel
Clamping screw: galvanised steel

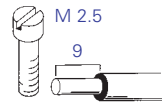

Solder pin 0.8 x 1.0 mm
Drill hole Ø 1.3 mm

Rated voltages VDE 0110
UL Data
CSA Data
Approvals

field-/factory wiring

Type 8385 TOP H

Conductor horizontal to PCB
No. 22/30 – 12 AWG 300 V 20/25 A
No. 22 – 12 AWG 300 V 20 A



Type 8485 TOP H



Terminal block	Type	Part No.	Box Qty	Type	Part No.	Box Qty	
	pitch 7.50 mm			pitch 7.62 mm			
2 pole	8385 TOP H	25.761.3253.0	100	8485 TOP H	25.771.3253.0	100	
3 pole	8385 TOP H	25.761.3353.0	100	8485 TOP H	25.771.3353.0	100	
4 pole	8385 TOP H	25.761.3453.0	50	8485 TOP H	25.771.3453.0	50	
5 pole	8385 TOP H	25.761.3553.0	50	8485 TOP H	25.771.3553.0	50	
6 pole	8385 TOP H	25.761.3653.0	50	8485 TOP H	25.771.3653.0	50	
7 pole	8385 TOP H	25.761.3753.0	50	8485 TOP H	25.771.3753.0	50	
8 pole	8385 TOP H	25.761.3853.0	50	8485 TOP H	25.771.3853.0	50	
Individual poles connected in series							
Pitch 5.00 and 5.08 mm	1 pole	8385 TOP H	25.761.0153.0	100	8485 TOP H	25.771.0153.0	100
End plate		AP 8385 TOP N	07.300.4753.0	50	AP 8385 TOP N	07.300.4753.0	50
Marker tag holder, snap-on	1 pole		04.242.4253.0	100		04.242.4253.0	100
Marker tag holder, snap-on, for group marking, overall width 5.00 mm		BZ 8185 TOP N	04.242.5853.0	50			
Marking strips	unmarked	9705 A/7,5/10	04.242.7553.0	25			
	¹⁾ marked	9705 A/7,5/10 B	04.842.7553.0	25			
Marking branch	Labelled 1, 2, 3 ... 0	9704 A/1-0 B	04.841.2150.0	25			
Single tag	unmarked	9705 A	04.242.0850.0	500			
	¹⁾ marked	9705 AB	04.842.0850.0	500			
Adhesive marking strips							
¹⁾ Labelling on request							

PCB terminal, spring clamp system pitch 5.00/5.08 mm

Rated cross section:
2.5 mm²

Rated current:
16 A

Wire range:
0.14 – 4.0 mm² single core/
0.14 – 2.5 mm² finely stranded

250 V/4 kV/3 – overvoltage category III
*690 V/4 kV/2 – overvoltage category II
1000 V/4 kV/1 – overvoltage category I

Materials
Insulating housing: PA 66/6 grey, UL 94-V0
Clamping part: nickel plated brass
Contact and solder pin: tin plated E-Cu

* max. 600 V for non-earthed systems or
expected overvoltage ≤ 4 kV

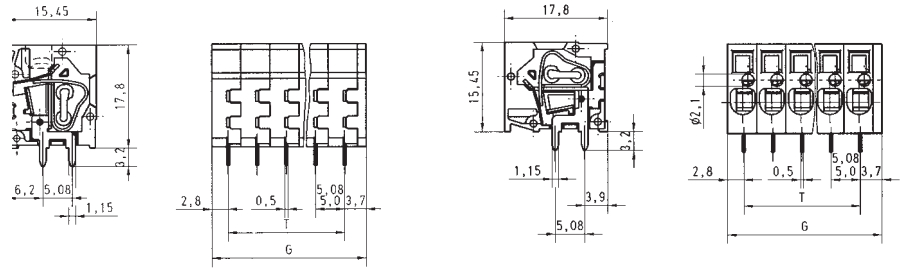

Solder pin 0.5 x 1.15 mm
Drill hole Ø 1.3 mm



Solder pin 0.5 x 1.15 mm
Drill hole Ø 1.3 mm



Type 8158 TOP V

Conductor vertical to PCB
No. 22/30 – 12 AWG
No. 22 – 12 AWG

8258 TOP V

Type 8158 TOP H

Conductor horizontal to PCB
No. 22/30 – 12 AWG
No. 22 – 12 AWG

8258 TOP H

Rated voltages VDE 0110
UL Data
CSA Data
Approvals in preparation
field/factory wiring

pitch 5.00 mm		Type	Part No.	Box Qty	Type	Part No.	Box Qty
2 pole	8158 TOP V	25.780.0253.0	100	8158 TOP H	25.790.0253.0	100	
	8158 TOP V	25.780.0353.0	100	8158 TOP H	25.790.0353.0	100	
	8158 TOP V	25.780.0453.0	50	8158 TOP H	25.790.0453.0	50	
5 pole	8158 TOP V	25.780.0553.0	50	8158 TOP H	25.790.0553.0	50	
	8158 TOP V	25.780.0653.0	50	8158 TOP H	25.790.0653.0	50	
	8158 TOP V	25.780.0753.0	50	8158 TOP H	25.790.0753.0	50	
8 pole	8158 TOP V	25.780.0853.0	50	8158 TOP H	25.790.0853.0	50	
	8158 TOP V	25.780.0953.0	50	8158 TOP H	25.790.0953.0	50	
	8158 TOP V	25.780.1053.0	50	8158 TOP H	25.790.1053.0	50	
11 pole	8158 TOP V	25.780.1153.0	50	8158 TOP H	25.790.1153.0	50	
	8158 TOP V	25.780.1253.0	50	8158 TOP H	25.790.1253.0	50	
	8158 TOP V	25.780.1353.0	50	8158 TOP H	25.790.1353.0	50	
Larger pole combinations on request	14 pole	8158 TOP V	25.780.1453.0	50	8158 TOP H	25.790.1453.0	50
	15 pole	8158 TOP V	25.780.1553.0	50	8158 TOP H	25.790.1553.0	50
	16 pole	8158 TOP V	25.780.1653.0	50	8158 TOP H	25.790.1653.0	50
pitch 5.08 mm							
2 pole	8258 TOP V	25.781.0253.0	100	8258 TOP H	25.791.0253.0	100	
	8258 TOP V	25.781.0353.0	100	8258 TOP H	25.791.0353.0	100	
	8258 TOP V	25.781.0453.0	50	8258 TOP H	25.791.0453.0	50	
5 pole	8258 TOP V	25.781.0553.0	50	8258 TOP H	25.791.0553.0	50	
	8258 TOP V	25.781.0653.0	50	8258 TOP H	25.791.0653.0	50	
	8258 TOP V	25.781.0753.0	50	8258 TOP H	25.791.0753.0	50	
8 pole	8258 TOP V	25.781.0853.0	50	8258 TOP H	25.791.0853.0	50	
	8258 TOP V	25.781.0953.0	50	8258 TOP H	25.791.0953.0	50	
	8258 TOP V	25.781.1053.0	50	8258 TOP H	25.791.1053.0	50	
11 pole	8258 TOP V	25.781.1153.0	50	8258 TOP H	25.791.1153.0	50	
	8258 TOP V	25.781.1253.0	50	8258 TOP H	25.791.1253.0	50	
	8258 TOP V	25.781.1353.0	50	8258 TOP H	25.791.1353.0	50	
Larger pole combinations on request	14 pole	8258 TOP V	25.781.1453.0	50	8258 TOP H	25.791.1453.0	50
	15 pole	8258 TOP V	25.781.1553.0	50	8258 TOP H	25.791.1553.0	50
	16 pole	8258 TOP V	25.781.1653.0	50	8258 TOP H	25.791.1653.0	50
Accessories							
Adhesive marking strips	1 – 12 (100 x)	04.007.4089.0	1	04.007.4089.0	1		
	13 – 24 (100 x)	04.007.4189.0	1	04.007.4189.0	1		
Labelling on request							
Test plug		Z5.553.2921.0	10	Z5.553.2921.0	10		

PCB terminal, spring clamp system pitch 7.50/7.62 mm

wiecon PCB

Rated cross section:
2.5 mm²

Rated current:
16 A

Wire range:
0.14 – 4.0 mm² single core/
0.14 – 2.5 mm² finely stranded

400 V/6 kV/3 – overvoltage category III
1000 V/6 kV/2 – overvoltage category II
1000 V/6 kV/1 – overvoltage category I

Materials
Insulating housing: PA 66/6 grey, UL 94-V0
Clamping part: nickel plated brass
Contact and solder pin: tin plated E-Cu

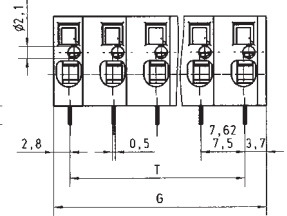
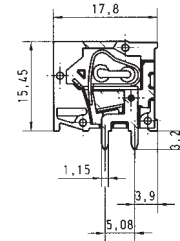
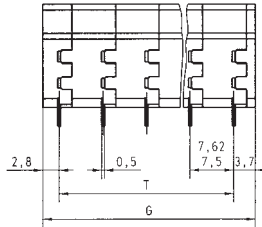
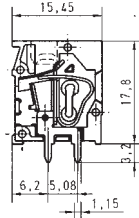

Solder pin 0.5 x 1.15 mm
Drill hole Ø 1.3 mm



Solder pin 0.5 x 1.15 mm
Drill hole Ø 1.3 mm



Type 8358 TOP V

Conductor vertical to PCB
No. 22/30 – 12 AWG
No. 22 – 12 AWG

8458 TOP V

Type 8358 TOP H

Conductor horizontal to PCB
No. 22/30 – 12 AWG
No. 22 – 12 AWG

8458 TOP H

Rated voltages VDE 0110

UL Data

CSA Data

Approvals in preparation

field-/factory wiring

pitch 7.50 mm		Type	Part No.	Box Qty	Type	Part No.	Box Qty
2 pole	8358 TOP V	25.782.0253.0	100	8358 TOP H	25.792.0253.0	100	
	8358 TOP V	25.782.0353.0	100	8358 TOP H	25.792.0353.0	100	
	8358 TOP V	25.782.0453.0	50	8358 TOP H	25.792.0453.0	50	
5 pole	8358 TOP V	25.782.0553.0	50	8358 TOP H	25.792.0553.0	50	
	8358 TOP V	25.782.0653.0	50	8358 TOP H	25.792.0653.0	50	
	8358 TOP V	25.782.0753.0	50	8358 TOP H	25.792.0753.0	50	
8 pole	8358 TOP V	25.782.0853.0	50	8358 TOP H	25.792.0853.0	50	
	8358 TOP V	25.782.0953.0	50	8358 TOP H	25.792.0953.0	50	
	8358 TOP V	25.782.1053.0	50	8358 TOP H	25.792.1053.0	50	
11 pole	8358 TOP V	25.782.1153.0	50	8358 TOP H	25.792.1153.0	50	
	8358 TOP V	25.782.1253.0	50	8358 TOP H	25.792.1253.0	50	
	8358 TOP V	25.782.1353.0	50	8358 TOP H	25.792.1353.0	50	
14 pole	8358 TOP V	25.782.1453.0	50	8358 TOP H	25.792.1453.0	50	
	8358 TOP V	25.782.1553.0	50	8358 TOP H	25.792.1553.0	50	
	8358 TOP V	25.782.1653.0	50	8358 TOP H	25.792.1653.0	50	
Larger pole combinations on request							
pitch 7.62 mm							
2 pole	8458 TOP V	25.783.0253.0	100	8458 TOP H	25.793.0253.0	100	
	8458 TOP V	25.783.0353.0	100	8458 TOP H	25.793.0353.0	100	
	8458 TOP V	25.783.0453.0	50	8458 TOP H	25.793.0453.0	50	
5 pole	8458 TOP V	25.783.0553.0	50	8458 TOP H	25.793.0553.0	50	
	8458 TOP V	25.783.0653.0	50	8458 TOP H	25.793.0653.0	50	
	8458 TOP V	25.783.0753.0	50	8458 TOP H	25.793.0753.0	50	
8 pole	8458 TOP V	25.783.0853.0	50	8458 TOP H	25.793.0853.0	50	
	8458 TOP V	25.783.0953.0	50	8458 TOP H	25.793.0953.0	50	
	8458 TOP V	25.783.1053.0	50	8458 TOP H	25.793.1053.0	50	
11 pole	8458 TOP V	25.783.1153.0	50	8458 TOP H	25.793.1153.0	50	
	8458 TOP V	25.783.1253.0	50	8458 TOP H	25.793.1253.0	50	
	8458 TOP V	25.783.1353.0	50	8458 TOP H	25.793.1353.0	50	
14 pole	8458 TOP V	25.783.1453.0	50	8458 TOP H	25.793.1453.0	50	
	8458 TOP V	25.783.1553.0	50	8458 TOP H	25.793.1553.0	50	
	8458 TOP V	25.783.1653.0	50	8458 TOP H	25.793.1653.0	50	
Larger pole combinations on request							
Accessories							
Labelling on request							
Test plug		Z5.553.2921.0	10		Z5.553.2921.0	10	

PCB terminal, TOP connection system pitch 6.35 mm



Rated cross section:
4.0 mm²

Rated current:
36 A

(based on ambient temperature 20 °C rated cross section and max. number of poles)

Wire range:

0.5 – 6.0 mm² single core/
0.5 – 4.0 mm² finely stranded

320 V/4 kV/3 – overvoltage category III
320 V/4 kV/2 – overvoltage category II
320 V/4 kV/1 – overvoltage category I

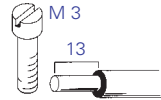
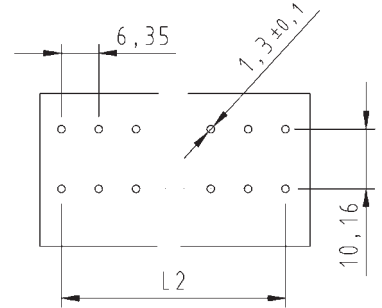
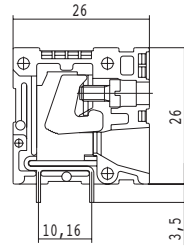
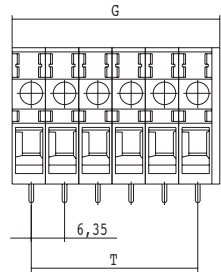

Solder pin Ø 0.8 x 0.9 mm
Drill hole Ø 1.3 mm

Type 7386 TOP H

Rated voltages VDE 0110

UL Data

CSA Data

Approvals

field wiring

No. 22 – 10 AWG

300 V 30 A

No. 22 – 10 AWG

300 V 30 A

Box Qty	G	T	Pole	Part No.
pitch 6.35 mm				
50	14.20	6.35	2	27.714.0253.0
50	20.55	12.70	3	27.714.0353.0
50	26.90	19.05	4	27.714.0453.0
50	33.25	25.40	5	27.714.0553.0
50	39.60	31.75	6	27.714.0653.0
50	45.95	38.10	7	27.714.0753.0
50	52.30	44.45	8	27.714.0853.0

PCB terminal, TOP connection system pitch 7.62 mm

wiecon PCB

Rated cross section:
4.0 mm²

Rated current:
36 A

(based on ambient 20°C, rated cross section and max. number of poles)

Wire range:
0.5 – 6.0 mm² single core/
0.5 – 4.0 mm² finely stranded

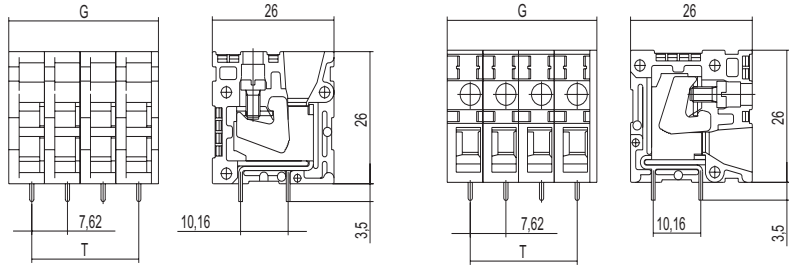

500 V/4 kV/3 – Overvoltage category III
630 V/4 kV/2 – Overvoltage category II
1000 V/4 kV/1 – Overvoltage category I



Solder pin 0.8 x 0.9 mm
Drill hole Ø 1.3 mm



Solder pin 0.8 x 0.9 mm
Drill hole Ø 1.3 mm

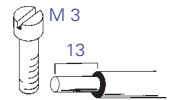

8486 TOP V

8486 TOP H

Rated voltages VDE 0110

UL Data

CSA Data

Approvals

field wiring

No. 22 – 10 AWG

300 V

30 A

No. 22 – 10 AWG

300 V

30 A



No. 22 – 10 AWG

300 V

30 A

No. 22 – 10 AWG

300 V

30 A



	Box Qty	G	T	Pole	Part No.	Part No.
pitch 7.62 mm					unmarked	unmarked
	50	16.74	7.62	2	27.703.0253.0	27.713.0253.0
	50	24.36	15.24	3	27.703.0353.0	27.713.0353.0
	50	31.98	22.86	4	27.703.0453.0	27.713.0453.0

Accessories

wiecon

Test plugs and marker holder 8191 E / 8191 D / 8291 E / 8291 can only be used in the upper tier

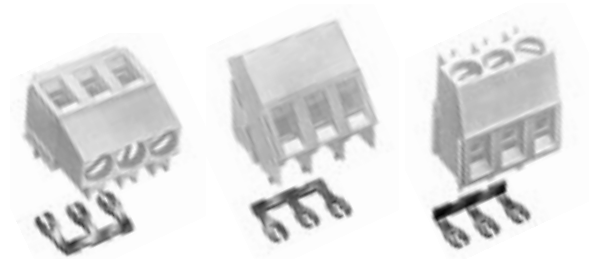



- 2 to 24 pole connecting comb for pitch 5.00 and 5.08 mm available on request
- PCB terminals with assembled connecting comb available on request



Type 8191 / 8191 E / 8191 D / 8192 Type 8291 / 8291 E / 8291 D

Type 8391/8491

Type 8135 / 8235 Type 8191 ZW / 8291 ZW / 8192

Pole	Part No.	Box Qty	Pole	Part No.	Box Qty	Pole	Part No.	Box Qty
1	Test plug Z5.533.7121.0	100	1	Test plug Z5.533.7121.0	100	1	Test plug Z5.533.7121.0	100
2	Z5.533.7221.0	100	2	Z5.533.8221.0	50	2	Z5.533.7221.0	100
1	Test plug 1pole pitch 10 mm Z5.533.7121.0	100				1	Test plug 1 pole pitch 10 mm Z5.533.7121.0	100
	Marker tag carrier for 12 pole, can be divided for smaller pole numbers 04.242.4653.0	50					Marker tag carrier for 12 pole, can be divided for smaller pole numbers 04.242.4653.0	50
	Marker strips unmarked 04.242.5053.0	25					Marker strips unmarked 04.242.5053.0	25
	Marked 1 – 10, 11 – 20 etc. 991 – 999 04.842.5053.0	25					Marked 1 – 10, 11 – 20 etc. 991 – 999 04.842.5053.0	25
	Marking branch, labelled 1, 2, 3 ... 0 04.841.2150.0	25					Marking branch labelled 1, 2, 3 ... 0 04.841.2150.0	25
	Single tag, unmarked 04.242.0850.0	500					Single tag, unmarked 04.242.0850.0	500
	Marked 04.842.0850.0	500					Marked 04.842.0850.0	500
								
	Adhesive marking strips (1 sheet = 100 strips)			Adhesive marking strips (1 sheet = 100 strips)			Adhesive marking strips (1 sheet = 100 strips)	
	1 – 12	04.007.4089.0	1	1 – 12	04.007.4089.0	1	1 – 12	04.007.4089.0
	13 – 24	04.007.4189.0	1	13 – 24	04.007.4189.0	1	13 – 24	04.007.4189.0
	25 – 36	04.007.4289.0	1	25 – 36	04.007.4289.0	1	25 – 36	04.007.4289.0
	37 – 48	04.007.4389.0	1	37 – 48	04.007.4389.0	1	37 – 48	04.007.4389.0
	49 – 60	04.007.4489.0	1	49 – 60	04.007.4489.0	1	49 – 60	04.007.4489.0
	61 – 72	04.007.4589.0	1	61 – 72	04.007.4589.0	1	61 – 72	04.007.4589.0
	73 – 84	04.007.4689.0	1	73 – 84	04.007.4689.0	1	73 – 84	04.007.4689.0
	85 – 96	04.007.4789.0	1	85 – 96	04.007.4789.0	1	85 – 96	04.007.4789.0
	97 – 108	04.007.4889.0	1	97 – 108	04.007.4889.0	1	97 – 108	04.007.4889.0

PCB terminal, rising cage clamp system pitch 5.00/10.00 mm

wiecon PCB

Rated cross section:
2.5 mm²

Rated current:
16 A

Wire range:
0.14 – 4.0 mm² single core/
0.14 – 2.5 mm² finely stranded

250 V/4 kV/3 – Overvoltage category III
*690 V/4 kV/2 – Overvoltage category II
1000 V/4 kV/1 – Overvoltage category I

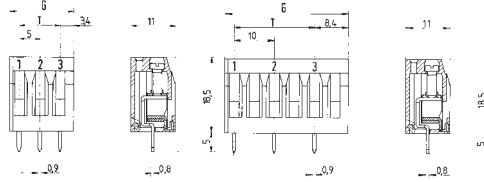

* max. 600 V for non-earthed systems or expected overvoltage
≤ 4 kV

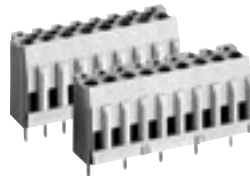

Solder pin 0.8 x 0.9 mm
Drill hole Ø 1.2 mm

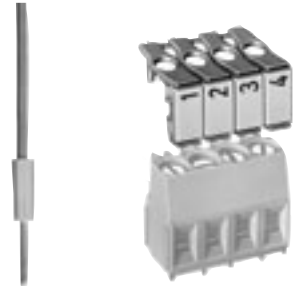
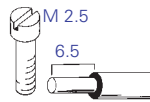

Type 8190
conductor horizontal to PCB

No. 22 – 12 AWG 300 V 15 A
No. 22 – 14 AWG 300 V 10 A



Accessories
Type 8190

Rated voltages VDE 0110 (pitch 5 mm)
UL Data
CSA Data
Approvals

Box Qty	G	T	Pole	Part No.	Part No.	Pole	Part No.	Box Qty	
pitch 5.00 mm									
100	10.86	5	2	unmarked	marked	1			
100	15.86	10	3	25.131.0253.0	25.130.0253.0	2	Test plug nominal current = 2 A	100	
50	20.86	15	4	25.131.0353.0	25.130.0353.0		Z5.543.0153.0	100	
				25.131.0453.0	25.130.0453.0		Z5.543.0253.0	100	
50	25.86	20	5	25.131.0553.0	25.130.0553.0		Marker tag carrier for 12 pole, can be divided for smaller pole numbers	50	
50	30.86	25	6	25.131.0653.0	25.130.0653.0		04.242.4653.0		
50	35.86	30	7	25.131.0753.0	25.130.0753.0		Marker strips unmarked	25	
50	40.86	35	8	25.131.0853.0	25.130.0853.0		04.242.5053.0		
50	45.86	40	9	25.131.0953.0	25.130.0953.0		Marked 1 – 10, 11 – 20 etc. 991 – 999	25	
50	50.86	45	10	25.131.1053.0	25.130.1053.0		04.842.5053.0		
50	55.86	50	11	25.131.1153.0	25.130.1153.0		Marking branch	25	
50	60.86	55	12	25.131.1253.0	25.130.1253.0		labelled 1, 2, 3 ... 0		
50	65.86	60	13	25.131.1353.0	25.130.1353.0		04.841.2150.0		
50	70.86	65	14	25.131.1453.0	25.130.1453.0		Single tag, unmarked	500	
50	75.86	70	15	25.131.1553.0	25.130.1553.0		04.242.0850.0		
50	80.86	75	16	25.131.1653.0	25.130.1653.0		Marked	500	
							04.842.0850.0		
17 to 24 pole on request									
pitch 10.00 mm									
50	20.86	10	2	unmarked	marked				
50	30.86	20	3	25.133.0253.0	25.132.0253.0				
50	40.86	30	4	25.133.0353.0	25.132.0353.0				
50	40.86	30	4	25.133.0453.0	25.132.0453.0				
50	50.86	40	5	25.133.0553.0	25.132.0553.0				
50	60.86	50	6	25.133.0653.0	25.132.0653.0				
50	70.86	60	7	25.133.0753.0	25.132.0753.0				
50	80.86	70	8	25.133.0853.0	25.132.0853.0				
50	90.86	80	9	25.133.0953.0	25.132.0953.0				
50	100.86	90	10	25.133.1053.0	25.132.1053.0				
50	110.86	100	11	25.133.1153.0	25.132.1153.0				
50	120.86	110	12	25.133.1253.0	25.132.1253.0				
Rated voltages (pitch 10.00 mm): VDE 0110				Materials					
690 V/8 kV/3 – Overvoltage category III				Insulating housing: PA 6/66, UL 94-V0					
1000 V/8 kV/2 – Overvoltage category II				Clamping part: galvanised steel					
1000 V/8 kV/1 – Overvoltage category I				Contact and solder pin: tin plated E-Cu					
				Clamping screw: galvanised steel					
							Adhesive marking strips (1 sheet = 100 strips)		
							1 – 12	04.007.4089.0	1
							13 – 24	04.007.4189.0	1
							25 – 36	04.007.4289.0	1
							37 – 48	04.007.4389.0	1
							49 – 60	04.007.4489.0	1
							61 – 72	04.007.4589.0	1
							73 – 84	04.007.4689.0	1
							85 – 96	04.007.4789.0	1
							97 – 108	04.007.4889.0	1

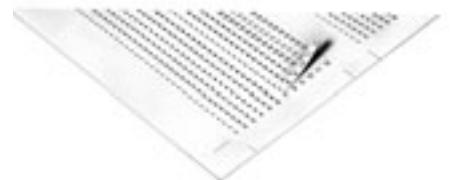

PCB terminal, rising cage clamp system pitch 7.50 mm



Rated cross section:
2.5 mm²

Rated current:
16 A

Wire range:
0.14 – 4.0 mm² single core/
0.14 – 2.5 mm² finely stranded

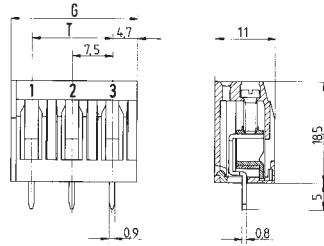

500 V/6 kV/3 – Overvoltage category III
1000 V/6 kV/2 – Overvoltage category II
1000 V/6 kV/1 – Overvoltage category I

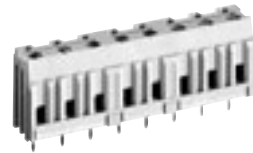

Solder pin 0.8 x 0.9 mm
Drill hole Ø 1.2 mm

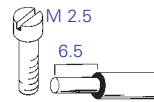

Type 8390
conductor horizontal to PCB

Rated voltages VDE 0110
UL Data
CSA Data
Approvals

No. 22 – 12 AWG 300 V 15 A
No. 22 – 14 AWG 300 V 10 A



Accessories
Type 8390

pitch 7.50 mm	Box Qty	G	T	Pole	Part No.	Part No.	Pole	Part No.	Box Qty
					unmarked	marked			
	100	15.86	7.5	2	25.151.0253.0	25.150.0253.0	1	Test plug nominal current = 2 A	
	100	23.36	15.0	3	25.151.0353.0	25.150.0353.0	2	Z5.543.0153.0	100
	50	30.86	22.5	4	25.151.0453.0	25.150.0453.0		Z5.543.0253.0	100
	50	38.36	30.0	5	25.151.0553.0	25.150.0553.0			
	50	45.86	37.5	6	25.151.0653.0	25.150.0653.0			
	50	53.36	45.0	7	25.151.0753.0	25.150.0753.0			
	50	60.86	52.5	8	25.151.0853.0	25.150.0853.0			
	50	68.36	60.0	9	25.151.0953.0	25.150.0953.0			
	50	75.86	67.5	10	25.151.1053.0	25.150.1053.0			
	50	83.36	75.0	11	25.151.1153.0	25.150.1153.0			
	50	90.86	82.5	12	25.151.1253.0	25.150.1253.0			
					Materials Insulating housing: PA 6/66, UL 94-V0 Clamping part: galvanised steel Contact and solder pin: tin plated E-Cu Clamping screw: galvanised steel				

PCB terminal, rising cage clamp system pitch 5.00/5.08 mm

wiecon PCB

Rated cross section:
1.5 mm²

Rated current:
10 A

Wire range:
0.14 – 2.5 mm² single core/
0.14 – 1.5 mm² finely stranded

250 V/4 kV/3 – Overvoltage category III
*690 V/4 kV/2 – Overvoltage category II
1000 V/4 kV/1 – Overvoltage category I

without insulating plate

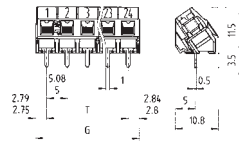

with insulating plate, without locating cams

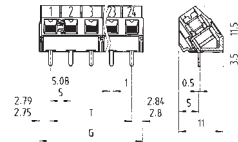

Drilling plan for version with locating cams

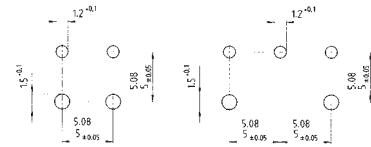

* max. 600 V for non-earthed systems or expected overvoltage
≤ 4 kV

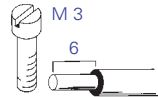

Solder pin 0.5 x 1.0 mm
Drill hole Ø 12 mm

Type 8134/8234

Conductor at 35° to PCB

Rated voltages VDE 0110

UL Data

field/factory wiring

CSA Data

Approvals

No. 30 – 14 AWG

300 V 15/16 A

No. 30 – 14 AWG

300 V 15 A



Box Qty	G	T	Pole	Part No.	Part No.	Part No.	Part No.
				unmarked without insulating plate	marked without insulating plate	unmarked with insulating plate with locating cams	marked with locating cams
pitch 5.00 mm							
100	10.55	5	2	25.501.0253.0	25.500.0253.0	25.501.6253.0	25.500.6253.0
100	15.55	10	3	25.501.0353.0	25.500.0353.0	25.501.6353.0	25.500.6353.0
50	20.55	15	4	25.501.0453.0	25.500.0453.0		
50	25.55	20	5	25.501.0553.0	25.500.0553.0		
50	30.55	25	6	25.501.0653.0	25.500.0653.0		
50	35.55	30	7	25.501.0753.0	25.500.0753.0		
50	40.55	35	8	25.501.0853.0	25.500.0853.0		
50	45.55	40	9	25.501.0953.0	25.500.0953.0		
50	50.55	45	10	25.501.1053.0	25.500.1053.0		
50	55.55	50	11	25.501.1153.0	25.500.1153.0		
50	60.55	55	12	25.501.1253.0	25.500.1253.0		
50	65.55	60	13	25.501.1353.0	25.500.1353.0		
50	70.55	65	14	25.501.1453.0	25.500.1453.0		
50	75.55	70	15	25.501.1553.0	25.500.1553.0		
50	80.55	75	16	25.501.1653.0	25.500.1653.0		
17 to 24 pole on request							
pitch 5.08 mm							
100	10.71	5.08	2	25.503.0253.0	25.502.0253.0	25.503.6253.0	25.502.6253.0
100	15.79	10.16	3	25.503.0353.0	25.502.0353.0	25.503.6353.0	25.502.6353.0
50	20.87	15.24	4	25.503.0453.0	25.502.0453.0		
50	25.95	20.32	5	25.503.0553.0	25.502.0553.0		
50	31.03	25.40	6	25.503.0653.0	25.502.0653.0		
50	36.11	30.48	7	25.503.0753.0	25.502.0753.0		
50	41.19	35.56	8	25.503.0853.0	25.502.0853.0		
50	46.27	40.64	9	25.503.0953.0	25.502.0953.0		
50	51.35	45.72	10	25.503.1053.0	25.502.1053.0		
50	56.42	50.80	11	25.503.1153.0	25.502.1153.0		
50	61.51	55.88	12	25.503.1253.0	25.502.1253.0		
50	66.59	60.96	13	25.503.1353.0	25.502.1353.0		
50	71.67	66.04	14	25.503.1453.0	25.502.1453.0		
50	76.75	71.12	15	25.503.1553.0	25.502.1553.0		
50	81.83	76.20	16	25.503.1653.0	25.502.1653.0		
17 to 24 pole on request							

wiecon

Materials

Insulating housing: PA 66/6 grey, UL 94-V0

Clamping part: nickel plated brass

Contact and solder pin: tin-plated bronze

Clamping screw: galvanised steel

Part No.	Part No.
unmarked with insulating plate without locating cams	marked with insulating plate with locating cams
on request	on request
on request	on request

PCB terminal, rising cage clamp system pitch 5.00/5.08 mm

wiecon PCB

Rated cross section:
2.5 mm²

Rated current:
16 A

Wire range:
0.14 – 4.0 mm² single core/
0.14 – 2.5 mm² finely stranded

250 V/4 kV/3 – Overvoltage category III
*690 V/4 kV/2 – Overvoltage category II
1000 V/4 kV/1 – Overvoltage category I

* max. 600 V for non-earthed systems or expected overvoltage
≤ 4 kV

Rated voltages VDE 0110

UL Data

CSA Data

Approvals

field/factory wiring

without insulating plate

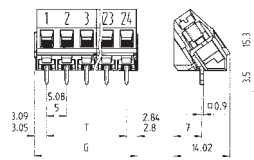

with insulating plate, without locating cams

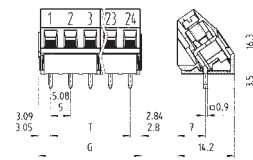

Drilling plan for version with locating cams

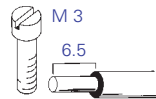
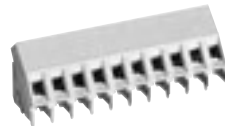
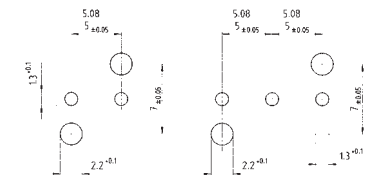

Solder pin 0.9 x 0.9 mm
Drill hole Ø 1.3 mm

Type 8135/8235

Conductor at 35° to PCB

No. 22 – 12 AWG

300 V 20/30 A

No. 22 – 12 AWG

300 V 25 A



Box Qty	G	T	Pole	Part No.	Part No.	Part No.	Part No.
				unmarked without insulating plate	marked without insulating plate	unmarked with insulating plate with locating cams	marked with insulating plate with locating cams
pitch 5.00 mm							
100	10.85	5	2	25.521.0253.0	25.520.0253.0	25.521.6253.0	25.520.6253.0
100	15.85	10	3	25.521.0353.0	25.520.0353.0	25.521.6353.0	25.520.6353.0
50	20.85	15	4	25.521.0453.0	25.520.0453.0		
50	25.85	20	5	25.521.0553.0	25.520.0553.0		
50	30.85	25	6	25.521.0653.0	25.520.0653.0		
50	35.85	30	7	25.521.0753.0	25.520.0753.0		
50	40.85	35	8	25.521.0853.0	25.520.0853.0		
50	45.85	40	9	25.521.0953.0	25.520.0953.0		
50	50.85	45	10	25.521.1053.0	25.520.1053.0		
50	55.85	50	11	25.521.1153.0	25.520.1153.0		
50	60.85	55	12	25.521.1253.0	25.520.1253.0		
50	65.85	60	13	25.521.1353.0	25.520.1353.0		
50	70.85	65	14	25.521.1453.0	25.520.1453.0		
50	75.85	70	15	25.521.1553.0	25.520.1553.0		
50	80.85	75	16	25.521.1653.0	25.520.1653.0		
17 to 24 pole on request							
pitch 5.08 mm							
100	11.01	5.08	2	25.523.0253.0	25.522.0253.0	25.523.6253.0	25.522.6253.0
100	16.09	10.16	3	25.523.0353.0	25.522.0353.0	25.523.6353.0	25.522.6353.0
50	21.17	15.24	4	25.523.0453.0	25.522.0453.0		
50	26.25	20.32	5	25.523.0553.0	25.522.0553.0		
50	31.33	25.40	6	25.523.0653.0	25.522.0653.0		
50	36.41	30.48	7	25.523.0753.0	25.522.0753.0		
50	41.49	35.56	8	25.523.0853.0	25.522.0853.0		
50	46.57	40.64	9	25.523.0953.0	25.522.0953.0		
50	51.65	45.72	10	25.523.1053.0	25.522.1053.0		
50	56.73	50.80	11	25.523.1153.0	25.522.1153.0		
50	61.81	55.88	12	25.523.1253.0	25.522.1253.0		
50	66.89	60.96	13	25.523.1353.0	25.522.1353.0		
50	71.97	66.04	14	25.523.1453.0	25.522.1453.0		
50	77.05	71.12	15	25.523.1553.0	25.522.1553.0		
50	82.13	76.20	16	25.523.1653.0	25.522.1653.0		
17 to 24 pole on request							

wiecon

with insulating plate, with locating cams

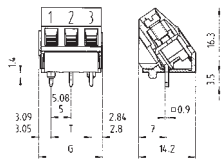

Materials

Insulating housing: PA 66/6 grey, UL 94-V0

Clamping part: nickel plated brass

Contact and solder pin: tin plated E-Cu

Clamping screw: galvanised steel

Part No.	Part No.
unmarked with insulating plate without locating cams	marked with insulating plate without locating cams
on request	on request
on request	on request

PCB terminal, rising cage clamp system pitch 5.00/5.08 mm

wiecon PCB

Rated cross section:
1.5 mm²

Rated current:
10 A

Wire range:
0.14 – 2.5 mm² single core/
0.14 – 1.5 mm² finely stranded

250 V/4 kV/3 – Overvoltage category III
*690 V/4 kV/2 – Overvoltage category II
1000 V/4 kV/1 – Overvoltage category I

without insulating plate

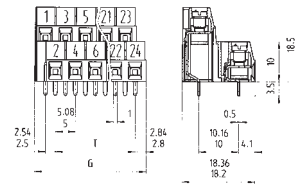

with insulating plate, without locating cams

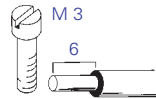
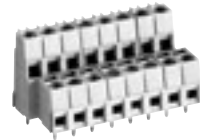
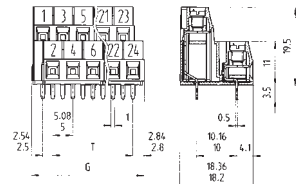

Solder pin 0.5 x 1.0 mm
Drill hole Ø 12 mm

* max. 600 V for non-earthed systems or expected overvoltage
≤ 4 kV

Type 8192 E/8292 E conductor horizontal to PCB

Rated voltages VDE 0110

UL Data

field/factory wiring

CSA Data

Approvals

No. 30 – 14 AWG

300 V 15/16 A

No. 30 – 14 AWG

300 V 15 A



Box Qty	G	T	Pole	Part No.	Part No.	Part No.	Part No.
				unmarked without insulating plate	marked without insulating plate	unmarked with insulating plate with locating cams	marked with insulating plate with locating cams
pitch 5.00 mm							
50	13.05	5	4	25.198.5253.0	25.198.0253.0	25.198.9253.0	25.198.4253.0
50	18.05	10	6	25.198.5353.0	25.198.0353.0	25.198.9353.0	25.198.4353.0
50	23.05	15	8	25.198.5453.0	25.198.0453.0		
50	28.05	20	10	25.198.5553.0	25.198.0553.0		
50	33.05	25	12	25.198.5653.0	25.198.0653.0		
50	38.05	30	14	25.198.5753.0	25.198.0753.0		
50	43.05	35	16	25.198.5853.0	25.198.0853.0		
50	48.05	40	18	25.198.5953.0	25.198.0953.0		
50	53.05	45	20	25.198.6053.0	25.198.1053.0		
50	58.05	50	22	25.198.6153.0	25.198.1153.0		
50	63.05	55	24	25.198.6253.0	25.198.1253.0		
pitch 5.08 mm							
50	13.25	5.08	4	25.199.5253.0	25.199.0253.0	25.199.9253.0	25.199.4253.0
50	18.33	10.16	6	25.199.5353.0	25.199.0353.0	25.199.9353.0	25.199.4353.0
50	23.41	15.24	8	25.199.5453.0	25.199.0453.0		
50	28.49	20.32	10	25.199.5553.0	25.199.0553.0		
50	33.57	25.40	12	25.199.5653.0	25.199.0653.0		
50	38.65	30.48	14	25.199.5753.0	25.199.0753.0		
50	43.73	35.56	16	25.199.5853.0	25.199.0853.0		
50	48.81	40.64	18	25.199.5953.0	25.199.0953.0		
50	53.89	45.72	20	25.199.6053.0	25.199.1053.0		
50	58.97	50.80	22	25.199.6153.0	25.199.1153.0		
50	64.05	55.88	24	25.199.6253.0	25.199.1253.0		

wiecon

with insulating plate, with locating cams

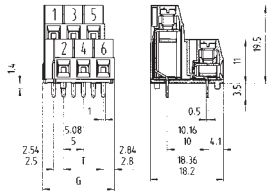

Drilling plan for version with locating cams

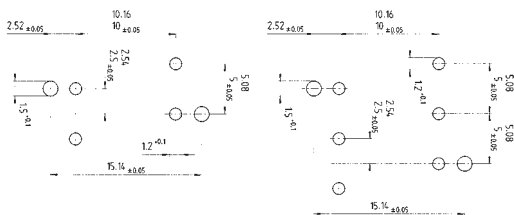

Materials

Insulating housing: PA 66/6 grey, UL 94-V0

Clamping part: nickel plated brass

Contact and solder pin: tin-plated bronze

Clamping screw: galvanised steel

Part No.	Part No.
unmarked with insulating plate without locating cams	marked with insulating plate without locating cams
on request	on request
on request	on request

PCB terminal, rising cage clamp system pitch 5.00/5.08 mm

wiecon PCB

Rated cross section:
2.5 mm²

Rated current:
16 A

Wire range:
0.14 – 4.0 mm² single core/
0.14 – 2.5 mm² finely stranded

250 V/4 kV/3 – Overvoltage category III
*690 V/4 kV/2 – Overvoltage category II
1000 V/4 kV/1 – Overvoltage category I

without insulating plate

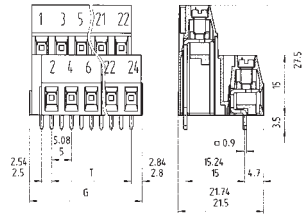

with insulating plate, without locating cams

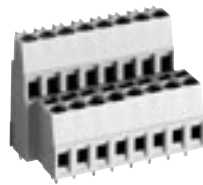
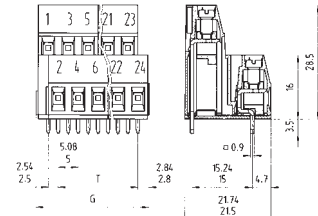

Solder pin 0.9 x 0.9 mm
Drill hole Ø 1.3 mm

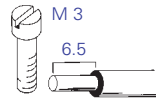

* max. 600 V for non-earthed systems or expected overvoltage
≤ 4 kV

Type 8191 E/8291 E

conductor horizontal to PCB

Rated voltages VDE 0110

UL Data

field/factory wiring

CSA Data

Approvals

No. 22 – 12 AWG

300 V 20/30 A

No. 22 – 12 AWG

300 V 25 A



Box Qty	G	T	Pole	Part No.	Part No.	Part No.	Part No.
				unmarked without insulating plate	marked without insulating plate	unmarked with insulating plate with locating cams	marked with insulating plate with locating cams
pitch 5.00 mm							
50	13.05	5	4	25.178.5253.0	25.178.0253.0	25.178.9253.0	25.178.4253.0
50	18.05	10	6	25.178.5353.0	25.178.0353.0	25.178.9353.0	25.178.4353.0
50	23.05	15	8	25.178.5453.0	25.178.0453.0		
50	28.05	20	10	25.178.5553.0	25.178.0553.0		
50	33.05	25	12	25.178.5653.0	25.178.0653.0		
50	38.05	30	14	25.178.5753.0	25.178.0753.0		
50	43.05	35	16	25.178.5853.0	25.178.0853.0		
50	48.05	40	18	25.178.5953.0	25.178.0953.0		
50	53.05	45	20	25.178.6053.0	25.178.1053.0		
50	58.05	50	22	25.178.6153.0	25.178.1153.0		
50	63.05	55	24	25.178.6253.0	25.178.1253.0		
pitch 5.08 mm							
50	13.25	5.08	4	25.179.5253.0	25.179.0253.0	25.179.9253.0	25.179.4253.0
50	18.33	10.16	6	25.179.5353.0	25.179.0353.0	25.179.9353.0	25.179.4353.0
50	23.41	15.24	8	25.179.5453.0	25.179.0453.0		
50	28.49	20.32	10	25.179.5553.0	25.179.0553.0		
50	33.57	25.40	12	25.179.5653.0	25.179.0653.0		
50	38.65	30.48	14	25.179.5753.0	25.179.0753.0		
50	43.73	35.56	16	25.179.5853.0	25.179.0853.0		
50	48.81	40.64	18	25.179.5953.0	25.179.0953.0		
50	53.89	45.72	20	25.179.6053.0	25.179.1053.0		
50	58.97	50.80	22	25.179.6153.0	25.179.1153.0		
50	64.05	55.88	24	25.179.6253.0	25.179.1253.0		

wiecon

with insulating plate, with locating cams

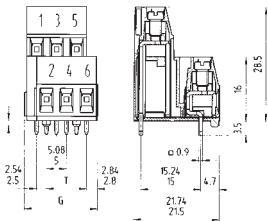

Drilling plan for version with locating cams

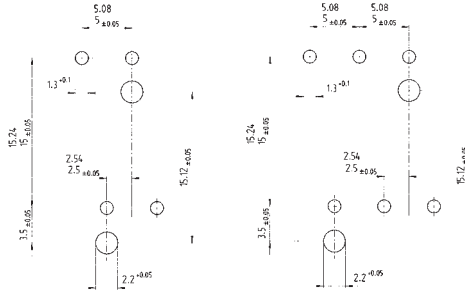

Materials

Insulating housing: PA 66/6 grey, UL 94-V2

Clamping part: nickel plated brass

Contact and solder pin: tin plated E-Cu

Clamping screw: galvanised steel

Part No.	Part No.
unmarked with insulating plate without locating cams	marked with insulating plate without locating cams
	on request
on request	on request

PCB terminal, rising cage clamp system pitch 5.00 mm

wiecon PCB

Rated cross section:
2.5 mm²

Rated current:
16 A

Wire range:
0.14 – 4.0 mm² single core/
0.14 – 2.5 mm² finely stranded

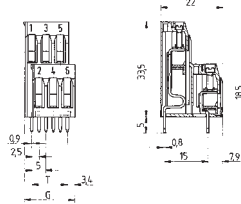

250 V/4 kV/3 – Overvoltage category III
*690 V/4 kV/2 – Overvoltage category II
1000 V/4 kV/1 – Overvoltage category I

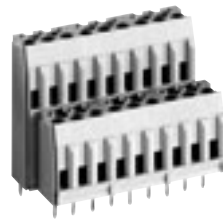

Solder pin 0.8 x 0.9 mm
Drill hole Ø 1.2 mm

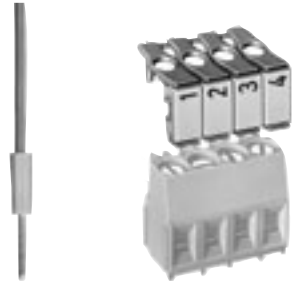
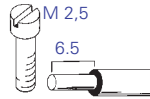

* max. 600 V for non-earthed systems or expected overvoltage
≤ 4 kV

Type 8190 E
conductor horizontal to PCB

No. 22 – 12 AWG 300 V 15 A
No. 22 – 14 AWG 300 V 10 A



Accessories
Type 8190 E

Rated voltages VDE 0110
UL Data
CSA Data
Approvals

pitch 5.00 mm	Box Qty	G	T	Pole	Part No.	Part No.	Pole	Part No.	Box Qty	
					unmarked	marked				
	50	13.36	5	4	25.131.3253.0	25.130.3253.0	1	Test plug nominal current = 2 A		
	50	18.36	10	6	25.131.3353.0	25.130.3353.0	2	25.543.0153.0	100	
	50	23.36	15	8	25.131.3453.0	25.130.3453.0		25.543.0253.0	100	
								Marker tag carrier for 12 pole, can be divided for smaller pole numbers		
	50	28.36	20	10	25.131.3553.0	25.130.3553.0		04.242.4653.0	50	
	50	33.36	25	12	25.131.3653.0	25.130.3653.0		Marker strips unmarked		
	50	38.36	30	14	25.131.3753.0	25.130.3753.0		04.242.5053.0	25	
	50	43.36	35	16	25.131.3853.0	25.130.3853.0		Marked 1 – 10, 11 – 20 etc. 991 – 999		
	50	48.36	40	18	25.131.3953.0	25.130.3953.0		04.842.5053.0	25	
	50	53.36	45	20	25.131.4053.0	25.130.4053.0		Marking branch labelled 1, 2, 3 ... 0		
	50	58.36	50	22	25.131.4153.0	25.130.4153.0		04.841.2150.0	25	
	50	63.36	55	24	25.131.4253.0	25.130.4253.0		Single tag, unmarked		
								04.242.0850.0	500	
								Marked		
								04.842.0850.0	500	
								Adhesive marking strips (1 sheet = 100 strips)		
								1 – 12	04.007.4089.0	1
								13 – 24	04.007.4189.0	1
								25 – 36	04.007.4289.0	1
								37 – 48	04.007.4389.0	1
								49 – 60	04.007.4489.0	1
								61 – 72	04.007.4589.0	1
								73 – 84	04.007.4689.0	1
								85 – 96	04.007.4789.0	1
								97 – 108	04.007.4889.0	1
Materials Insulating housing: PA 6/66, UL 94-V0 Clamping part: galvanised steel Contact and solder pin: tin plated E-Cu Clamping screw: galvanised steel										

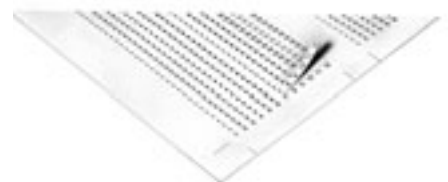

wiecon

PCB terminal, rising cage clamp system pitch 5.00/5.08 mm

wiecon PCB

Rated cross section:
2.5 mm²

Rated current:
16 A

Wire range:
0,14 – 4.0 mm² single core/
0.14 – 2.5 mm² finely stranded

250 V/4 kV/3 – Overvoltage category III
*690 V/4 kV/2 – Overvoltage category II
1000 V/4 kV/1 – Overvoltage category I

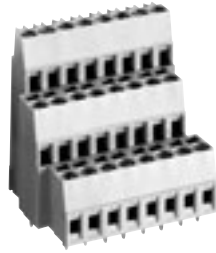

without insulating plate

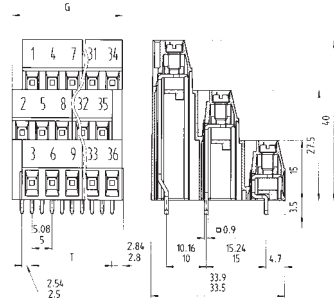

Solder pin 0.9 x 0.9 mm
Drill hole Ø 1.3 mm

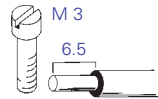

* max. 600 V for non-earthed systems or expected overvoltage
≤ 4 kV

Type 8191 D/8291 D

conductor horizontal to PCB

Rated voltages VDE 0110

UL Data

CSA Data

Approvals

field/factory wiring

No. 22 – 12 AWG

300 V 20/30 A

No. 22 – 12 AWG

300 V 25 A



Box Qty	G	T	Pole	Part No.	Part No.	Part No.	Part No.
				unmarked without insulating plate	marked without insulating plate	unmarked with insulating plate with locating cams	Marked with insulating plate with locating cams
pitch 5.00 mm							
50	12.8	5	6	25.180.5253.0	25.180.0253.0	25.180.9253.0	25.180.4253.0
50	17.8	10	9	25.180.5353.0	25.180.0353.0	25.180.9353.0	25.180.4353.0
50	22.8	15	12	25.180.5453.0	25.180.0453.0		
50	27.8	20	15	25.180.5553.0	25.180.0553.0		
50	32.8	25	18	25.180.5653.0	25.180.0653.0		
50	37.8	30	21	25.180.5753.0	25.180.0753.0		
50	42.8	35	24	25.180.5853.0	25.180.0853.0		
50	47.8	40	27	25.180.5953.0	25.180.0953.0		
20	52.8	45	30	25.180.6053.0	25.180.1053.0		
20	57.8	50	33	25.180.6153.0	25.180.1153.0		
20	62.8	55	36	25.180.6253.0	25.180.1253.0		
pitch 5.08 mm							
50	12.70	5.08	6	25.181.5253.0	25.181.0253.0	25.181.9253.0	25.181.4253.0
50	17.78	10.16	9	25.181.5353.0	25.181.0353.0	25.181.9353.0	25.181.4353.0
50	22.86	15.24	12	25.181.5453.0	25.181.0453.0		
50	27.94	20.32	15	25.181.5553.0	25.181.0553.0		
50	33.02	25.40	18	25.181.5653.0	25.181.0653.0		
50	38.10	30.48	21	25.181.5753.0	25.181.0753.0		
50	43.18	35.56	24	25.181.5853.0	25.181.0853.0		
50	48.26	40.64	27	25.181.5953.0	25.181.0953.0		
20	53.34	45.72	30	25.181.6053.0	25.181.1053.0		
20	58.42	50.80	33	25.181.6153.0	25.181.1153.0		
20	63.50	55.88	36	25.181.6253.0	25.181.1253.0		

wiecon

with insulating plate, **without** locating cams

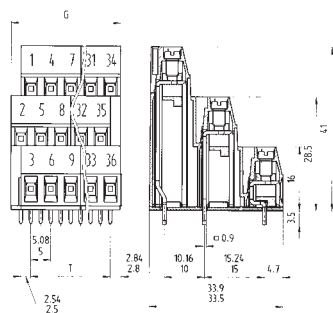

with insulating plate, **with** locating cams

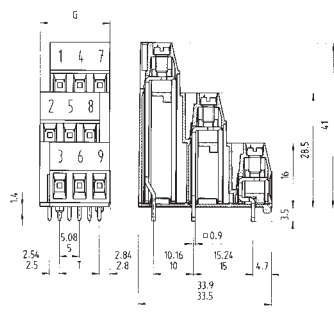

Drilling plan for version **with** locating cams

Materials

Insulating housing: PA 66/6 grey, UL 94-V0
 Clamping part: nickel plated brass
 Contact and solder pin: tin plated E-Cu
 Clamping screw: galvanised steel

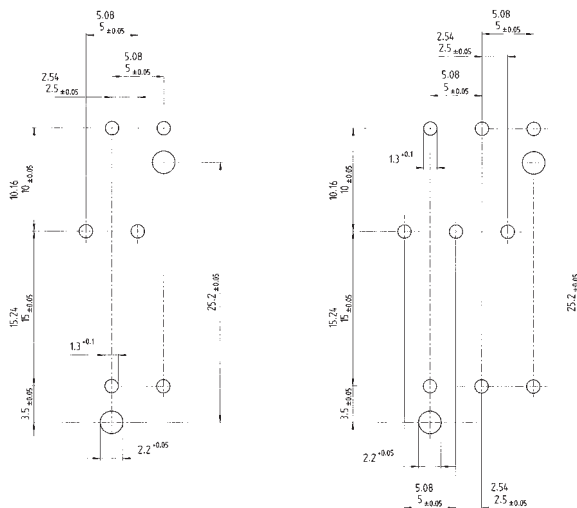

Part No.	Part No.
unmarked with insulating plate without locating cams	marked with insulating plate without locating cams
on request	on request
on request	on request

PCB terminal, rising cage clamp system pitch 5.00 mm

wiecon PCB

Rated cross section:
1.5 mm², earth 2.5 mm²

Rated current:
10 A

Wire range:
0.5 – 2.5 mm² single core 0.5 – 4.0 mm² (earth)
0.5 – 1.5 mm² finely stranded 0.5 – 2.5 mm² (earth)

250 V/4 kV/3 – Overvoltage category III
*690 V/4 kV/2 – Overvoltage category II
1000 V/4 kV/1 – Overvoltage category I

* max. 600 V for non-earthed systems or expected overvoltage
≤ 4 kV

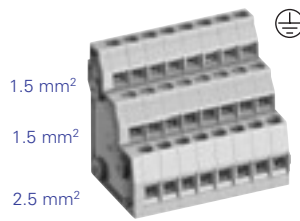
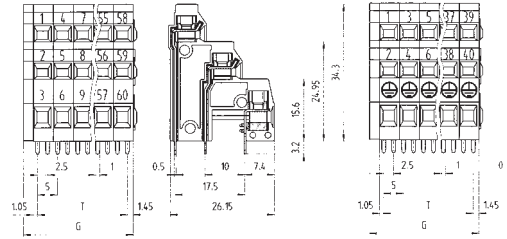

Solder pin 0.5 x 1.0 mm
Drill hole Ø 1.2 mm

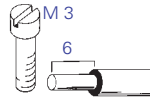

Materials **Type 8195 D/...** and
Type 8195 V/...
Insulating housing: PA 6/66, UL 94-V0
Clamping part: nickel plated brass
Contact and solder pin: tinned
Clamping screw: galvanised steel

Type 8195 D/...

conductor horizontal to PCB

Rated voltages VDE 0110

UL Data field/factory wiring
CSA Data
Approvals

No. 30 – 14 AWG 300 V 10 A No. 20 – 12 AWG for PE
No. 30 – 14 AWG 300 V 10 A No. 20 – 12 AWG for PE



Box Qty	G	T	Pole	Part No.	Part No.
pitch 5.00 mm				unmarked	marked
50	12.50	7.50	6	25.153.2253.0	25.153.0253.0
50	17.50	12.50	9	25.153.2353.0	25.153.0353.0
50	22.50	17.50	12	25.153.2453.0	25.153.0453.0
50	27.50	22.50	15	25.153.2553.0	25.153.0553.0
50	32.50	27.50	18	25.153.2653.0	25.153.0653.0
50	37.50	32.50	21	25.153.2753.0	25.153.0753.0
50	42.50	37.50	24	25.153.2853.0	25.153.0853.0
20	47.50	42.50	27	25.153.2953.0	25.153.0953.0
20	52.50	47.50	30	25.153.3053.0	25.153.1053.0
	33 to 60 pole on request				
Sensor terminals pitch 5.00 mm				Type 8195 D/... VB1	marked
			⊕ jumpered	unmarked	
50		2 PE + 4		25.153.6253.0	25.153.4253.0
50		3 PE + 6		25.153.6353.0	25.153.4353.0
50		4 PE + 8		25.153.6453.0	25.153.4453.0
50		5 PE + 10		25.153.6553.0	25.153.4553.0
50		6 PE + 12		25.153.6653.0	25.153.4653.0
50		7 PE + 14		25.153.6753.0	25.153.4753.0
50		8 PE + 16		25.153.6853.0	25.153.4853.0
50		9 PE + 18		25.153.6953.0	25.153.4953.0
20		10 PE + 20		25.153.7053.0	25.153.5053.0
	11 earth + 33 up to 20 earth + 60 on request				

wiecon

Rated cross section:
1.5 mm², earth 2.5 mm²

Rated current:
10 A

Wire range:
0.5 – 2.5 mm² single core 0.5 – 4.0 mm² (earth)
0.5 – 1.5 mm² finely stranded 0.5 – 2.5 mm² (earth)

250 V/4 kV/3 – Overvoltage category III
*690 V/4 kV/2 – Overvoltage category II
1000 V/4 kV/1 – Overvoltage category I

* max. 600 V for non-earthed systems or expected overvoltage
≤ 4 kV

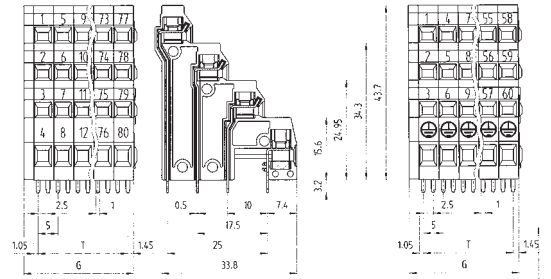
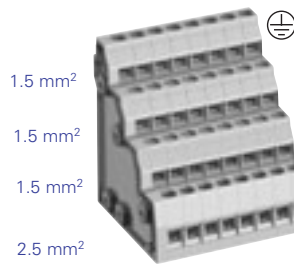

Solder pin 0.5 x 1.0 mm
Drill hole Ø 1.2 mm

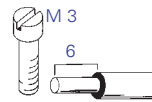

Type 8195 V/...

conductor horizontal to PCB

Rated voltages VDE 0110

UL Data

CSA Data

Approvals

field/factory wiring

No. 30 – 14 AWG

No. 30 – 14 AWG



300 V

300 V

10 A

10 A

No. 20 – 12 AWG for PE

No. 20 – 12 AWG for PE

Box Qty	G	T	Pole	Part No.	Part No.
pitch 5.00 mm				unmarked	marked
50	12.50	7.50	8	25.154.2253.0	25.154.0253.0
50	17.50	12.50	12	25.154.2353.0	25.154.0353.0
50	22.50	17.50	16	25.154.2453.0	25.154.0453.0
50	27.50	22.50	20	25.154.2553.0	25.154.0553.0
50	32.50	27.50	24	25.154.2653.0	25.154.0653.0
50	37.50	32.50	28	25.154.2753.0	25.154.0753.0
50	42.50	37.50	32	25.154.2853.0	25.154.0853.0
20	47.50	42.50	36	25.154.2953.0	25.154.0953.0
20	52.50	47.50	40	25.154.3053.0	25.154.1053.0
44 to 80 pole on request					
Sensor terminals				Type 8195 V/... VB1	
pitch 5.00 mm				unmarked	marked
				⊕ jumpered	
50		2 PE + 6		25.154.6253.0	25.154.4253.0
50		3 PE + 9		25.154.6353.0	25.154.4353.0
50		4 PE + 12		25.154.6453.0	25.154.4453.0
50		5 PE + 15		25.154.6553.0	25.154.4553.0
50		6 PE + 18		25.154.6653.0	25.154.4653.0
50		7 PE + 21		25.154.6753.0	25.154.4753.0
50		8 PE + 24		25.154.6853.0	25.154.4853.0
50		9 PE + 27		25.154.6953.0	25.154.4953.0
20		10 PE + 30		25.154.7053.0	25.154.5053.0
11 earth + 33 to 20 earth + 60 on request					

Drilling plan Type 8195 D/... and Type 8195 V/...

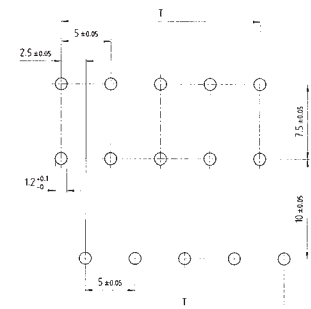

PCB terminal, rising cage clamp system pitch 7.50 mm

wiecon PCB

Rated cross section:
4.0 mm²

Rated current:
30 A

Wire range:
0.14 – 6.0 mm² single core/
0.14 – 4.0 mm² finely stranded

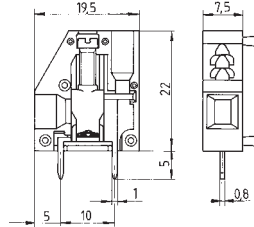

Materials
Insulating housing: PA 66/6 grey,
UL 94-V0
Clamping part: galvanised steel
Contact and solder pin:
tin plated E-Cu
Clamping screw: galvanised steel

Rated voltages
pitch 7.50 mm
500 V/6 kV/3 – Overvoltage category III
1000 V/6 kV/2 – Overvoltage category II
1000 V/6 kV/1 – Overvoltage category I

pitch 10.00 mm, UL 600 V, CSA 600 V
690 V/8 kV/3 – Overvoltage category III
1000 V/8 kV/2 – Overvoltage category II
1000 V/8 kV/1 – Overvoltage category I

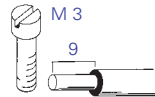
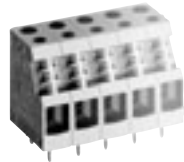

Solder pin 0.8 x 1.0 mm
Drill hole Ø 1.3 mm

Rated voltages VDE 0110
UL Data field/factory wiring
CSA Data
Approvals

Type 8375

conductor horizontal to PCB
No. 22/30 – 10 AWG 300 V 30/35 A
No. 22 – 10 AWG 300 V 30 A



	Type	Part No.	Box Qty	
pitch 7.50 mm				
Individual poles connected in series 1 pole	8375	25.700.0153.0	100	
Accessories				
pitch 10.00 mm				
Pitch intermediate plate (increases pitch from 7.50 to 10.00 mm)		07.300.2753.0	50	
Test plug red	ST 2/2,3	Z5.553.2921.0	10	
Marking strips unmarked	9705 A/7,5/10	04.242.7553.0	25	
1 – 10, 11 – 20 etc. 991 – 999 ¹⁾ marked	9705 A/7,5/10 B	04.842.7553.0	25	
Marking branch labelled 1, 2, 3 ... 0	9704 A/1-0 B	04.841.2150.0	25	
Single tag unmarked	9705 A	04.242.0850.0	500	
¹⁾ marked	9705 AB	04.842.0850.0	500	
¹⁾ Labelling on request				

wiecon

Rated cross section: 10.0 mm²

Rated current: 59 A

(based on ambient temperature 20 °C rated cross section and max. number of poles)

Wire range:

0.50 – 10.0 mm² single core and finely stranded

- 400 V/6 kV/3 – Overvoltage category III
- 690 V/6 kV/2 – Overvoltage category II
- 1000 V/6 kV/1 – Overvoltage category I

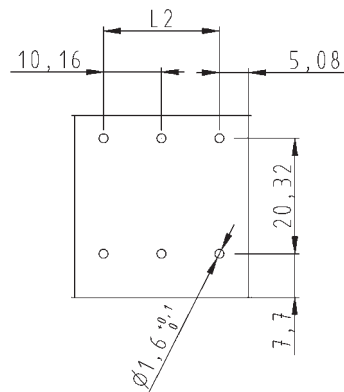
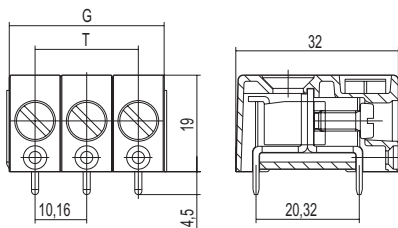

Solder pin 1.2 x 1.4 mm
Drill hole Ø 1.6 mm

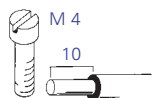

Type 7573 L2.../W

Rated voltages VDE 0110

UL Data

field-/factory wiring

No. 22 – 8 AWG

300 V 10 A

CSA Data

No. 22 – 8 AWG

300 V 10 A

Approvals



pitch 10.16 mm		Box Qty	G	T	Pole	Part No.
pitch 10.16 mm						unmarked
	50	10.16			1	27.002.6153.0
	50	30.48	20.32		3	27.002.6353.0
	50	40.64	30.48		4	27.002.6453.0

**PCB terminal, rising cage clamp system
pitch 10.16 mm**

wiecon PCB

Rated cross section:
10 mm²

Rated current:
57 A

(based on ambient 20°C, rated cross section and max. number of poles)

Wire range:
0.50 – 16.0 mm² single core/
0.50 – 10.0 mm² finely stranded

Rated voltages

4 solder pins
250 V/4 kV/3 – Overvoltage category III
400 V/4 kV/2 – Overvoltage category III
630 V/4 kV/2 – Overvoltage category II

2 solder pins
630 V/8 kV/3 – Overvoltage category III
800 V/8 kV/2 – Overvoltage category III
1000 V/8 kV/2 – Overvoltage category II

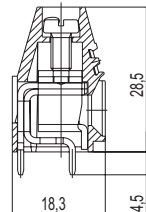
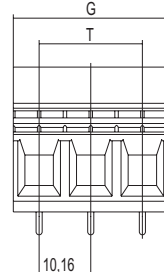
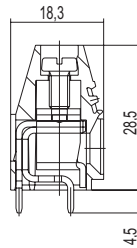
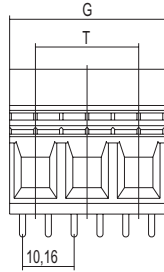

Solder pin 1.2 x 1.2 mm
Drill hole Ø 1.6 mm

4 solder pins

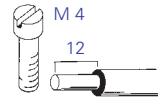

Solder pin 1.2 x 1.2 mm
Drill hole Ø 1.6 mm

2 solder pins

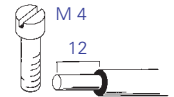

Rated voltages VDE 0110

UL Data field/factory wiring
CSA Data
Approvals

Type 7572 L4

No. 22 – 8 AWG
No. 22 – 8 AWG



300/150 V 10/40 A
300 V 10 A

Type 7572 L2

No. 22 – 8 AWG
No. 22 – 8 AWG



300/150 V 10/40 A
300 V 10 A

pitch 10.16 mm	Box Qty	G	T	Pole	Part No.	Part No.
					unmarked	unmarked
	50	20.32	10.16	2	27.002.0253.0	27.002.2253.0
	50	30.48	20.32	3	27.002.0353.0	27.002.2353.0

wiecon

Rated cross section:
10 mm²

Rated current:
57 A

(based on ambient temperature 20 °C rated cross section and max. number of poles)

Wire range:
0.50 – 16.0 mm² single core/
0.50 – 10.0 mm² finely stranded

Rated voltages
1000 V/8 kV/3 – Overvoltage category III

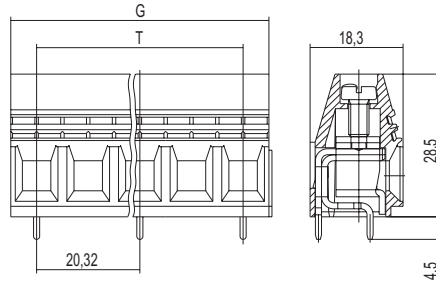

Solder pin 1.2 x 1.2 mm
Drill hole Ø 1.6 mm

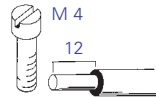

Type 7572 L2

Rated voltages VDE 0110

No. 22 – 6 AWG

600 V

60 A



Approvals

	Box Qty	G	T	Pole	Part No.	
pitch 20.32 mm					unmarked	
	50	30.48	20.32	2	27.002.4253.0	
	50	50.64	40.48	3	27.002.4353.0	

PCB terminal, rising cage clamp system pitch 5.08 mm

wiecon PCB

Rated cross section:
4.0 mm² single core/
2.5 mm² finely stranded

Rated current Type 8276: 26 A
Rated current Type 8276 TKS: 15 A

Wire range:
0.14 – 4.0 mm² single core/
0.14 – 2.5 mm² finely stranded

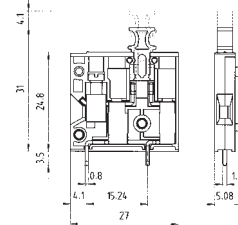
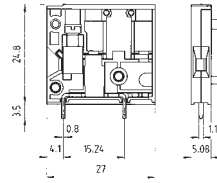

250 V/4 kV/3 – Overvoltage category III
400 V/4 kV/2 – Overvoltage category II
1000 V/4 kV/1 – Overvoltage category I

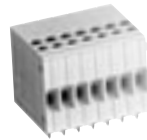

Solder pin 0.8 x 1.1 mm
Drill hole Ø 1.4 mm

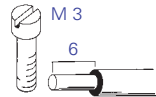

Solder pin 0.8 x 1.1 mm
Drill hole Ø 1.4 mm

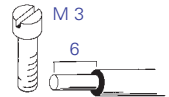

Rated voltages VDE 0110
UL Data
CSA Data
Approvals

field/factory wiring

Type 8276

modular terminal
No. 30 – 14 AWG
No. 30 – 14 AWG



300 V 15/23 A
300 V 20 A

Type 8276 TKS

disconnect terminal
No. 30 – 14 AWG
No. 30 – 14 AWG



300 V 15 A
300 V 15 A

	Type	Part No.	Box Qty	Type	Part No.	Box Qty
pitch 5.08 mm						
Individual poles connected in series 1 pole	8276	25.720.1353.0	100	8276 TKS	25.720.1453.0	100
Pole numbers latched together on request						
Accessories						
Adhesive marking strips						
	1 – 12	04.007.4089.0	1	1 – 12	04.007.4089.0	1
	13 – 24	04.007.4189.0	1	13 – 24	04.007.4189.0	1
	25 – 36	04.007.4289.0	1	25 – 36	04.007.4289.0	1
	37 – 48	04.007.4389.0	1	37 – 48	04.007.4389.0	1
	49 – 60	04.007.4489.0	1	49 – 60	04.007.4489.0	1
	61 – 72	04.007.4589.0	1	61 – 72	04.007.4589.0	1
	73 – 84	04.007.4689.0	1	73 – 84	04.007.4689.0	1
	85 – 96	04.007.4789.0	1	85 – 96	04.007.4789.0	1
	97 – 108	04.007.4889.0	1	97 – 108	04.007.4889.0	1
Test plug red	ST 2/2,3	Z5.553.2921.0	10	ST 2/2,3	Z5.553.2921.0	10
	Materials Type 8276 Insulating housing: PA 66/6 grey, UL 94-V0 Clamping part: nickel plated brass Contact and solder pin: tin plated E-Cu Clamping screw: galvanised steel			Materials Type 8276 TKS Insulating housing: PA 66/6 grey, UL 94-V0 Disconnect component: PA 66/6 orange, UL 94-V0 Clamping part: nickel plated brass Contact spring and solder pin: special copper alloy, tin plated Clamping screw: galvanised steel Isolating blade: tin plated E-Cu		

PCB terminal, rising cage clamp system pitch 5.08 mm



Rated cross section:
2.5 mm²

Rated current:
6.3 A**

Wire range:
0.14 – 4.0 mm² single core/
0.14 – 2.5 mm² finely stranded

250 V/4 kV/3 – Overvoltage category III
*690 V/4 kV/2 – Overvoltage category II
1000 V/4 kV/1 – Overvoltage category I

* max. 600 V for non-earthed systems or expected overvoltage
≤ 4 kV

** voltage and current are determined by the fuse link used
6.3 A up to a power loss of 1.6 W

IEC 60 127-2/ DIN VDE 0820 T2 should be
observed when selecting and using fuse link
DIN VDE 0820 T2

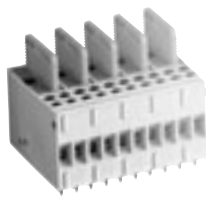
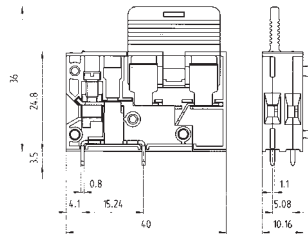

Solder pin 0.8 x 1.1 mm
and 0.5 x 1.1 mm
Drill hole Ø 1.4 mm

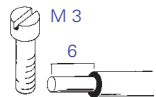

Rated voltages VDE 0110
UL Data
CSA Data
Approvals

Type 8276 Si-D

modular fuse terminal (for Si 5 x 20)
No. 30 – 14 AWG 300 V 6.3 A
No. 30 – 14 AWG 300 V 6.3 A



	Type	Part No.	Box Qty	
pitch 5.08 mm				
Individual poles connected in series 1 pole	8276 Si-D	25.720.1653.0	100	
Pole numbers latched together on request				
Accessories				
Adhesive marking strips				
	1 – 12	04.007.4089.0	1	
	13 – 24	04.007.4189.0	1	
	25 – 36	04.007.4289.0	1	
	37 – 48	04.007.4389.0	1	
	49 – 60	04.007.4489.0	1	
	61 – 72	04.007.4589.0	1	
	73 – 84	04.007.4689.0	1	
	85 – 96	04.007.4789.0	1	
	97 – 108	04.007.4889.0	1	
Unmarked for customised labelling		04.007.3989.0	1	
Test plug red	ST 2/2,3	Z5.553.2921.0	10	
	Materials Type 8276 Si-D Insulating housing: PA 66/6 grey, UL 94-V0 Fuse holder: PA 66/6 orange, UL 94-V0 Clamping part: nickel plated brass Contact and solder pin: special copper alloy, tin plated Contact spring and solder pin: special copper alloy, tin plated Clamping screw: galvanised steel			

Type 8105 B, *RAST 5* Technology,
PCB plug-in terminal, tab connector

wiecon PCB

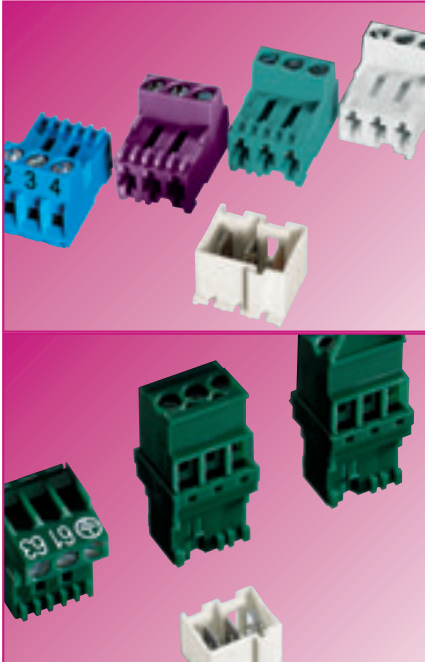

Technical progress has probably seen the fastest advances in recent times in areas of electronics. Devices have become more sophisticated, requiring large numbers of components for functionality. To make them work together, printed circuit boards are used. For fitting these, Wieland Electric offer plug-in printed circuit board screw terminals with a *RAST 5* system which, combined with the corresponding tab connectors can be connected indirectly.

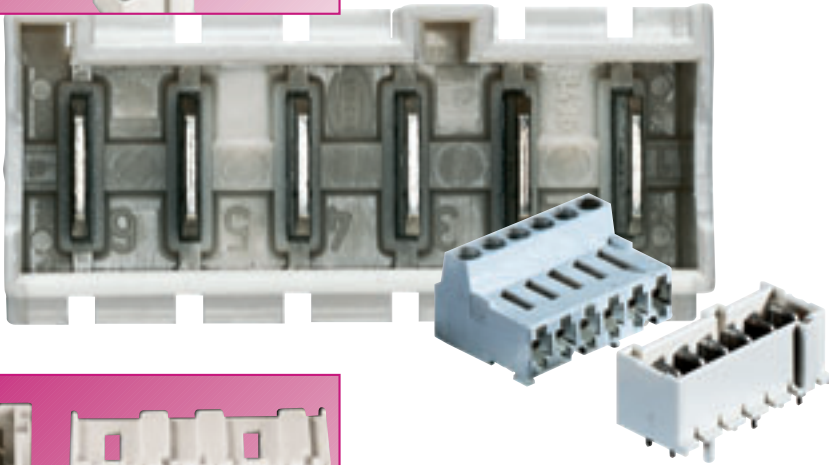

Fixed coding (without coding strip of type 8105) is designed in accordance with the *RAST 5* standard and corresponds to all known requirements that have been drawn up for 'white goods'. The same also applies to the standard variants that, apart from being connected horizontally, can also be connected vertically left and right or as tab connectors in a straight line.

They are all based on a rated current of 10A. The range extends from 2 – 7 poles. The conductor connection can be carried out with finely stranded 0.14 mm^2 – 2.5 mm^2 , with or without ferrules, and as a single-core from 0.14 mm^2 – 4 mm^2 .



wiecon

		Page 382	Page 382	Page 383	Page 383	Page 383
Type		8105 B/...C...	8105 B/...C...VR	8105 B/...C...VL	8105 F/...GC...	8105 F/WC...
pitch	mm	5.00	5.00	5.00	5.00	5.00
cross section	mm²	2.5	2.5	2.5	-	-
pole		2-7	2-7	2-7	2-7	2-7

RAST 5 coding diagram

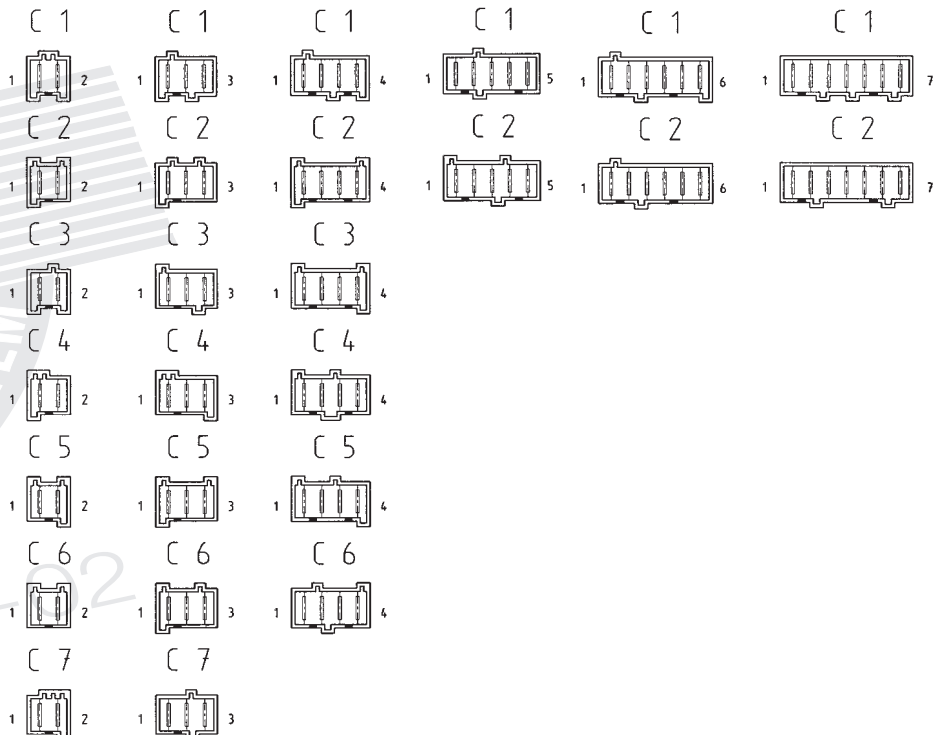
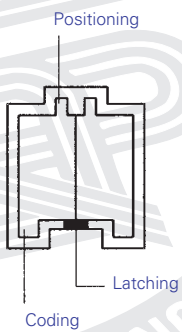

RAST 5 pluggable PCB terminal, pitch 5.00 mm

wiecon PCB

Rated cross section:
2.5 mm²

Rated current: 10 A

Wire range:
0.20 – 4.0 mm² single core/
0.14 – 2.5 mm² finely stranded

250 V/4 kV/3 – overvoltage category III
400 V/4 kV/2 – overvoltage category II
1000 V/4 kV/1 – overvoltage category I

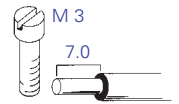
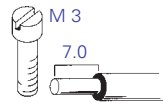
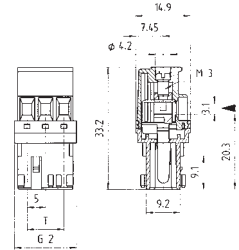
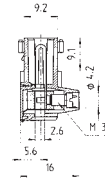
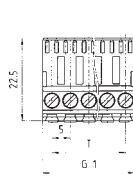

Type 8105 B/... C... OB

Type 8105 B/... C... VR OB

Rated voltages VDE 0110

UL Data

CSA Data

Approvals

No. 26 – 12 AWG

300 V

10 A

No. 26 – 12 AWG

300 V

10 A

No. 26 – 12 AWG

300 V

10 A

No. 26 – 12 AWG

300 V

10 A



Box Qty	Poles	Coding	Part No.	Part No.
pluggable PCB terminal/header				
unmarked				
unmarked				
100	2	C0	15.000.0253.0	15.020.0253.0
100		C1	15.001.0253.0	15.021.0253.0
100		C2	15.002.0253.0	15.022.0253.0
100		C3	15.003.0253.0	15.023.0253.0
100		C4	15.004.0253.0	15.024.0253.0
100		C5	15.005.0253.0	15.025.0253.0
100		C6	15.006.0253.0	15.026.0253.0
100		C7	15.007.0253.0	15.027.0253.0
100	3	C0	15.000.0353.0	15.020.0353.0
100		C1	15.001.0353.0	15.021.0353.0
100		C2	15.002.0353.0	15.022.0353.0
100		C3	15.003.0353.0	15.023.0353.0
100		C4	15.004.0353.0	15.024.0353.0
100		C5	15.005.0353.0	15.025.0353.0
100		C6	15.006.0353.0	15.026.0353.0
100		C7	15.007.0353.0	15.027.0353.0
50	4	C0	15.000.0453.0	15.020.0453.0
50		C1	15.001.0453.0	15.021.0453.0
50		C2	15.002.0453.0	15.022.0453.0
50		C3	15.003.0453.0	15.023.0453.0
50		C4	15.004.0453.0	15.024.0453.0
50		C5	15.005.0453.0	15.025.0453.0
50		C6	15.006.0453.0	15.026.0453.0
50	5	C0	15.000.0553.0	15.020.0553.0
50		C1	15.001.0553.0	15.021.0553.0
50		C2	15.002.0553.0	15.022.0553.0
50	6	C0	15.000.0653.0	15.020.0653.0
50		C1	15.001.0653.0	15.021.0653.0
50		C2	15.002.0653.0	15.022.0653.0
50	7	C0	15.000.0753.0	15.020.0753.0
50		C1	15.001.0753.0	15.021.0753.0
50		C2	15.002.0753.0	15.022.0753.0

wiecon

RAST 5 PCB header

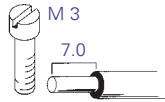
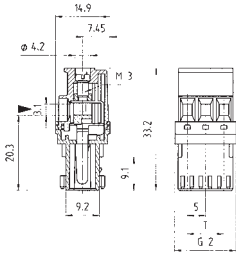

Type 8105 B/... C... VL OB

No. 26 – 12 AWG 300 V 10 A
 No. 26 – 12 AWG 300 V 10 A



Drilling hole, component size

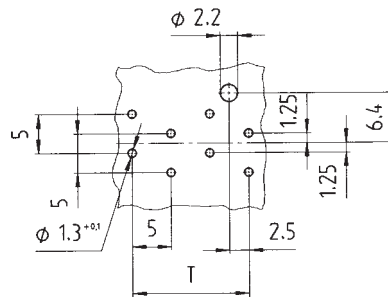

Positioning pins are omitted from design
 8105 F/... WC ...OB

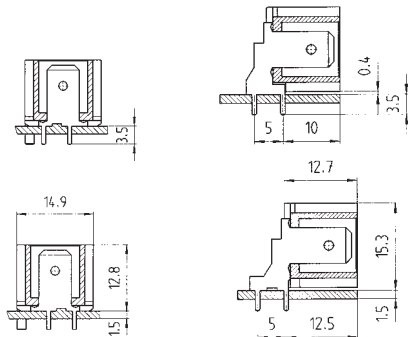

**Type 8105 F/... GC ... OB /
 8105 F/... WC... OB**

No. 26 – 12 AWG 300 V 10 A
 No. 26 – 12 AWG 300 V 10 A



Part No.	Box Qty	G1	G2	G3	T	Part No.	Part No.
unmarked					RAST 5	unmarked	unmarked
15.010.0253.0	10	11.8			5	15.301.0258.9	15.311.0258.9
15.011.0253.0	10	11.8	12		5	15.302.0258.9	15.312.0258.9
15.012.0253.0	10	11.8	12		5	15.303.0258.9	15.313.0258.9
15.013.0253.0	10	11.8	12		5	15.304.0258.9	15.314.0258.9
15.014.0253.0	10	11.8	12		5	15.305.0258.9	15.315.0258.9
15.015.0253.0	10	11.8	12		5	15.306.0258.9	15.316.0258.9
15.016.0253.0	10	11.8	12		5	15.307.0258.9	15.317.0258.9
15.017.0253.0	10	11.8	12		5		
15.010.0353.0	15	16.8			10	15.301.0358.9	15.311.0358.9
15.011.0353.0	15	16.8	17		10	15.302.0358.9	15.312.0358.9
15.012.0353.0	15	16.8	17		10	15.303.0358.9	15.313.0358.9
15.013.0353.0	15	16.8	17		10	15.304.0358.9	15.314.0358.9
15.014.0353.0	15	16.8	17		10	15.305.0358.9	15.315.0358.9
15.015.0353.0	15	16.8	17		10	15.306.0358.9	15.316.0358.9
15.016.0353.0	15	16.8	17		10	15.307.0358.9	15.317.0358.9
15.017.0353.0	15	16.8	17		10		
15.010.0453.0	20	21.8			15	15.301.0458.9	15.311.0458.9
15.011.0453.0	20	21.8	22		15	15.302.0458.9	15.312.0458.9
15.012.0453.0	20	21.8	22		15	15.303.0458.9	15.313.0458.9
15.013.0453.0	20	21.8	22		15	15.304.0458.9	15.314.0458.9
15.014.0453.0	20	21.8	22		15	15.305.0458.9	15.315.0458.9
15.015.0453.0	20	21.8	22		15	15.306.0458.9	15.316.0458.9
15.016.0453.0	20	21.8	22		15		
15.010.0553.0	25	26.8			20	15.301.0558.9	15.311.0558.9
15.011.0553.0	25	26.8	27		20	15.302.0558.9	15.312.0558.9
15.012.0553.0	25	26.8	27		20		
15.010.0653.0	30	31.8			25	15.301.0658.9	15.311.0658.9
15.011.0653.0	30	31.8	32		25	15.302.0658.9	15.312.0658.9
15.012.0653.0	30	31.8	32		25		
15.010.0753.0	35	36.8			30	15.301.0758.9	15.311.0758.9
15.011.0753.0	35	36.8	37		30	15.302.0758.9	15.312.0758.9
15.012.0753.0	35	36.8	37		30		

RAST 5 technology

Equipotential distribution board for PCB, pitch 5.00 mm

wiecon PCB

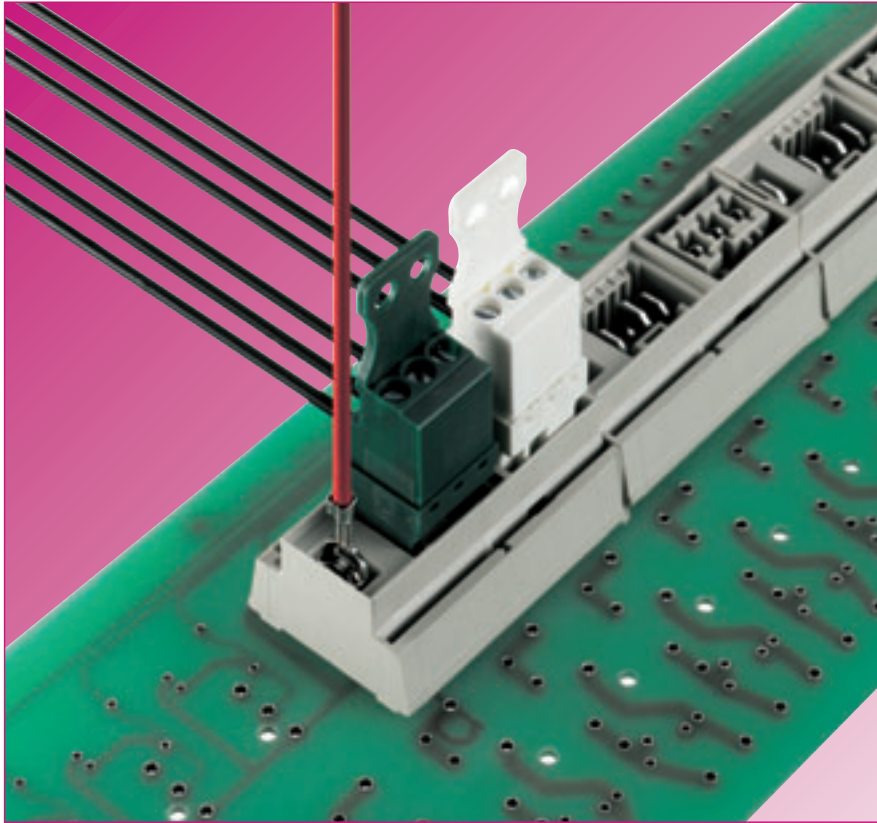

Customer specific connection modules with RAST 5 technology

Main area of application:

RAST 5 technology: "White" and "Brown" goods

Main benefits of RAST 5:

- fixed integrated coding
- incorrect connections are not possible
- variety of colours available
(benefit: immediate assignment of socket and plug component)
- optimum for on-site installations

Wieland offers customer specific modifications e.g. single part RAST 5 connection modules

- integrated jumper rail
(e.g. earth conductor)
- socket and plug components in the connection module for potential distribution
(guideline: socket must always be the conducting component)
- any combination of plugs/sockets with variable number of poles
- variety of colours

wiecon

Rated cross section:
2.5 mm²

Rated current: 10 A

Wire range:
0.14 – 4.0 mm² single core/
0.14 – 2.5 mm² finely stranded

250 V/2.5 kV/3 – overvoltage category III
*690 V/2.5 kV/2 – overvoltage category II
1000 V/2.5 kV/1 – overvoltage category I

No. of poles: 2 – 7

* max. 600 V for non-earthed systems or expected overvoltage
≤ 4 kV

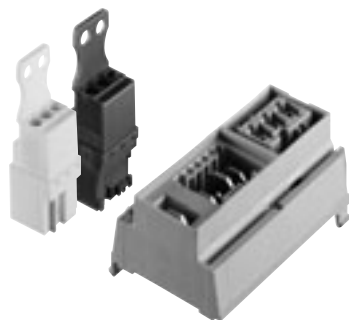

Type 8105 BF/3/4

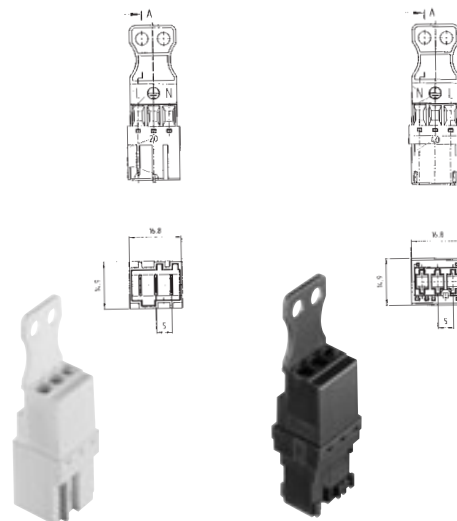

plug component

socket component

Rated voltages VDE 0110
UL Data
CSA Data – pending
Approvals



pitch 5.00 mm	Type	Part No.	Box Qty	Type	Part No.	Box Qty
		99.243.3564.7	100	plug component with strain relief, white	99.239.3564.7	100
				socket component with strain relief, green	99.259.3564.7	100

Termination modules TM 6 / TM 12

wiecon TER



External wiring



Internal wiring

Termination modules in *RAST 5* technology (IP 54) for series installation

The time consuming task of feeding through various external cables into the control cabinet has come to an end. With its termination module, **Wieland** has developed a cost effective and simple wiring method for modular installation.

Modular *RAST 5* control cabinet glanding with secure connection.

The principal aim is to optimise production of multiple installations with this wiring system by using cable assemblies with coded plugs.

A 100% testing of the cables and coding enables production that saves both time and costs.

Benefits compared to the conventional screw gland:

- installation time reduced by up to 80 % compared to conventional methods
- time and cost savings due to pre-assembled cables
- glanding with IP 54 protection
- error rate is zero as it is impossible to make a wrong connection
- specialist personnel are not required to connect the external wiring

wiecon



The external *RAST 5* connectors are available as 3 to 5 pole and prevent any errors during connection due to the secure coding system. The fixing of labels ensures that each plug can be rapidly assigned to the respective socket for modules with higher pole numbers.

The external connecting cables with special plugs which provide insulation with protection type IP 54, are supplied as prefabricated with the cable types required by the customer.

There is also the possibility of attaching further components to the other end of the cable such as outlet boxes e.g. temperature transducers.

The internal wiring is carried out either using cables with insulated

- *RAST 5* push-on blade
- *RAST 5* screwed bush
- *RAST 5* crimp connector

System configuration

- There are 2 basic modules
- Module with 6 slots = TM 6
 - Module with 12 slots = TM 12



TM 6

The TM 6 module has the following variants

- 6 slots 3 pole = Type **TM 6-3**
- 6 slots 4 pole = Type **TM 6-4**
- 6 slots 5 pole = Type **TM 6-5**

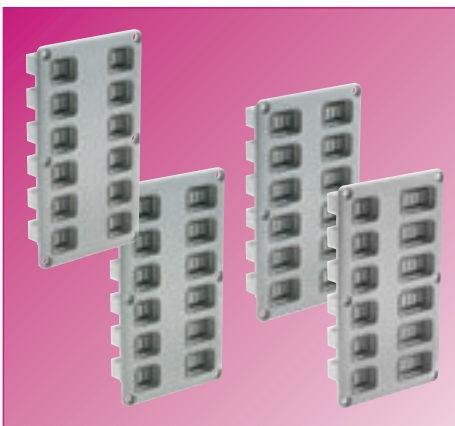

TM 12

The TM 12 module has the following variants 12 slots in two rows of 6

- 3 pole / 3 pole = Type **TM 12-33**
- 3 pole / 4 pole = Type **TM 12-34**
- 4 pole / 4 pole = Type **TM 12-44**
- 3 pole / 5 pole = Type **TM 12-35**

All these types are coded to ensure a reliable connection i.e. there are no identical slots within a module and there are 2 variants of each type.

Cable types of external cables

The following standard cable types are available:

- Ölflex Quattro 150 in the pole numbers 3/4/5 pole
- Ölflex quattro 150 CY (shield version) in the pole numbers 3/4/5 pole

The quantity of possible combinations of modules, codes and cables makes it possible to implement a variety of customer-specific wiring solutions. Special module variants and cables are also possible.

To test the variety of possible variations, it is possible to order the function set TM 6-5 with cables.

Technical data of the TM modules and external cables

Wire range: 1.5 mm² (Standard)

Rated voltage: 250 V/4 kV/3 – overvoltage category III

Rated current intensity: 10 A

Approvals in preparation: UL, CSA and VDE

Application of the TM Module 6/12 in the control cabinet

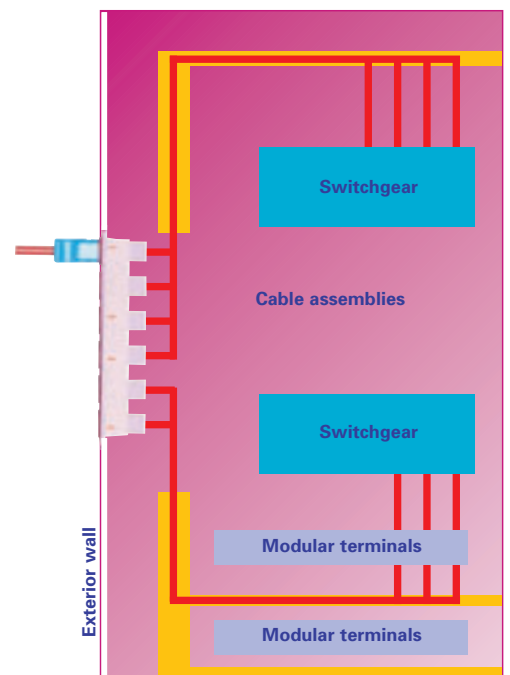

Function set TM 6

wiecon TER

Function set, consisting of
 1 x TM 6-5 including cable set 6 x 10 m Öflex
 Quattro cable 5 x 1.5 mm²
 with a 5 pole plug in the blade version



6 slots 3 pole =
 Type **TM 6-3**



6 slots 4 pole =
 Type **TM 6-4**

Type TM 6-5 F

Type TM 6-3

Type TM 6-4

Type	Part No.	Box Qty	Type	Part No.	Box Qty	Type	Part No.	Box Qty
TM 6-5 F	99.483.0000.0	on request	TM 6-3		auf Anfrage	TM 6-4		on request
			coding on request			coding on request		

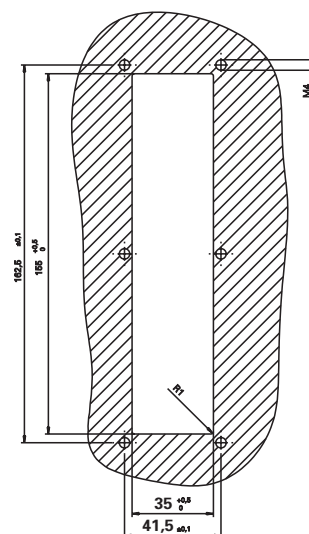

Drill hole
 D = 3.8
 for self tapping screw
 05.084.0212.0

Overall dimensions, steel cutout and drill hole configuration are identical for all TM6 variants

wiecon



6 slots 5 pole =
Type **TM 6-5**



TM 6 Cover

suitable for all pole combinations



Sealing plug

Type TM 6-5

Type	Part No.	Box Qty	Type	Part No.	Box Qty	Type	Part No.	Box Qty
TM 6-5		on request	TM 6-X	15.800.9956.0		3 pole	05.562.5957.1	
coding on request						4 pole	05.562.6557.1	
						5 pole	05.562.8257.1	

Function set TM 12



12 slots in two rows of 6
3 pole/3 pole =
Type **TM 12-33**



12 slots in two rows of 6
3 pole/4 pole =
Type **TM 12-34**



12 slots in two rows of 6
4 pole/4 pole =
Type **TM 12-44**

Type TM 12-33

Type TM 12-34

Type TM 12-44

Type	Part No.	Box Qty	Type	Part No.	Box Qty	Type	Part No.	Box Qty
TM 12-33		on request	TM 12-34		on request	TM 12-44		on request
coding on request			coding on request			coding on request		

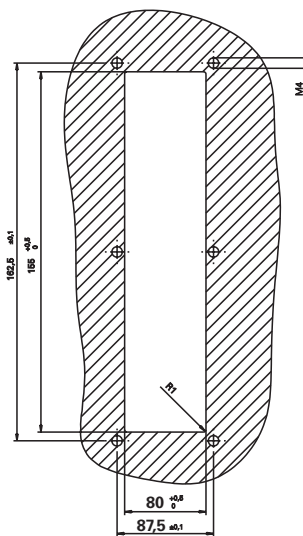

Drill hole
D = 3.8
for self tapping screw
05.084.0212.0

Overall dimensions, steel cutout and drill hole configuration are identical for all 6 variants

wiecon



12 slots in two rows of 6
3 pole/5 pole =
Type **TM 12-35**



TM 12 cover

suitable for all pole combinations TM 12-XX



Sealing plug

Type TM 12-55

Type	Part No.	Box Qty	Type	Part No.	Box Qty	Type	Part No.	Box Qty
TM 12-35		on request	TM 12-XX	15.800.8856.0		3 pole	05.562.5957.1	
coding on request						4 pole	05.562.6557.1	
						5 pole	05.562.8257.1	

Node connector (insulation displacement technology) pitch 5.00/5.08 mm

wiecon ASI

Rated cross section:
0.75 mm²

Rated current:
3 A

Wire range:
0.50 – 0.75 mm² finely stranded

250 V/4 kV/3 – overvoltage category III
400 V/4 kV/2 – overvoltage category II
1000 V/4 kV/1 – overvoltage category I

Current range:
3 mA to 3 A

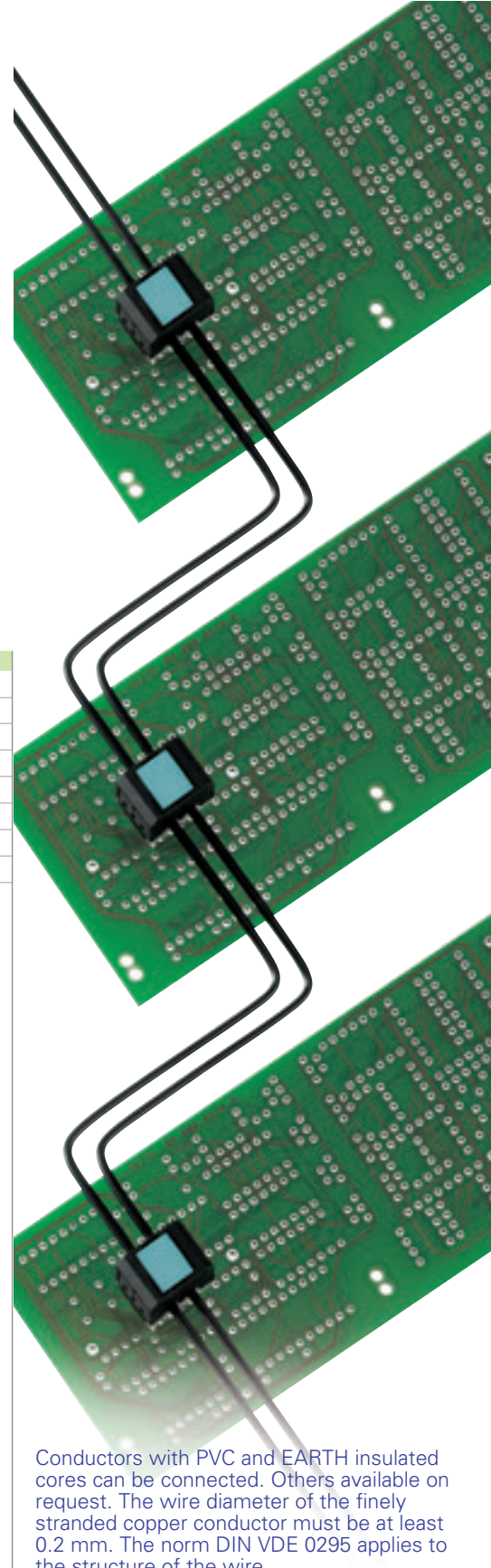
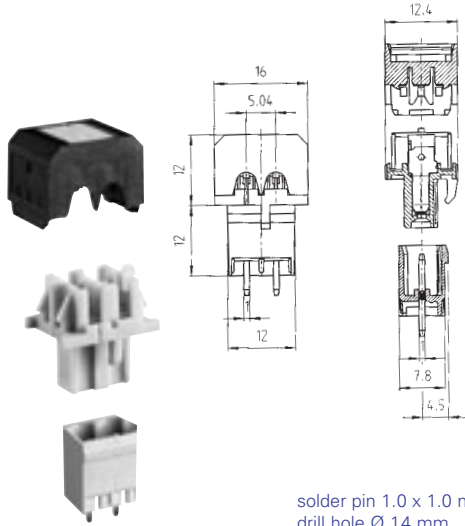

Type 8113 BSK/2

Rated voltages VDE 0110

UL Data

CSA Data

Approvals

field-/factory wiring

No. 20 – 18 AWG

No. 20 – 18 AWG



300 V

300 V

3 A

3 A

	Type	Part No.	Box Qty
pitch 5.00/5.08 mm			
ASI node connector	2 pole		
Cap	black	25.399.9853.0	100
Cap	yellow	25.399.9853.8	100
Cap	red	25.399.9853.5	100
(colour of socket base: grey)			
Marker tag	green	04.240.0953.0	100

Conductors with PVC and EARTH insulated cores can be connected. Others available on request. The wire diameter of the finely stranded copper conductor must be at least 0.2 mm. The norm DIN VDE 0295 applies to the structure of the wire.

PCB header
pitch 5.00/5.08 mm



Rated current:
12 A

250 V/4 kV/3 – overvoltage category III
400 V/4 kV/2 – overvoltage category II
1000 V/4 kV/1 – overvoltage category I

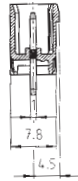

solder pin 1.0 x 1.0 mm
drill hole Ø 1.4 mm

Type 8113 S/... G, 8213 S/... G

Connection vertical to PCB

No. 22 – 12 AWG 250 V 15 A
No. 22 – 12 AWG 300 V 12 A



Rated voltages VDE 0110
UL Data
CSA Data
Approvals

Box Qty	G	T	Pole	Part No.
pitch 5.00 mm				
100	11.40	5	2	unmarked 25.330.3253.0
pitch 5.08 mm				
100	11.56	5.08	2	unmarked 25.350.3253.0

ASI branch connector with insulation piercing technology

The ASI connector has been developed for both ASI bus systems and LON and EIBA systems. In these systems, auxiliary voltage and information are transmitted simultaneously via the two cores of the bus cable.

The ASI node connector, a plug-in PCB terminal with insulation displacement technology, ensures that the required signal to the actuator or sensor is picked up.

The wiring of the ASI node connector is both simple and effective:

The two cables are laid in the open terminal compartment of the connector and the cover is then pressed into position with a pair of pliers that closes vertically – the connection is then made. The connection to the PCB is established by plugging onto a 2 pole header.

Note: The considerably more cost-effective standard wire is used here instead of the ASI special cable.

Materials
Insulating component: PA 66/6
CI-Index: ≥ 600
Fire protection class: UL 94-V-2
Contact components
Surface of material: special copper alloy

Processing:
Special tools for large scale wiring available on request

Marking material

wiecon

Material:
Polyamide 66/6
Colour: black figures on a white background



Marking strips pitch 10 mm

Type	Part No.	Box Qty
9705 A/5/10/5 B	04.842.5553.0	25

3 digit marker tag

Type	Part No.	Box Qty
unmarked		
9705 A	04.242.0850.0	500
marked*		
9705 AB	04.842.0850.0	500
* indicate required marking tag in addition to part number		
Packing unit = 500 tags		

single tag

Marking strips pitch 10 mm

Type	Part No.	Box Qty
unmarked		
9705 A/5/10	04.242.5053.0	25
marked*		
9705 A/5/10 B	04.842.5053.0	25
with enlarged labelling area		
9705 AL/5/10	04.242.5153.0	25
* indicate required marking tag in addition to part number		
Packing unit = 25 strips = 250 tags		

Marking tags for WEB empty housing

04.242.1050.0 200

8 digit marker tag

Type	Part No.	Box Qty
unmarked		
9705 AL	04.242.1553.0	500
marked*		
9705 ALB	04.842.1553.0	500
* indicate required marking tag in addition to part number		
Packing unit = 500 tags		

single tag

Marking strips pitch 5 mm

Type	Part No.	Box Qty
9705 A/5/9 B	04.842.4953.0	25
Marking of the strips: 1 ... 9		
Packing unit = 25 strips = 225 tags		

Marking branch
with 10 marker tags

witecon



Material: Polyamide 66/6 white, unmarked	marking on each branch	Type	Part No.	Box Qty
		9704 A	04.241.1150.0	25
marked with the same number	1 1 1 1 1 1 1 1 1 1	9704 A/1 B	04.841.1150.0	25
	2 2 2 2 2 2 2 2 2 2	9704 A/2 B	04.841.1250.0	25
	3 3 3 3 3 3 3 3 3 3	9704 A/3 B	04.841.1350.0	25
	4 4 4 4 4 4 4 4 4 4	9704 A/4 B	04.841.1450.0	25
	5 5 5 5 5 5 5 5 5 5	9704 A/5 B	04.841.1550.0	25
	6 6 6 6 6 6 6 6 6 6	9704 A/6 B	04.841.1650.0	25
	7 7 7 7 7 7 7 7 7 7	9704 A/7 B	04.841.1750.0	25
	8 8 8 8 8 8 8 8 8 8	9704 A/8 B	04.841.1850.0	25
	9 9 9 9 9 9 9 9 9 9	9704 A/9 B	04.841.1950.0	25
	0 0 0 0 0 0 0 0 0 0	9704 A/0 B	04.841.2050.0	25
	marked with consecutive numbers	1 2 3 4 5 6 7 8 9 0	9704 A/1-0 B	04.841.2150.0
marked with identical uppercase letters	A A A A A A A A A A	9704 A/AG B	04.841.2250.0	25
	B B B B B B B B B B	9704 A/BG B	04.841.2350.0	25
	C C C C C C C C C C	9704 A/CG B	04.841.2450.0	25
	D D D D D D D D D D	9704 A/DG B	04.841.2550.0	25
	E E E E E E E E E E	9704 A/EG B	04.841.2650.0	25
	F F F F F F F F F F	9704 A/FG B	04.841.2750.0	25
	G G G G G G G G G G	9704 A/GG B	04.841.2850.0	25
	H H H H H H H H H H	9704 A/HG B	04.841.2950.0	25
	I I I I I I I I I I	9704 A/IG B	04.841.3050.0	25
	J J J J J J J J J J	9704 A/JG B	04.841.3150.0	25
	K K K K K K K K K K	9704 A/KG B	04.841.3250.0	25
	L L L L L L L L L L	9704 A/LG B	04.841.3350.0	25
	M M M M M M M M M M	9704 A/MG B	04.841.3450.0	25
	N N N N N N N N N N	9704 A/NG B	04.841.3550.0	25
	O O O O O O O O O O	9704 A/OG B	04.841.3650.0	25
	P P P P P P P P P P	9704 A/PG B	04.841.3750.0	25
	Q Q Q Q Q Q Q Q Q Q	9704 A/QG B	04.841.3850.0	25
	R R R R R R R R R R	9704 A/RG B	04.841.3950.0	25
	S S S S S S S S S S	9704 A/SG B	04.841.4050.0	25
	T T T T T T T T T T	9704 A/TG B	04.841.4150.0	25
	U U U U U U U U U U	9704 A/UG B	04.841.4250.0	25
	V V V V V V V V V V	9704 A/VG B	04.841.4350.0	25
	W W W W W W W W W W	9704 A/WG B	04.841.4450.0	25
	X X X X X X X X X X	9704 A/XG B	04.841.4550.0	25
	Y Y Y Y Y Y Y Y Y Y	9704 A/YG B	04.841.4650.0	25
	Z Z Z Z Z Z Z Z Z Z	9704 A/ZG B	04.841.4750.0	25
marked with identical lowercase letters	a a a a a a a a a a	9704 A/AK B	04.841.4850.0	25
	b b b b b b b b b b	9704 A/BK B	04.841.4950.0	25
	c c c c c c c c c c	9704 A/CK B	04.841.5050.0	25
	d d d d d d d d d d	9704 A/DK B	04.841.5150.0	25
	e e e e e e e e e e	9704 A/EK B	04.841.5250.0	25
	f f f f f f f f f f	9704 A/FK B	04.841.5350.0	25
	g g g g g g g g g g	9704 A/GK B	04.841.5450.0	25
	h h h h h h h h h h	9704 A/HK B	04.841.5550.0	25
	i i i i i i i i i i	9704 A/IK B	04.841.5650.0	25
	j j j j j j j j j j	9704 A/JK B	04.841.5750.0	25
	k k k k k k k k k k	9704 A/KK B	04.841.5850.0	25
	l l l l l l l l l l	9704 A/LK B	04.841.5950.0	25
	m m m m m m m m m m	9704 A/MK B	04.841.6050.0	25
	n n n n n n n n n n	9704 A/NK B	04.841.6150.0	25
	o o o o o o o o o o	9704 A/OK B	04.841.6250.0	25
	p p p p p p p p p p	9704 A/PK B	04.841.6350.0	25
	q q q q q q q q q q	9704 A/QK B	04.841.6450.0	25
	r r r r r r r r r r	9704 A/RK B	04.841.6550.0	25
	s s s s s s s s s s	9704 A/SK B	04.841.6650.0	25
	t t t t t t t t t t	9704 A/TK B	04.841.6750.0	25
	u u u u u u u u u u	9704 A/UK B	04.841.6850.0	25
	v v v v v v v v v v	9704 A/VK B	04.841.6950.0	25
	w w w w w w w w w w	9704 A/WK B	04.841.7050.0	25
	x x x x x x x x x x	9704 A/XK B	04.841.7150.0	25
	y y y y y y y y y y	9704 A/YK B	04.841.7250.0	25
	z z z z z z z z z z	9704 A/ZK B	04.841.7350.0	25
marked with the same symbol	+ + + + + + + + + +	9704 A/+ B	04.841.7450.0	25
	- - - - - - - - - -	9704 A/- B	04.841.7550.0	25
	/ / / / / / / / / /	9704 A// B	04.841.7650.0	25
	9704 A/. B	04.841.7750.0	25
1 set of identical numbers = 10 x 25 branches = 2500 digits	1 1 1 ... 0 0 0	111 to 000	04.841.9050.0	1
1 set of uppercase letters = 26 x 25 branches = 6500 letters	A A A ... Z Z Z	A to Z GB	04.841.9150.0	1
1 set of lowercase letters = 26 x 25 branches = 6500 letters	a a a ... z z z	a to z KB	04.841.9250.0	1