

78 Electronics Super-Knips



DIN ISO 9654



78 03 125



78 13 125



78 23 125



78 31 125



78 41 125



78 71 125



78 61 125



Modell 78 61 125:

- ▶ also suitable for cutting glass fibre cables (fibre optics)

- ▶ precision pliers for ultra fine cutting work, e. g. in electronics and fine mechanics
- ▶ precision-ground cutting edges without bevel for flush cutting
- ▶ precision shaped tips also cut close sitting wire from 0.2 mm dia.
- ▶ joint with stainless steel rivet
- ▶ extremely smooth movement for minimum operator fatigue
- ▶ with opening spring and restricted opening

Style 0; 1; 2:

- ▶ INOX - stainless steel
- ▶ cutting edge hardness approx. 54 HRC

Style 2:

- ▶ with 60° angled blades

Style 3; 4; 6; 7:

- ▶ special tool steel

Style 3; 4:

- ▶ cutting edge hardness approx. 60 HRC

Style 1; 4; 7:

- ▶ with lead catcher - no uncontrolled loss of cut wire ends

Style 6; 7:

- ▶ cutting edges additionally induction hardened, cutting edge hardness approx. 64 HRC

KNIPLEX
special

KNIPLEX Super-Knips have precision ground cutting edges for clean, flush cutting. The very smooth joint and the opening spring provide high operation comfort.



Angled blades for clean cut also in confined areas

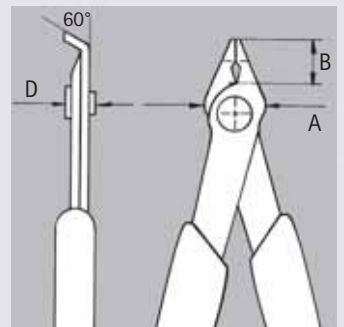
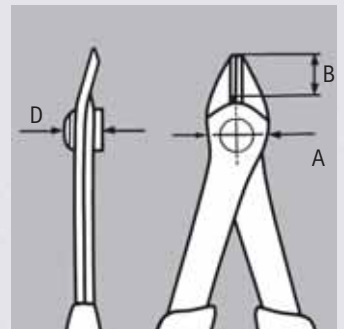

Article-No.	EAN-Code	Style	Head	Handles	Dimensions			Cutting capacities			g	
					B	A	D	∅ mm	∅ mm	∅ mm		
	Length mm	Code	all pliers with all pliers with									
		4003773-										
78 03 125		035381	0	INOX	with two-colour	9.0	13.5	7.5	0.2-1.6	1.0	-	45
78 13 125		035398	1	INOX	dual component handles	9.0	13.5	7.5	0.2-1.6	1.0	-	50
78 23 125		043096	2	INOX		5.5	13.5	7.5	0.2-1.0	0.6	-	45
78 31 125		039778	3	burnished		9.0	12.5	7.5	0.2-1.0	-	-	50
78 41 125		040767	4	burnished		9.0	12.5	7.5	0.2-1.0	-	-	50
78 61 125		035404	6	burnished		9.0	13.5	7.5	0.2-1.6	1.2	0.6	45
78 71 125		043799	7	burnished		9.0	13.5	7.5	0.2-1.6	1.2	0.6	50