

Cree® XLamp® MC-E LED Data Sheet

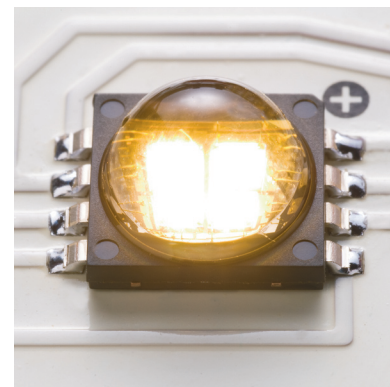

FEATURES

- Industry's first lighting-class multi-chip LED
- Highest XLamp lumen density (lm/mm^2)
- Individually addressable LEDs
- Available in white (2,600 K to 10,000 K CCT)
- Maximum drive current: 700 mA per LED die
- Lowest XLamp thermal resistance: $3^\circ\text{C}/\text{W}$
- Electrically neutral thermal path

Table of Contents

Flux Characteristics.....	2
Characteristics - Complete Package.....	2
Characteristics - Per LED Die.....	2
Relative Spectral Power Distribution ($I_f = 350 \text{ mA}$).....	3
Relative Flux vs Junction Temperature ($I_f = 350 \text{ mA}$).....	3
Electrical Characteristics ($T_j = 25^\circ\text{C}$).....	4
Relative Luminous Flux vs. Current ($T_j = 25^\circ\text{C}$).....	4
Typical Spatial Radiation Pattern.....	5
Mechanical Dimensions.....	6
Notes.....	8

Flux Characteristics

The following tables provide several base order codes for XLamp MC-E. It is important to note that the base order codes listed here are a subset of the total available order codes for the product family. For more order codes, as well as a complete description of the order-code nomenclature, please consult the XLamp MC-E Binning and Labeling document.

Color	CCT Range		Base order codes Min Luminous Flux (lm) @ 350 mA*		Order Code
	Min.	Max.	Group	Flux (lm)	
Cool White	5,000 K	10,000 K	K	370	MCE4WT-A2-0000-000K01
			M	430	MCE4WT-A2-0000-000M01
Neutral White	3,700 K	5,000 K	J	320	MCE4WT-A2-0000-000JE4
			K	370	MCE4WT-A2-0000-000KE4
Warm White	2,600 K	3,700 K	G	240	MCE4WT-A2-0000-000GE7
			H	280	MCE4WT-A2-0000-000HE7

Notes:

- Cree maintains a tolerance of $\pm 7\%$ on flux and power measurements.
- Typical CRI for cool white and neutral white (3,700 K - 10,000 K CCT) is 75.
- Typical CRI for warm white (2,600 K - 3,700 K CCT) is 80.
- Flux and chromaticity are measured with each LED die connected to independent drive circuits at 350 mA. The flux and chromaticity are measured with all LEDs lit simultaneously.

Characteristics - Complete Package

The following table lists the product characteristics for the XLamp MC-E LED package.

Characteristics	Unit	Minimum	Typical	Maximum
Thermal Resistance, junction to solder point	$^{\circ}\text{C}/\text{W}$		3	
Viewing Angle (FWHM)	degrees		110	
ESD Classification (HBM per Mil-Std-883D)			Class 2	

Characteristics - Per LED Die

The following table lists the product characteristics of each individual LED die within the XLamp MC-E LED package.

Characteristics	Unit	Minimum	Typical	Maximum
Temperature Coefficient of Voltage	$\text{mV}/^{\circ}\text{C}$		-4	
DC Forward Current	mA			700
Reverse Voltage	V			5
Forward Voltage (@ 350 mA)	V		3.2	3.9
Forward Voltage (@ 700 mA)	V		3.5	

Relative Spectral Power Distribution ($I_F = 350 \text{ mA}$)

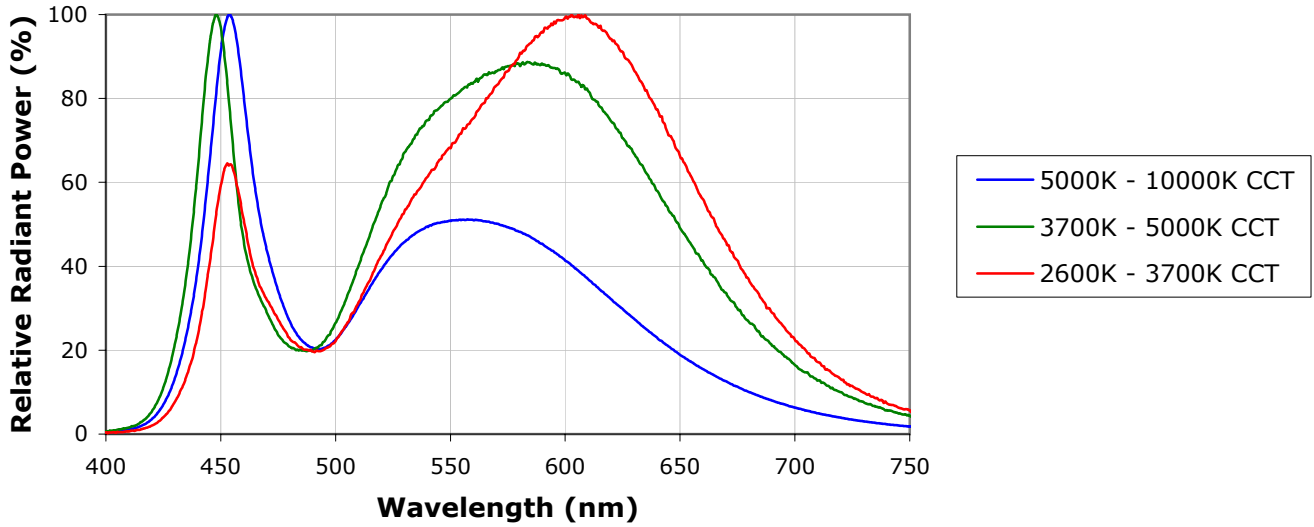

Relative Flux vs Junction Temperature ($I_F = 350 \text{ mA}$)

The following graph represents typical performance of XLamp MC-E LEDs with all four LEDs driven in series at 350 mA.

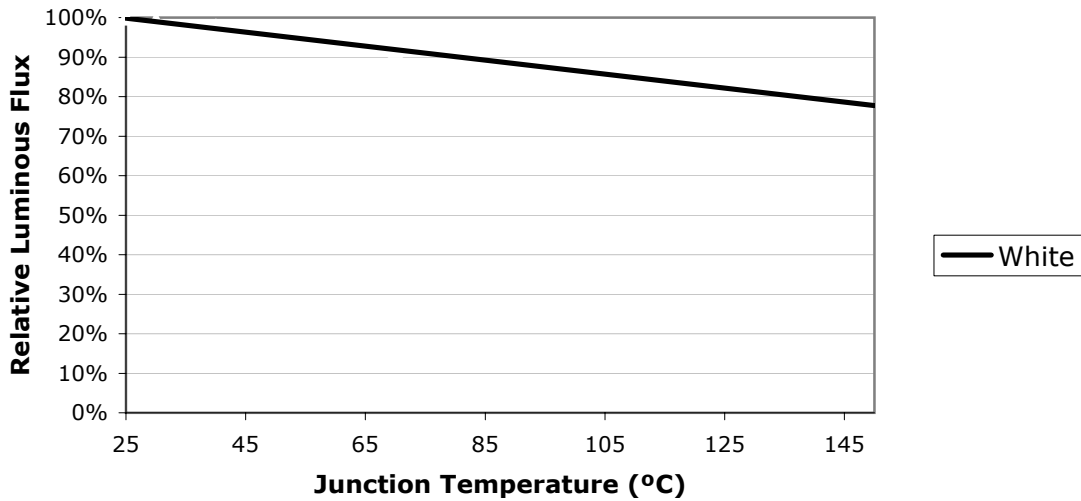

Electrical Characteristics ($T_j = 25^\circ\text{C}$)

The following graph shows the electrical characteristics of one LED die in the XLamp MC-E LED.

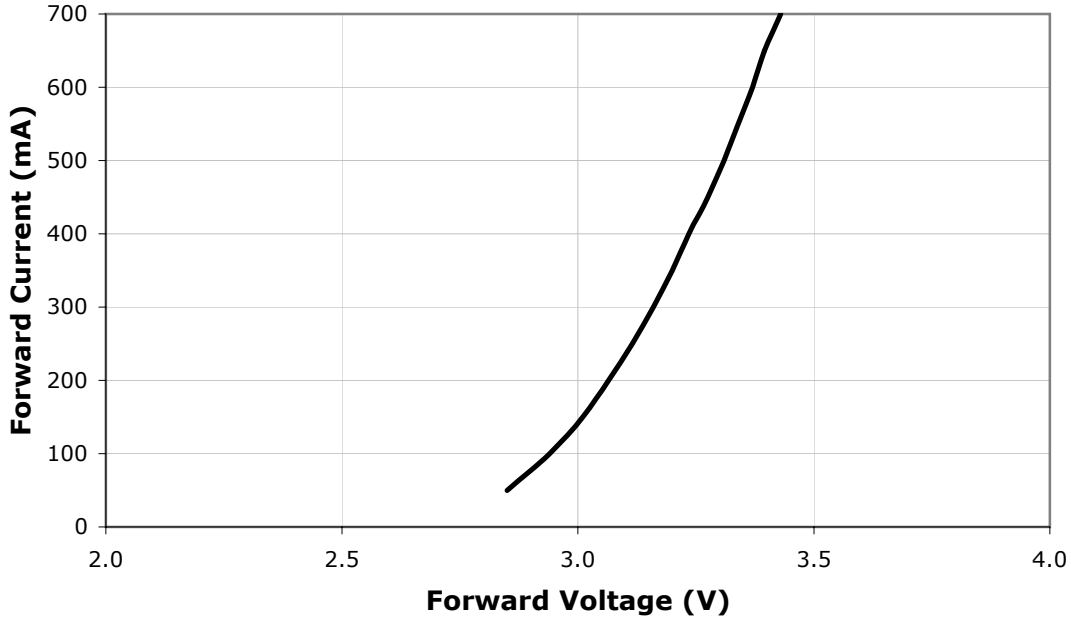

Relative Luminous Flux vs. Current ($T_j = 25^\circ\text{C}$)

The following graph represents typical performance of XLamp MC-E LEDs with all four LEDs driven in series.

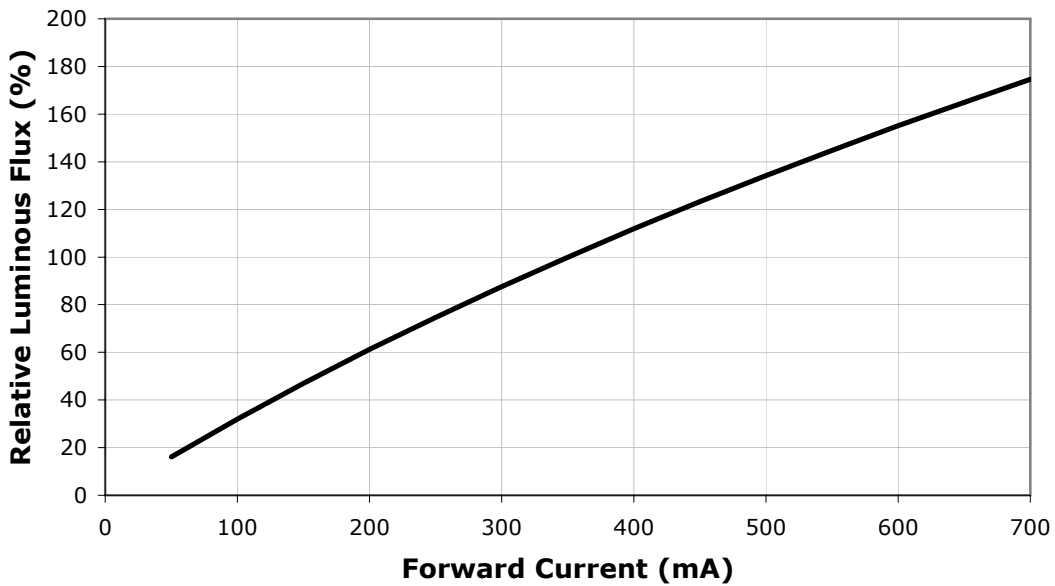

Typical Spatial Radiation Pattern

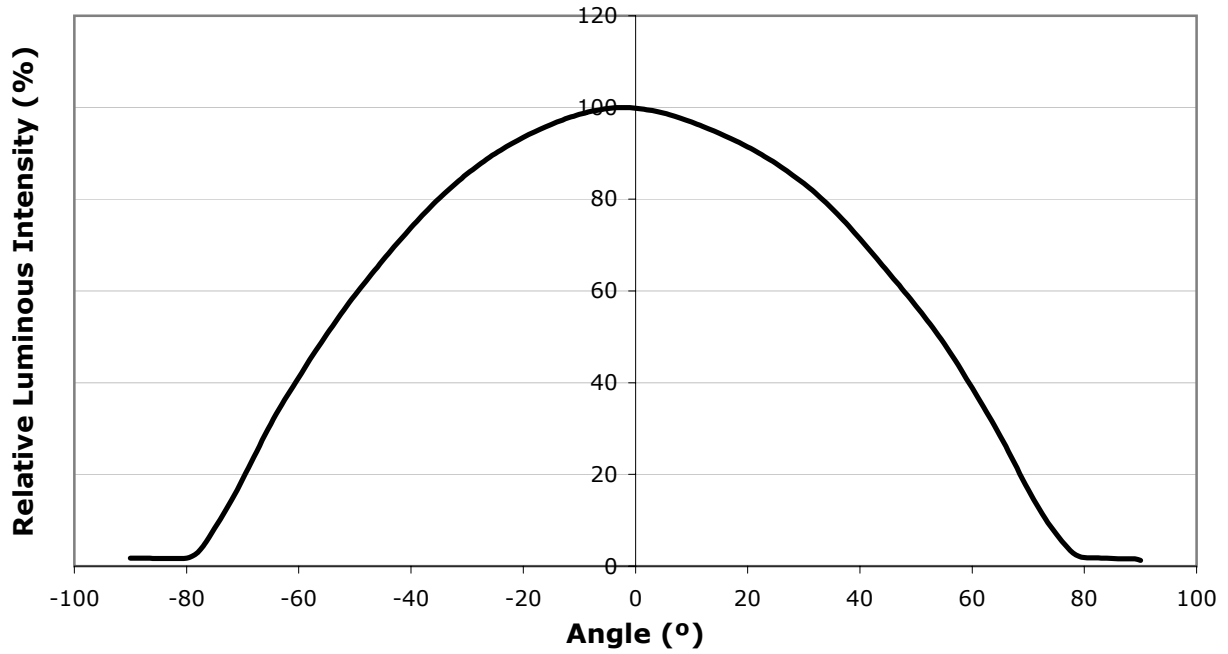

Mechanical Dimensions

All measurements are ± 0.1 mm unless otherwise indicated.

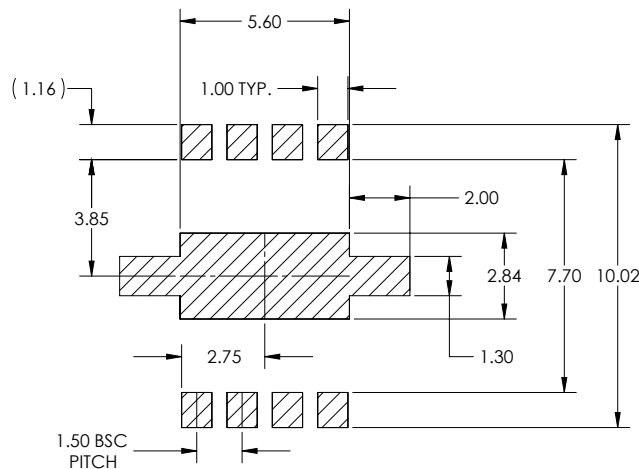
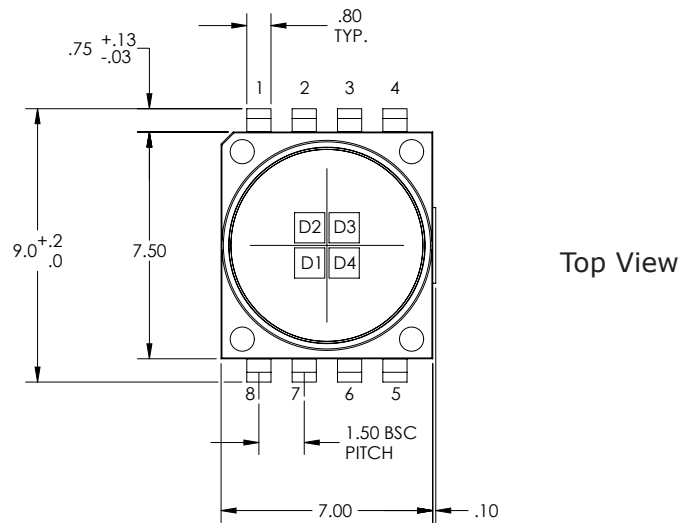
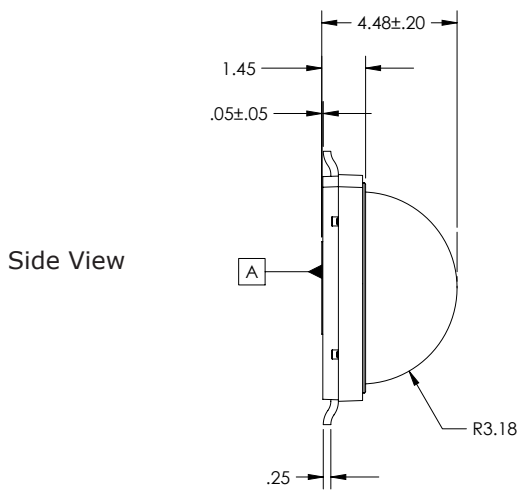
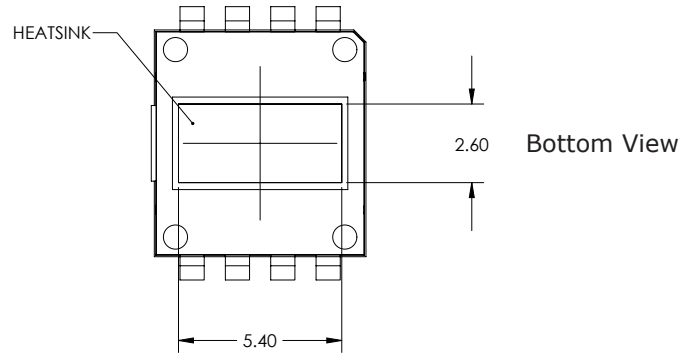
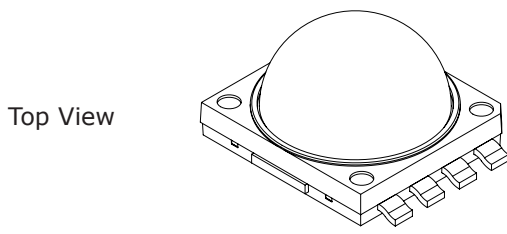

RECOMMENDED PCB SOLDER PAD

1. Tolerances: ± 0.10
2. Solder mask windows must be $.05$ mm bigger than PCB Solder Pad.

Mechanical Dimensions continued

All measurements are $\pm .1\text{mm}$ unless otherwise indicated.

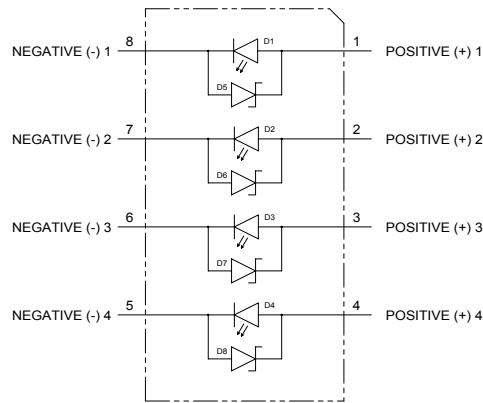

Notes

Moisture Sensitivity

XLamp LEDs are shipped in sealed, moisture-barrier bags (MBB) designed for long shelf life. If XLamp LEDs are exposed to moist environments after opening the MBB packaging but before soldering, damage to the LED may occur during the soldering operation. The following derating table defines the maximum exposure time (in days) for an XLamp LED in the listed humidity and temperature conditions. LEDs with exposure time longer than the time specified below must be baked according to the baking conditions listed below.

Temperature	Maximum Percent Relative Humidity						
	30%	40%	50%	60%	70%	80%	90%
30°C	9	5	4	3	1	1	1
25°C	12	7	5	4	2	1	1
20°C	17	9	7	6	2	2	1

Baking Conditions

It is not necessary to bake all XLamp LEDs. Only the LEDs that meet all of the following criteria must be baked:

1. LEDs that have been removed from the original MBB packaging
2. LEDs that have been exposed to a humid environment longer than listed in the Moisture Sensitivity section above
3. LEDs that have not been soldered

LEDs should be baked at 80°C for 24 hours. LEDs may be baked on the original reels. Remove LEDs from MBB packaging before baking. Do not bake parts at temperatures higher than 80°C. This baking operation resets the exposure time as defined in the Moisture Sensitivity section above.

Storage Conditions

XLamp LEDs that have been removed from original MBB packaging but not soldered yet should be stored in a room or cabinet that will maintain an atmosphere of $25 \pm 5^\circ\text{C}$ and no greater than 10% RH (relative humidity). For LEDs stored in these conditions, storage time does not add to exposure time as defined in the Moisture Sensitivity section above.

Vision Advisory Claim

Users should be cautioned not to stare at the light of this LED product. The bright light can damage the eye.