

TOGGLE HAND PRESS

MODEL P1200PR 714-8793

With 15 dan handle force the output force is:

| dan | mm |
|-----|-----------------|
| 705 | Fully retracted |
| 167 | 5 mm extended |
| 90 | 10 mm |
| 73 | 15 mm |
| 70 | 20 mm |
| 72 | 25 mm |
| 85 | 30 mm |
| 100 | 35 mm |
| 110 | 40 mm |
| 150 | 45 mm |
| 220 | 48 mm |
| 290 | 49 mm |
| 930 | Fully extended |

Type:
Bench mounted manual toggle press.

Intended hotchick force:
1200 dan.

Weight:
7.35 Kg.

Quality Features:

- S.G. Iron framecasting.
- precision ground steel plunger.
- fixed height work head.

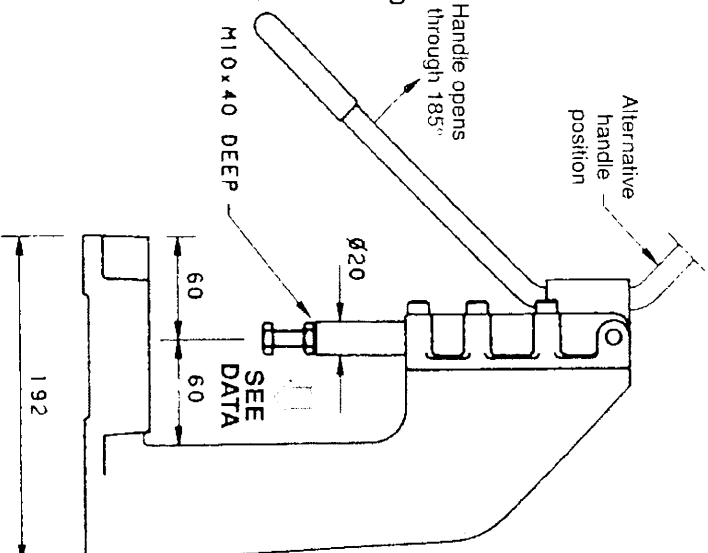
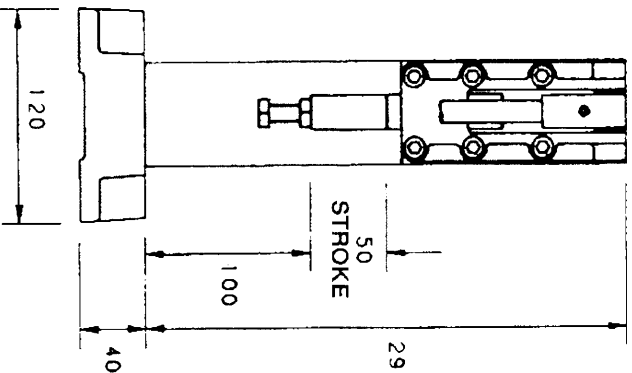
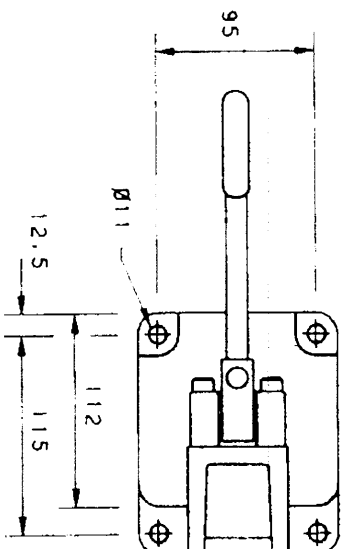
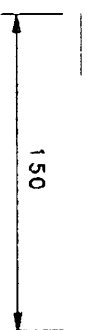
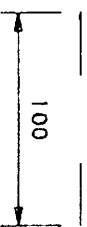
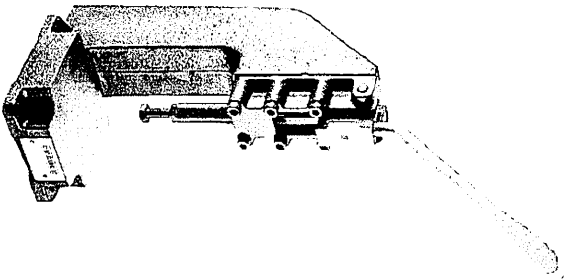

H.M.C BRAUER LTD

25/02 '03 16:47 FAX 01908641628

001

E-Mail: sales@brauer.co.uk
www.brauer.co.uk