

Type: BZCT035, 070, 120 & 210

Circular Toroids

- ❑ For use in conjunction with Broyce "Type A" Earth Leakage Relays
- ❑ Designed to detect leakage current and transmit a proportional signal to an Earth Leakage Relay
- ❑ Surface mounting with 4 fixing slots (BZCT210 supplied with separate mounting feet)
- ❑ Slim design



INSTALLATION NOTE



Installation work must be carried out by qualified personnel.

- BEFORE INSTALLATION, ISOLATE THE SUPPLY TO THE CABLES THAT ARE TO BE PASSED THROUGH THE TOROID.
- Installation of the toroid, along with the Earth Leakage Relay must be carried out in accordance with the latest wiring practices and regulations.

FUNCTION DIAGRAM

Typical connection examples are shown below.

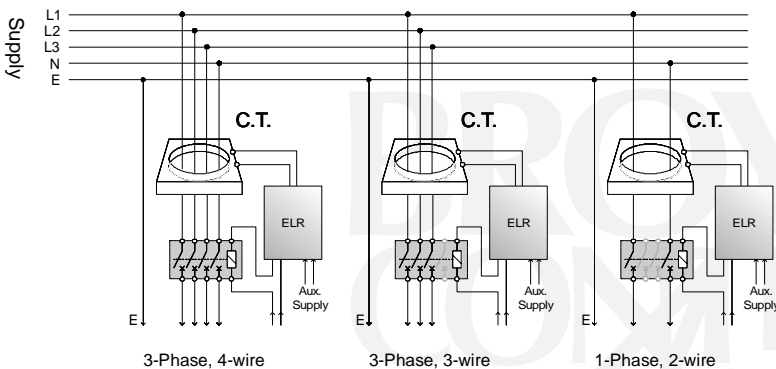

TECHNICAL SPECIFICATION

Size availability* and part number:

35mm Ø (BZCT035)
70mm Ø (BZCT070)
120mm Ø (BZCT120)

* internal diameter

210mm Ø (BZCT210)

Rated system voltage:

720VAC

Insulation level:

3kVAC

Current ratio:

1/1000

Maximum permissible current:

1 kA continuous
5kA for 1.5Sec.
100kA for 0.05Sec.

Minimum IΔn setting on

Earth Leakage Relay for

each type of toroid:
0.03A - 35 and 70mm Ø
0.1A - 120mm Ø
0.3A - 210mm Ø

Distance between

toroid and relay:

50 metres (max.)

Ambient temp:

-20 to +60°C

Relative humidity:

+95%

Housing:

Grey ABS

Mounting option:

Panel mount only using fixing slots provided (BZCT210 requires separate mounting feet as supplied)

Terminal conductor size:

≤ 2.5mm² solid
≤ 1.5mm² stranded

Approvals:

CE Compliant.
Conforms to: IEC44-1, IEC185 & BS7676

INSTALLATION DO's and DONT's

- Correct installation of the Earth Leakage Relay and toroid should ensure trouble free operation, in particular, if this document is followed.

1. Always ensure the Earth conductor DOES NOT pass through the toroid. If it is unavoidable, the Earth must be routed back through the toroid again and around, as shown in Fig.2 below.
2. As a rule, select a toroid that has an inside diameter which is twice that or greater than the outsider diameter of the cable(s) to be passed through.
3. Ensure the cable is central in the toroid.
4. Place the toroid on a straight section of cable, not near a bend.
5. Keep the cable and toroid away from intense magnetic fields from nearby equipment.
6. DO NOT pass individual conductors through separate toroids, as shown in Fig. 3.

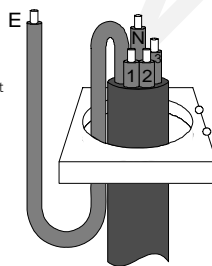

Fig. 1

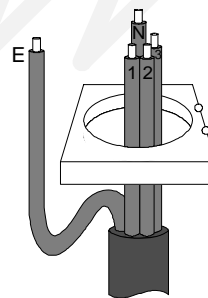

Fig.2

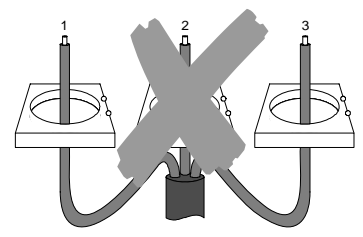
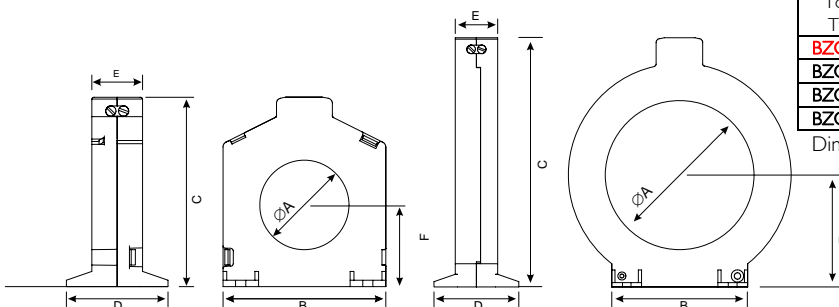

Fig.3

DIMENSIONS



BZCT035

BZCT070, 120 & 210mm

Toroid Type:	AØ	B	C	D	E	F	Weight
BZCT035	35	64	74	40	20	32	77g
BZCT070	70	105	117	40	20	53	135g
BZCT120	120	155	170	40	20	80	265g
BZCT210	210	149	304	60*	30	145	1300g

Dimensions in mm

*exc. mounting feet

Broyce Control Ltd., Pool Street, Wolverhampton, West Midlands WV2 4HN. England

BZCT-3-A

Telephone: +44 (0) 1902 773746 Facsimile: +44 (0) 1902 420639 Email: sales@broycecontrol.com Web: http://www.broycecontrol.com

The information provided in this literature is believed to be accurate (subject to change without prior notice); however, use of such information shall be entirely at the user's own risk.