

REV.	MODIFICATION.	DATE	DRN
01	Production Release	03/01/08	TC

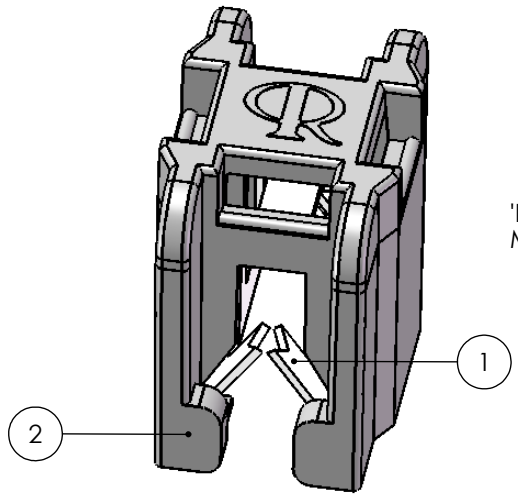

'FTH-31-01' WITH CABLE TIE MOUNTED ACROSS PANEL

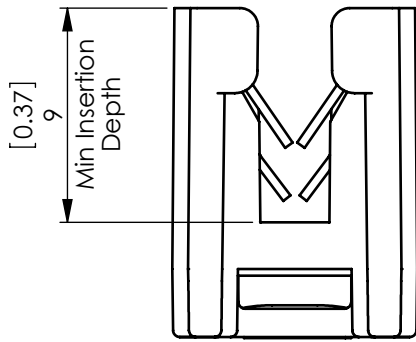
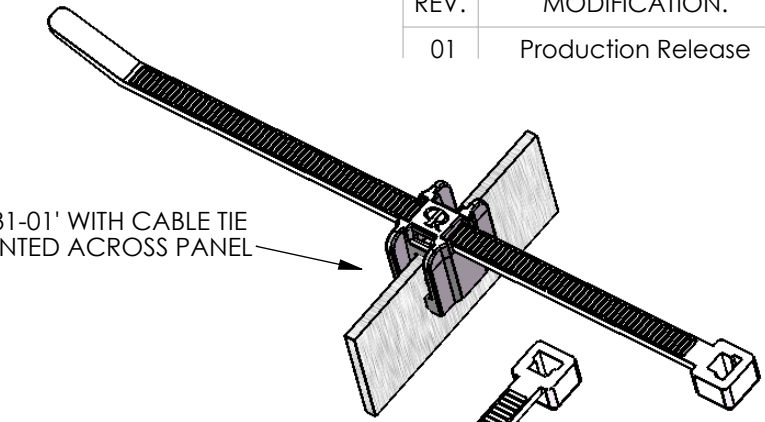

'FTH-31-01' WITH CABLE TIE MOUNTED ALONG PANEL

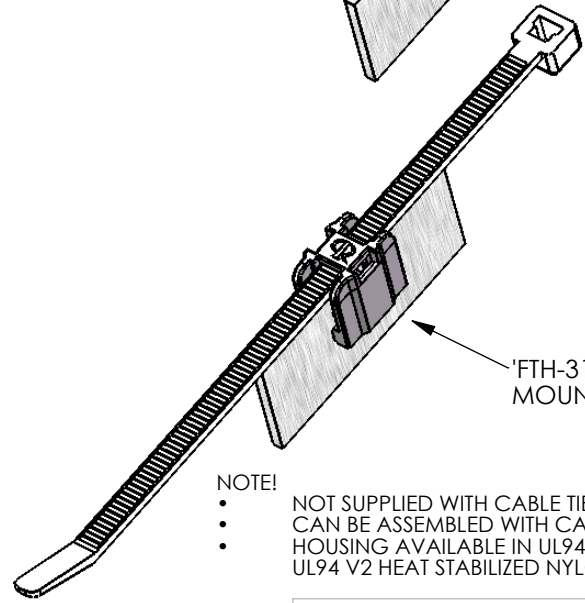

NOTE!

-
-
-

NOT SUPPLIED WITH CABLE TIES - TO BE ORDERED SEPARATELY
 CAN BE ASSEMBLED WITH CABLE TIE BY SPECIAL ORDER ONLY
 HOUSING AVAILABLE IN UL94 V0 NYLON 6/6 (RMS-19) AND
 UL94 V2 HEAT STABILIZED NYLON 6/6 (RMS-47) BY SPECIAL ORDER

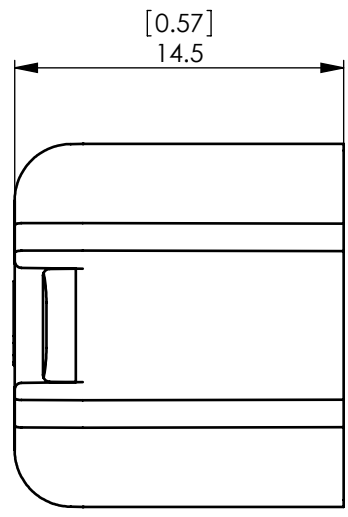
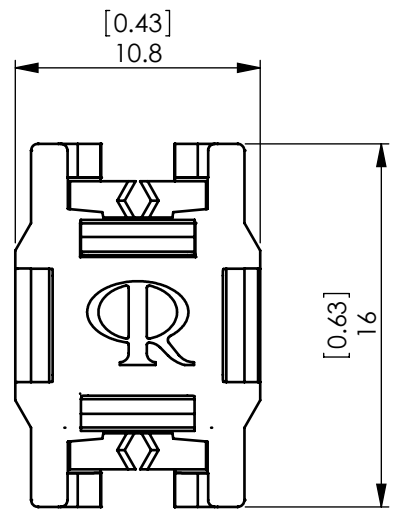

INFORMATION CONTAINED IN THIS DOCUMENT IS CONFIDENTIAL TO RICHCO INTERNATIONAL Co. Ltd. AND MAY NOT BE DISCLOSED OR REPRODUCED IN WHOLE OR PART WITHOUT THEIR WRITTEN CONSENT.



ALL DIMENSIONS IN mm [INCH]
 SEE ENGINEERING DRAWINGS FOR TOLERANCE INFORMATION

THIRD ANGLE

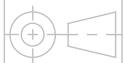

ITEM	DESCRIPTION	MATERIAL	COLOUR	PANEL THICKNESS	RETENTION FORCE	CABLE TIES ACCEPTED
2	HOUSING	NYLON 6/6 UL94 V2 (RMS-01)	BLACK	0.8 - 3 [0.03 - 0.12]	TO STEEL PANEL: Minimum 25N 0.8 [0.03] Panel Minimum 45N 3 [0.12] Panel	WITE/WIT-30 / 40 / 50 QTE-18 / 30 / 50
1	METAL CLIP	STAINLESS STEEL (RMS-365) GRADE 304 (1.4301)	TYPE '2B' BRIGHT FINISH		TO PLASTIC PANEL: Minimum 150N 2.4 - 3 [0.09 - 0.12]	

MATERIAL: SEE TABLE				COLOR: SEE TABLE	
DESCRIPTION: EDGE CLIP TIE HOLDER				PART No: FTH-31-01	
DRG No: 07-073		NPR No: 2005-205-3		Mass:(g) 1.4	SHEET SIZE A4
DRN TC	DATE 10/01/06	CHKD JC	DATE 31/07/07	SCALE NTS	SHEET No. 1 OF 1