

New Information  
March 2008

### Contents

<i>Description</i>	<i>Page</i>
Overview .....	1
Contactors .....	2
Overload Relays (Bimetal) .....	3
Starters .....	5
Electronic Overload Relays .....	7
Reversing Contactors .....	9
Contactor Accessories .....	10
Contactor Coils .....	11
Manual Motor Protectors .....	12
Combination Style Starters .....	13

### Overview

This training module focuses on Eaton's newest line of IEC Power Control, called **XT**. The **XT** line consists of the following components:

- Contactors
- Overload Relays (Bimetal and Electronic)
- Starters
- Coils and Accessories
- Manual Motor Protectors
- Combination Style Controllers

Power Control products consist of devices that are used to start, stop and protect motors. There are several types of power control devices that are used for various applications, see **Table 1**.

**Table 1. IEC Power Control Devices**

Type	Description	Cost	Electrical Operations	Common Approvals	Common Applications
Reduced Voltage	Soft starters or drives that gradually start and stop motors.	High	3 to 4 million	UL, CSA	High inertia motors or fragile applications
NEMA	Contactors and overload relays with a complete line of accessories and ratings. Large in size.	Moderate	3 to 4 million	UL, CSA	Motor control centers
IEC	<b>Contactors, overload relays, and MMPs with a complete line of accessories and ratings. Small in size.</b>	Low	1.4 million	<b>UL, CE, CSA, KEMA, CCC, etc.</b>	<b>OEM machine control applications</b>
Definite Purpose (DP)	Contactors and overload relays with a limited line of accessories and ratings. Small size.	Low	200 to 300 thousand	UL, HACR	Heating, AC, and Refrigeration

IEC Power Control devices are a very common choice because they provide a good balance of features, ratings, and performance, all at an economical price. IEC contactors are designed according to a global standard called International Electrotechnical Commission (IEC). This global standard enables power control and other devices to share a common base

for design, ratings, and classification. Although IEC is a global system, each country has its own set of governing standards. For example, Underwriter's Laboratories (UL) is an organization that writes safety standards for electrical products in the U.S. In order for IEC contactors to be used in the U.S., they must also be tested and approved by UL.



## Contactors

Contactors are devices used to start and stop motors. They include a set of contacts that open and close when the coil is energized. When contacts close, power can flow to the motor enabling the motor to operate. Unlike a manual switch, contactors can be operated remotely. This means an operator can

start a motor without opening the control panel by using pushbutton controls, or a PLC can operate the contactor.

Table 2 shows the catalog numbering system for **XT** contactors, and Table 3 lists the IEC and UL ratings that are used when selecting the **XT** contactor.

As you can see, the B-frame and C-frame contactors include either a NO or a NC auxiliary contact. Auxiliary contacts will be discussed in a later section.

Table 2. Catalog Numbering System — Contactors

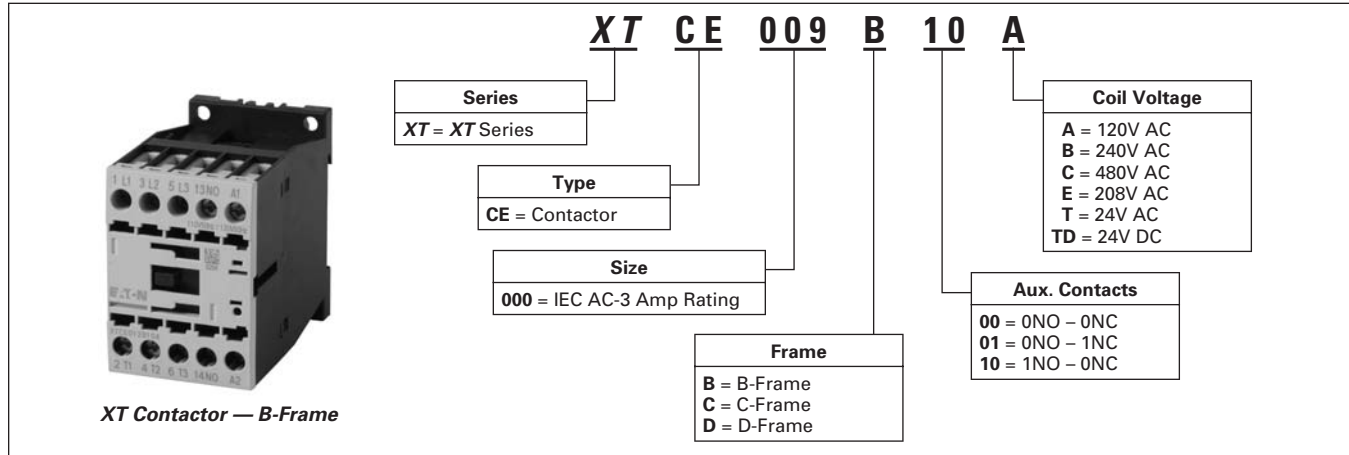

Table 3. Contactor Selection, Frames B – D

IEC Ratings						UL Ratings							Aux. Contacts	Catalog Number — Screw Terminals
$I_e$ (A)	$I_e = I_{th}$ (A)	Maximum kW Ratings AC-3				Maximum 3-Phase Motor Rating, UL/CSA								
AC-3	AC-1 (60°C)	3-Phase Motors 50 – 60 Hz				1-Phase hp Ratings			3-Phase hp Ratings					
		220/230V	380/400V	415V	660/690V	115V	200V	230V	200V	230V	460V	575V		
<b>Frame B</b>														
7	20	2.2	3	4	3.5	1/4	3/4	1	1-1/2	2	3	5	1NO	XTCE007B10_
7	20	2.2	3	4	3.5	1/4	3/4	1	1-1/2	2	3	5	1NC	XTCE007B01_
9	20	2.5	4	5.5	4.5	1/2	1	1-1/2	3	3	5	7-1/2	1NO	XTCE009B10_
9	20	2.5	4	5.5	4.5	1/2	1	1-1/2	3	3	5	7-1/2	1NC	XTCE009B01_
12	20	3.5	5.5	7	6.5	1	2	2	3	3	10	10	1NO	XTCE012B10_
12	20	3.5	5.5	7	6.5	1	2	2	3	3	10	10	1NC	XTCE012B01_
15.5	20	4	7.5	8	7	1	2	3	5	5	10	10	1NO	XTCE015B10_
15.5	20	4	7.5	8	7	1	2	3	5	5	10	10	1NC	XTCE015B01_
<b>Frame C</b>														
18	35	5	7.5	10	11	2	2	3	5	5	10	15	1NO	XTCE018C10_
18	35	5	7.5	10	11	2	2	3	5	5	10	15	1NC	XTCE018C01_
25	40	7.5	11	14.5	14	2	3	5	7-1/2	7-1/2	15	20	1NO	XTCE025C10_
25	40	7.5	11	14.5	14	2	3	5	7-1/2	7-1/2	15	20	1NC	XTCE025C01_
32	40	10	15	18	17	3	5	5	10	10	20	25	1NO	XTCE032C10_
32	40	10	15	18	17	3	5	5	10	10	20	25	1NC	XTCE032C01_
<b>Frame D</b>														
40	50	12.5	18.5	24	23	3	5	7-1/2	10	15	30	40	—	XTCE040D00_
50	65	15.5	22	30	30	3	7-1/2	10	15	20	40	50	—	XTCE050D00_
65	80	20	30	39	35	5	10	15	20	25	50	60	—	XTCE065D00_

**Practice:**

Select an **XT** contactor for a 10 hp, 460V motor with a 1NO auxiliary and a 120V AC Coil:

What is the frame size for this contactor?

The AB part number 100-C16D10 is rated for 10HP at 460V (UL) and 16 amps per AC-3 (IEC) and has a 120V AC coil and a 1NO aux. Cross reference this part number according to UL and then to IEC:

UL:

IEC:

**Overload Relays (Bimetal)**

Overload relays are devices that monitor the current going to the motor. If too much current is flowing to the motor, there could be a problem with the motor or the load it's pulling. Continued operation in this condition could damage the motor.

Overload relays are designed to take a contactor offline in the event of an overcurrent situation. Overload relays are selected based on the desired ampere protection level for the motor. When selecting overload relays, it is important to be sure to match the overload frame size with the contactor frame size, so that the overload will mount correctly to the contactor.

Overload relays have a current range that is set to the appropriate protection level by adjusting the dial on the face of the overload relay. It is best to select an overload that has a range where the desired full load current setting is in the middle to lower portion of the range if possible, especially if the exact full load current is unknown. This way, the end user will be able to adjust the overload relay per regulation.

Overloads are selected based on the full load amp (FLA or FLC) and the service rating of the motor. If the service factor is less than 1.15, then the target amp setting is 0.9 times the

FLA. If the service factor is 1.15 or greater, then the target amp setting is the FLA. Service factors of 1.15 are very common.

For example, if a motor has an 11.6 FLA and a 1.10 service factor, the target amp setting would be 10.4. Assuming the contactor used for this application is an **XT** B-frame, the overload selection would be part number **XTOB012BC1**, which has an overload setting range of 9 – 12 amps. **Tables 4** and **5** show the overload numbering system and the selection table.

**Table 4. Catalog Numbering System — Overload Relay**

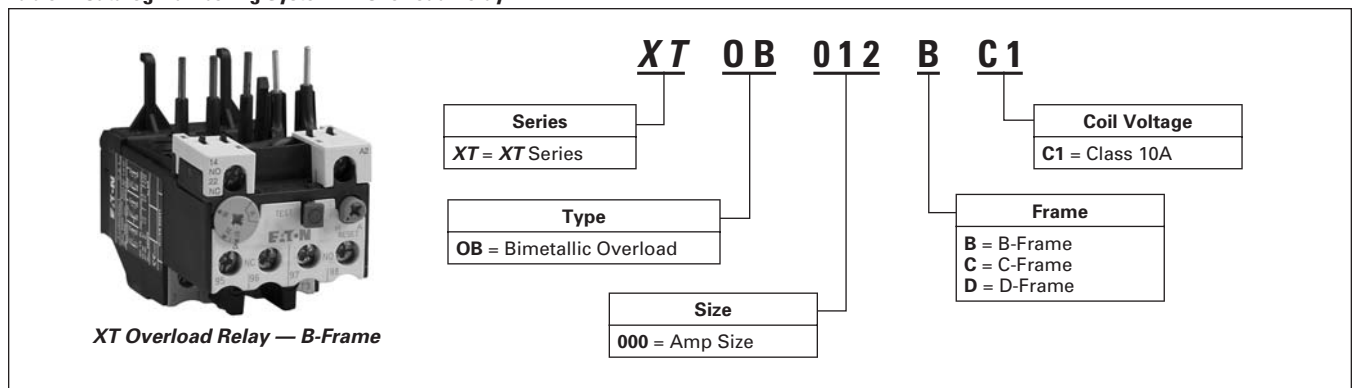

There are two types of overload relays, bimetallic and electronic. Bimetallic overloads have “heaters” that bend during an overcurrent situation to trigger a mechanism that changes the state of the auxiliary contacts. The contactor is wired in such a manner that it is taken offline if the overload trips.

Table 5. Overload Relay Selection, Frames B – D

	Overload Releases, I <sub>r</sub>	Contact Sequence	Contact Configuration	For Use with Contactor Amp Range	Short-Circuit Protection (A)			Catalog Number	
					Fuse		Maximum Circuit Breaker		CEC/NEC Fuse
					Type 1 Coordination, gG/gL	Type 2 Coordination, gG/gL			
<b>Frame B — Direct Mount</b>									
	0.1 – 0.16 0.16 – 0.24 0.24 – 0.4 0.4 – 0.6		1NO-1NC	7 – 15A	25	0.5	25	3	XTOBP16BC1
			1NO-1NC	7 – 15A	25	1	25	3	XTOBP24BC1
			1NO-1NC	7 – 15A	25	2	25	3	XTOBP40BC1
			1NO-1NC	7 – 15A	25	4	25	3	XTOBP60BC1
	0.6 – 1 1 – 1.6 1.6 – 2.4 2.4 – 4		1NO-1NC	7 – 15A	25	4	25	3	XTOB001BC1
			1NO-1NC	7 – 15A	25	6	25	6	XTOB1P6BC1
			1NO-1NC	7 – 15A	25	10	25	6	XTOB2P4BC1
			1NO-1NC	7 – 15A	25	16	25	15	XTOB004BC1
	4 – 6 6 – 10 9 – 12 12 – 16		1NO-1NC	7 – 15A	25	20	25	20	XTOB006BC1
			1NO-1NC	7 – 15A	50	25	25	35	XTOB010BC1
			1NO-1NC	9 – 15A	50	25	25	45	XTOB012BC1
			1NO-1NC	12 – 15A	50	25	30	45	XTOB016BC1
<b>Frame C — Direct Mount</b>									
	0.1 – 0.16 0.16 – 0.24 0.24 – 0.4 0.4 – 0.6		1NO-1NC	18 – 32A	25	0.5	25	3	XTOBP16CC1
			1NO-1NC	18 – 32A	25	1	25	3	XTOBP24CC1
			1NO-1NC	18 – 32A	25	2	25	3	XTOBP40CC1
			1NO-1NC	18 – 32A	25	4	25	3	XTOBP60CC1
	0.6 – 1 1 – 1.6 1.6 – 2.4 2.4 – 4		1NO-1NC	18 – 32A	25	4	25	3	XTOB001CC1
			1NO-1NC	18 – 32A	25	6	25	6	XTOB1P6CC1
			1NO-1NC	18 – 32A	25	10	25	6	XTOB2P4CC1
			1NO-1NC	18 – 32A	25	16	25	15	XTOB004CC1
	4 – 6 6 – 10 10 – 16 16 – 24 24 – 32		1NO-1NC	18 – 32A	25	20	25	20	XTOB006CC1
			1NO-1NC	18 – 32A	50	25	25	25	XTOB010CC1
			1NO-1NC	18 – 32A	63	35	30	25	XTOB016CC1
			1NO-1NC	18 – 32A	100	35	30	25	XTOB024CC1
1NO-1NC	25 – 32A	125	63	30	25	XTOB032CC1			
<b>Frame D — Direct Mount</b>									
	6 – 10 10 – 16 16 – 24		1NO-1NC	40 – 65A	50	25	25	25	XTOB010DC1
			1NO-1NC	40 – 65A	63	35	25	25	XTOB016DC1
			1NO-1NC	40 – 65A	63	50	30	25	XTOB024DC1
	24 – 40 40 – 57 50 – 65		1NO-1NC	40 – 65A	125	63	125	125	XTOB040DC1
			1NO-1NC	50 – 65A	160	80	150	150	XTOB057DC1
1NO-1NC	65A	160	100	150	200	XTOB065DC1			

**Practice:**

Select a C-frame **XT** contactor for a 10 hp, 460V motor with a 1NO auxiliary and a 120V AC Coil:

Select an overload relay for the contactor selected previously for a desired amp setting of 14 amps:

## Starters

A starter consists of a contactor assembled with an overload relay. Starters can be ordered as components and assembled in the

field or as a fully assembled device. Selecting a starter uses the same selection rules as for contactors and overload relays, but combined into a

single part number.

**Table 6** shows the catalog number system for **XT** starters.

**Table 6. Catalog Numbering System — Starters**

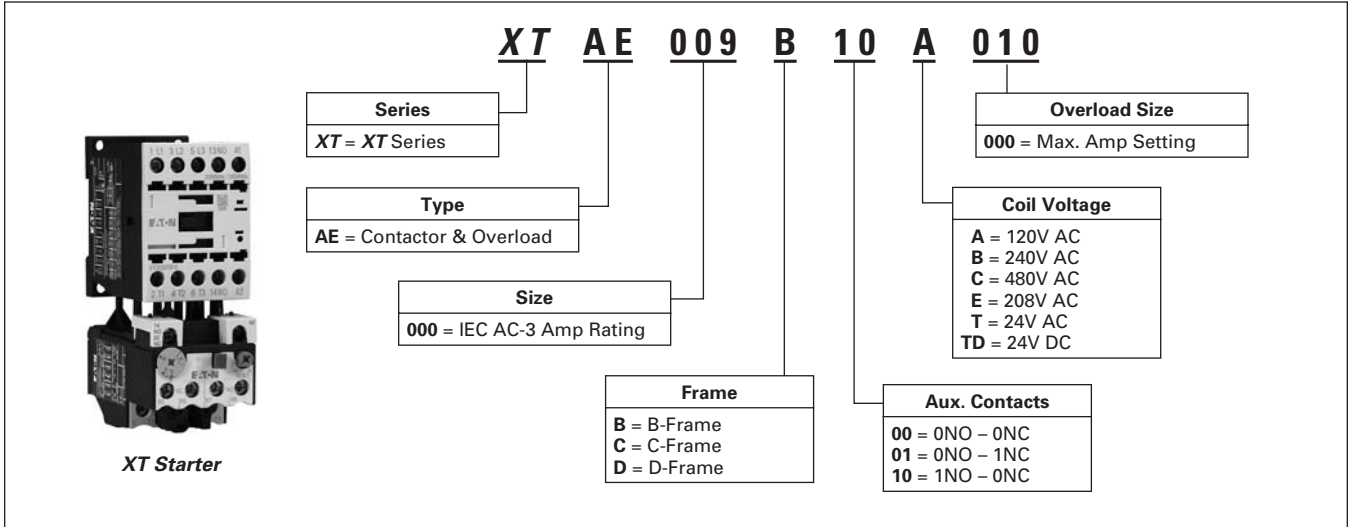

**Practice:**

Select an **XT** starter for a 20 hp, 460V motor (Full Load Current = 30A) with a 1NO auxiliary and a 120V AC Coil:  
 What is the frame size for this starter?

Break down catalog part number XTAE009B10A010 into its component part numbers:

Contactors:

Overload Relay:

Pull these components from your inventory and assemble them together to make the starter.

**Table 7. Full Voltage Non-reversing 3-Pole Starters with Bimetallic Overload**

I <sub>e</sub> (A)		Maximum kW Ratings AC-3					Maximum 3-Phase Motor Rating						Auxiliary Contacts	Catalog Number
AC-3	AC-1	3-Phase Motors 50 – 60 Hz					1-Phase hp Ratings		3-Phase hp Ratings					
		220/ 230V	380/ 400V	415V	660/ 690V	1000V	115V	230V	200V	230V	460V	575V		
<b>Frame B</b>														
7	20	2.2	3	4	3.5	—	1/4	1	1-1/2	2	3	5	1NO	XTAE007B10_ _
7	20	2.2	3	4	3.5	—	1/4	1	1-1/2	2	3	5	1NC	XTAE007B01_ _
9	20	2.5	4	5.5	4.5	—	1/2	1-1/2	3	3	5	7-1/2	1NO	XTAE009B10_ _
9	20	2.5	4	5.5	4.5	—	1/2	1-1/2	3	3	5	7-1/2	1NC	XTAE009B01_ _
12	20	3.5	5.5	7	6.5	—	1	2	3	3	10	10	1NO	XTAE012B10_ _
12	20	3.5	5.5	7	6.5	—	1	2	3	3	10	10	1NC	XTAE012B01_ _
15.5	20	4	7.5	8	7	—	1	3	5	5	10	10	1NO	XTAE015B10_ _
15.5	20	4	7.5	8	7	—	1	3	5	5	10	10	1NC	XTAE015B01_ _
<b>Frame C</b>														
18	35	5	7.5	10	11	—	2	3	5	5	10	15	1NO	XTAE018C10_ _
18	35	5	7.5	10	11	—	2	3	5	5	10	15	1NC	XTAE018C01_ _
25	40	7.5	11	14.5	14	—	2	5	7-1/2	7-1/2	15	20	1NO	XTAE025C10_ _
25	40	7.5	11	14.5	14	—	2	5	7-1/2	7-1/2	15	20	1NC	XTAE025C01_ _
32	40	10	15	18	17	—	3	5	10	10	20	25	1NO	XTAE032C10_ _
32	40	10	15	18	17	—	3	5	10	10	20	25	1NC	XTAE032C01_ _

**Table 8. XTOB and XTOT Overload Relay Suffix**

Motor Full Load Amperes	Suffix Code	For Use with Contactor Amp Range	Overload Relay Catalog Number
<b>Frame B</b>			
0.1 – 0.16	<b>P16</b>	7 – 15A	XTOBP16BC1
0.16 – 0.24	<b>P24</b>	7 – 15A	XTOBP24BC1
0.24 – 0.4	<b>P40</b>	7 – 15A	XTOBP40BC1
0.4 – 0.6	<b>P60</b>	7 – 15A	XTOBP60BC1
0.6 – 1	<b>001</b>	7 – 15A	XTOB001BC1
1 – 1.6	<b>1P6</b>	7 – 15A	XTOB1P6BC1
1.6 – 2.4	<b>2P4</b>	7 – 15A	XTOB2P4BC1
2.4 – 4	<b>004</b>	7 – 15A	XTOB004BC1
4 – 6	<b>006</b>	7 – 15A	XTOB006BC1
6 – 10	<b>010</b>	7 – 15A	XTOB010BC1
9 – 12	<b>012</b>	9 – 15A	XTOB012BC1
12 – 16	<b>016</b>	12 – 15A	XTOB016BC1
<b>Frame C</b>			
0.1 – 0.16	<b>P16</b>	18 – 32A	XTOBP16CC1
0.16 – 0.24	<b>P24</b>	18 – 32A	XTOBP24CC1
0.24 – 0.4	<b>P40</b>	18 – 32A	XTOBP40CC1
0.4 – 0.6	<b>P60</b>	18 – 32A	XTOBP60CC1
0.6 – 1	<b>001</b>	18 – 32A	XTOB001CC1
1 – 1.6	<b>1P6</b>	18 – 32A	XTOB1P6CC1
1.6 – 2.4	<b>2P4</b>	18 – 32A	XTOB2P4CC1
2.4 – 4	<b>004</b>	18 – 32A	XTOB004CC1
4 – 6	<b>006</b>	18 – 32A	XTOB006CC1
6 – 10	<b>010</b>	18 – 32A	XTOB010CC1
10 – 16	<b>016</b>	18 – 32A	XTOB016CC1
16 – 24	<b>024</b>	18 – 32A	XTOB024CC1
24 – 32	<b>032</b>	25 – 32A	XTOB032CC1

## Electronic Overload Relays

The **XT** line of IEC power control also has an electronic overload relay called the C396. Electronic overload relays serve the same purpose as bimetallic overload relays, but they use a circuit board to monitor current instead of a bimetal element. Electronic overloads have larger amp setting ranges than bimetals, generate less heat, and they also have excellent phase loss and phase imbalance protection.

**Tables 9 – 12** show the part numbering structure for the electronic overload relay, the electronic overload starter, the selection table for the direct mount electronic overload (**XT** Frames B – D) and the selection table for stand-alone electronic overloads. As is true for the bimetal overloads, the overload is selected based on the desired amp setting and matching contactor frame size.

**Table 9. Catalog Numbering System — Overload Relay (Electronic)**

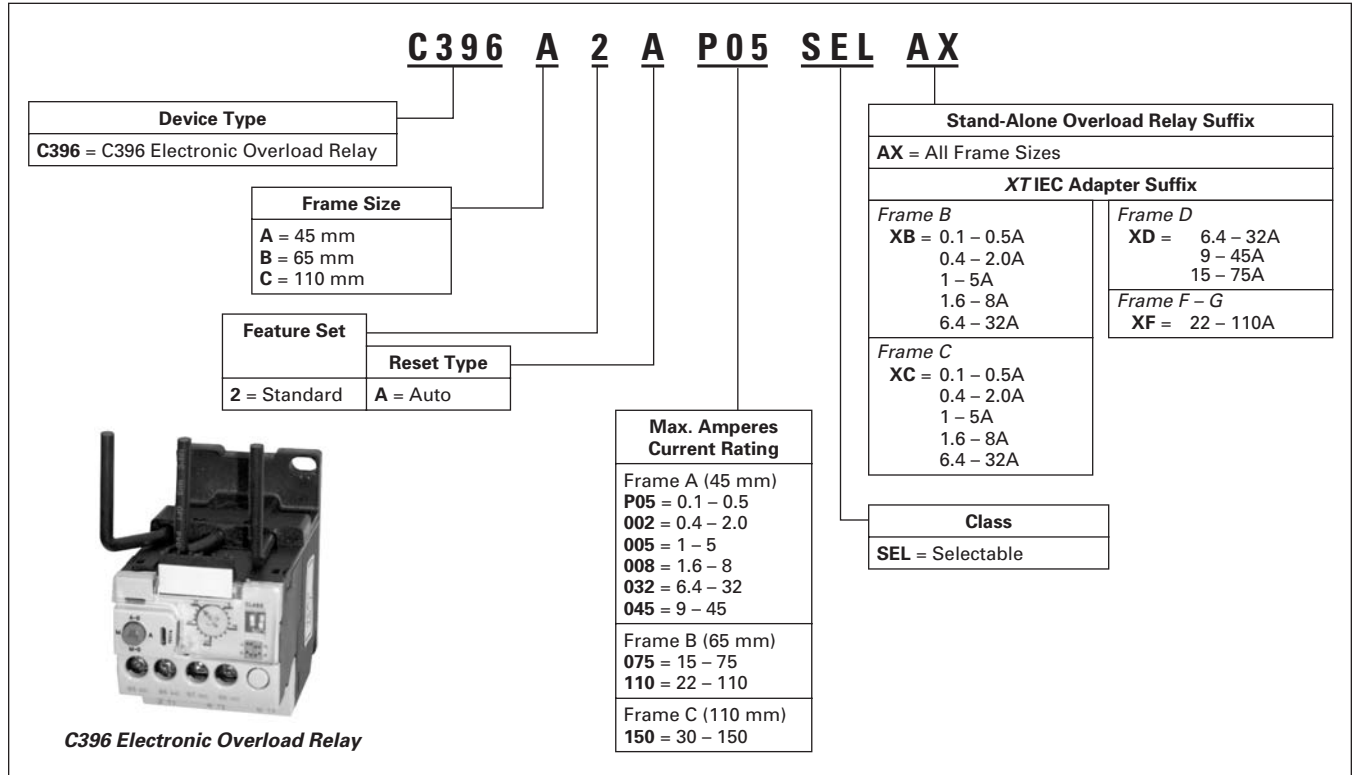

Table 10. Catalog Numbering System — Starter (with Electronic Overload)

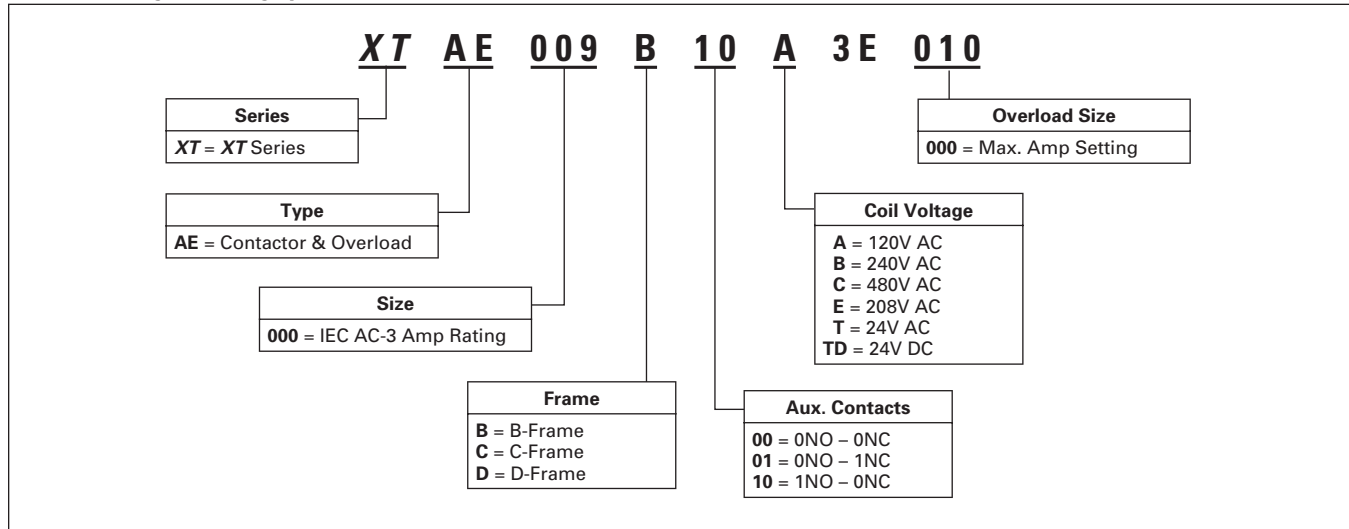

Table 11. Electronic Overload Relay Selection (for XT Frames B – C)

FLA Range (Amps)	Suffix	XT IEC Contactor Frame Size / Width	Catalog Number
	Standard Class 5/10/20/30		
<b>45 mm Overload Frame Size</b>			
0.1 – 0.5	3EP05	B / 45 mm	C396A2AP05SELXB
0.4 – 2.0	3E002	B / 45 mm	C396A2A002SELXB
1 – 5	3E005	B / 45 mm	C396A2A005SELXB
1.6 – 8	3E008	B / 45 mm	C396A2A008SELXB
6.4 – 32	3E032	B / 45 mm	C396A2A032SELXB
0.1 – 0.5	3EP05	C / 45 mm	C396A2AP05SELXC
0.4 – 2.0	3E002	C / 45 mm	C396A2A002SELXC
1 – 5	3E005	C / 45 mm	C396A2A005SELXC
1.6 – 8	3E008	C / 45 mm	C396A2A008SELXC
6.4 – 32	3E032	C / 45 mm	C396A2A032SELXC

Table 12. Electronic Overload Relay Selection (Stand-Alone)

FLA Range (Amps)	Standard Class 5/10/20/30
	Catalog Number
<b>45 mm Overload Frame Size</b>	
0.1 – 0.5	C396A2AP05SELAX
0.4 – 2.0	C396A2A002SELAX
1 – 5	C396A2A005SELAX
1.6 – 8	C396A2A008SELAX
6.4 – 32	C396A2A032SELAX
9 – 45	C396A2A045SELAX
<b>65 mm Overload Frame Size</b>	
15 – 75	C396B2A075SELAX
22 – 110	C396B2A110SELAX

**Practice:**

Select an electronic overload for a stand-alone application for a motor with a full load current of 2 amps:

---

Select an **XT** starter (with an electronic overload) for a 10 hp (460V) motor with a full load current of 12 amps:

---

List the components of the starter from the previous question:

Contactors:

---

Overload Relay:



---



## Reversing Contactors

Reversing contactors enable motors to operate in a forward and reverse operation. They consist of two contactors that are interlocked together such that both contactors cannot be operated at the same time. Reversing contactors can be interlocked both mechanically (by using the mechanical interlock) and electrically (by using NC auxiliary contacts wired with the opposing coil from the opposing contactor). **Table 13** lists the mechanical interlocks by frame size.

**Table 13. Mechanical Interlock Selection for XT Frame B – G**

	For Use with...	Pkg. Qty.	Catalog Number
	XTCE007B – XTCE015B, XTCE020B	5	XTCEXMLB
	XTCE018C – XTCE032C	1	XTCEXMLC
	XTCE040D – XTCE065D	1	XTCEXMLD
	XTAE080F – XTCE150G	1	XTCEXMLG

**Practice:**

Select the mechanical interlock for the B-frame contactor:

Pull (2) B-frame contactors and the B-frame mechanical interlock from your inventory and use the instruction pub to assemble a reversing contactor.

The **XT** line also has wiring link kits that make wiring a reversing contactor much faster to install. The following table lists the reversing link kits for the **XT**.

**IMPORTANT NOTE:** The reversing link kit for the B-frame contactors includes an electrical interlock wiring link for contactors that have a NC aux contact built in to the contactor. If the contactors you have chosen have a NO aux contact instead of a NC, do not use the electrical interlock wiring link, as this will cause both contactors to attempt to pull in and will result in chattering.

**Table 14** shows the reversing link kits for **XT**.

**Table 14. Mechanical Interlock Selection for XT Frame B – G**

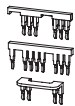
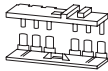
	For Use with...	Pkg. Qty.	Catalog Number
	XTCE007B – XTCE015B	1	XTCEXRLB
	XTCE018C – XTCE032C	1	XTCEXRLC
	XTCE040D – XTCE065D	1	XTCEXRLD
	XTCE080F – XTCE150G	1	XTCEXRLG

**Practice:**

Select the reversing link kit for the B-frame contactor:

Using the reversing contactor built in the previous practice section, install the reversing B-frame reversing link kit using the instruction pub to finish assembly of the reversing contactor.

## Contactor Accessories

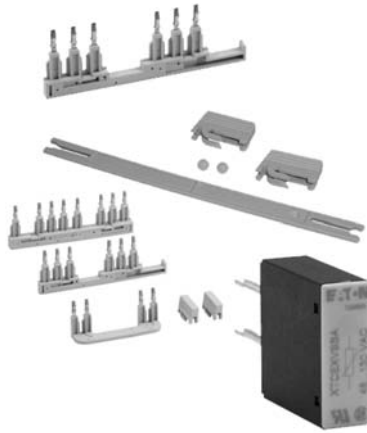

The **XT** line has a variety of accessories from auxiliary contacts to timers to plug-in surge suppressors. The most commonly used accessory is the auxiliary contact. An auxiliary contact is a device that assembles to the contactor either on the front (face) or the side of the contactor, and contains contacts that change state in concert with the power pole contacts inside the contactor. Auxiliary contacts can be used to turn on a pilot light, signal a PLC that the contactor is closed, or can be used for a variety of other types of control activities. The most common use for an auxiliary contact is to enable continued operation of a contactor without having an operator to continually push a start button. Auxiliary contacts come in a variety of combinations of normally open (NO) and normally closed (NC) contacts. This means that

the contact in a NO aux contact is open when the contactor is not in operation. When the contact in the contactor closes, the NO auxiliary contact also closes. A NC auxiliary would remain closed unless the contacts in the contactor close.

As is true with overload relays, accessories should be selected to match the contactor frame size. In some cases, there are other specifications, such as coil voltage, that must match the corresponding specification of the contactor. These accessory attributes can be found in the selection tables for the contactor accessories in the catalog.

**Table 15** shows the general numbering scheme for just a few of the contactor accessories, but all accessories generally follow this same system.

**Table 15. Catalog Numbering System — Contactor Accessories**

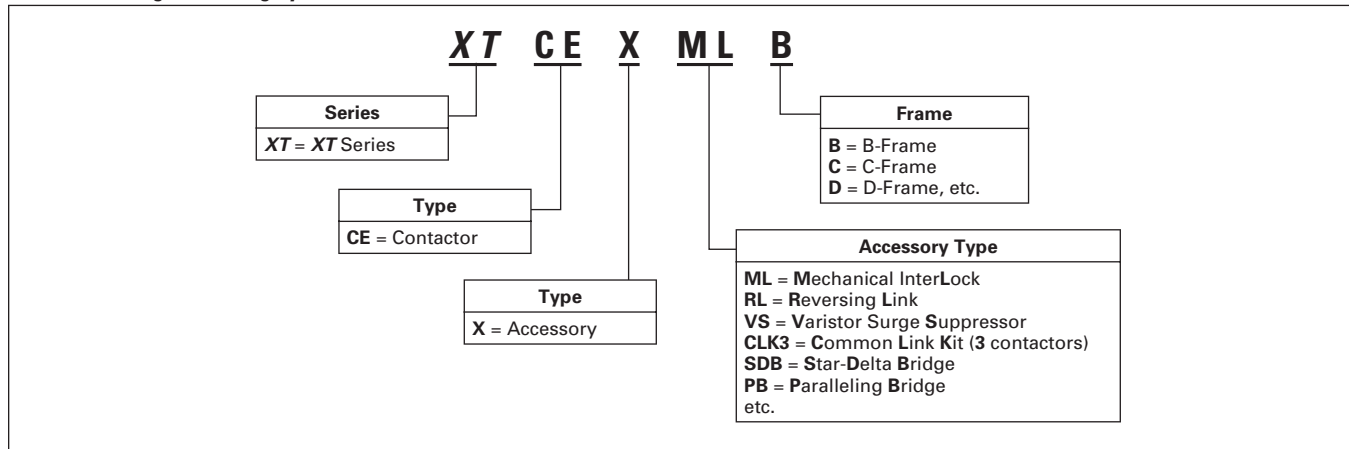

## Contactor Coils



*Contactor Coils*

The **XT** line of contactors includes coils with a variety of voltages for replacement or exchange purposes. Many distributors stock contactors with one common coil voltage and a variety of contactor coils with other coil voltages. This way, they can easily switch out coils if they get a request for a contactor of a different coil voltage. This helps minimize the total cost of inventory.

Contactor coils are selected based on the frame size and the desired coil voltage. **Table 16** lists the numbering scheme for the **XT** contactor coils. Coils are only available for C-frame contactors and larger.

**Table 16. Catalog Numbering System — Contactor Coils**

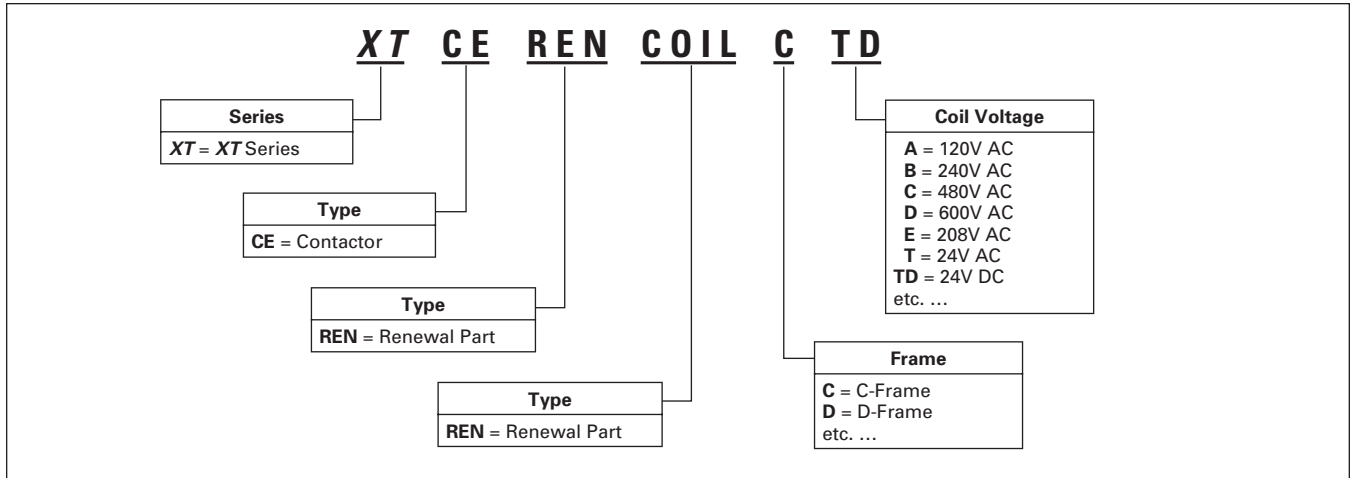

All contactor frames can have replaceable coils except the B-frame. For about the same price as the coil, the entire B-frame contactor can be replaced.

**Practice:**

Select a replacement coil for a C-frame contactor that is rated for 480V AC:

Pull the coil part selected in the previous question and a C-frame contactor from your inventory and practice switching out the coils. Use the instructions to assist you with the coil exchange.



### Combination Style Starters

Combination style starters consist of a manual motor protector assembled with a contactor. This relatively new type of starter is growing in popularity because it can be used in place of a breaker/fuse block, contactor and overload relay. Combination style starters install more quickly and require less space than the traditional scheme.

There are two types of combination style controllers: one with a line side adapter and one without a line side adapter. The line side adapter increases the voltage creepage clearance on the line side of the combination style starters. The line side adapter is required for UL508 Type F combinations.

Combination style starters are selected using the same rules as manual motor protectors. Tables 19 and 20 show the numbering scheme and a portion of the selection table for the combination style controllers.

Table 19. Catalog Numbering System — Combination Style

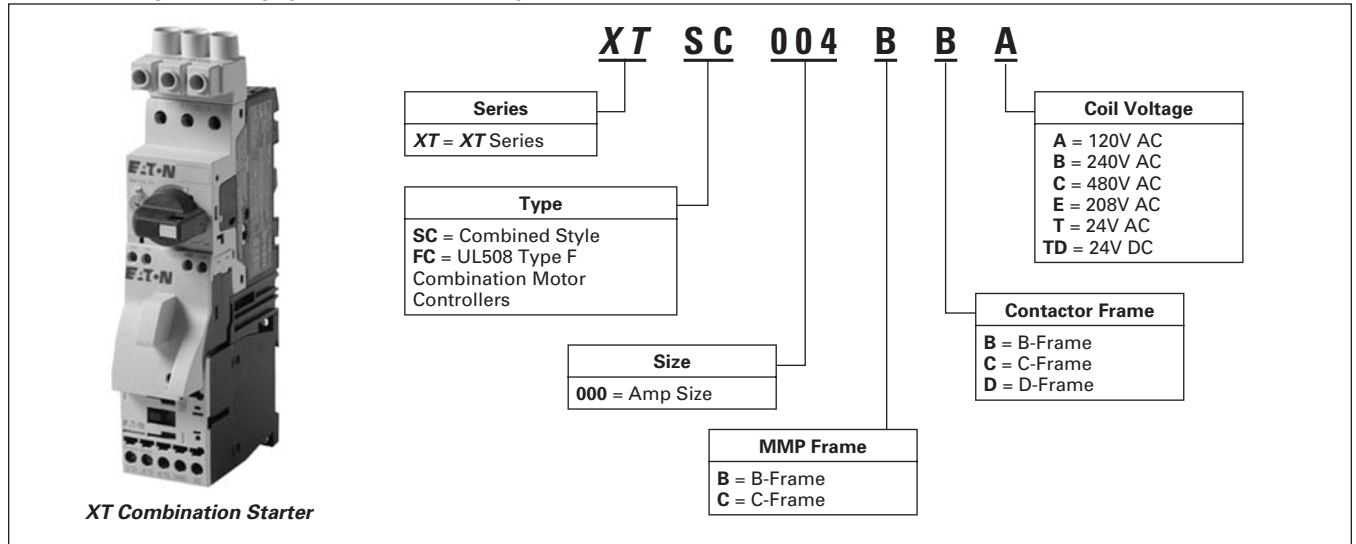

Table 20. Factory Assembled Motor Protective Device with Thermal and Magnetic Trip + Contactor

FLA Adjustment Range / Overload Release — I <sub>r</sub> (Amps)	Short-Circuit Release — I <sub>rm</sub> (Amps)	Maximum Motor Ratings — P ①								Assembled Manual Motor Controller
		Maximum Motor kW Rating AC-3 — P (kW)				Maximum hp Rating — P (hp)				
		Three-Phase				Three-Phase				
		220 – 240V	380 – 415V	500V	660 – 690V	200V	240V	480V	600V	Non-reversing Catalog Number
0.1 – 0.16	3.2	—	—	—	0.06	—	—	1/2	1/2	XTSCP16BB_
0.16 – 0.25	3.5	—	0.06	0.06	0.12	—	—	1/2	1/2	XTSCP25BB_
0.25 – 0.4	5.6	0.06	0.09	0.12	0.18	—	—	1/2	1/2	XTSCP40BB_
0.4 – 0.63	8.82	0.09	0.18	0.25	0.25	—	—	1/2	1/2	XTSCP63BB_
0.63 – 1	14	0.12	0.25	0.37	0.55	—	—	1/2	1/2	XTSC001BB_
1 – 1.6	22.4	0.25	0.55	0.75	1.1	—	—	3/4	1	XTSC1P6BB_
1.6 – 2.5	35	0.37	0.75	1.1	1.5	1/2	1/2	1	1-1/2	XTSC2P5BB_
2.5 – 4	56	0.75	1.5	2.2	3	1	1	2	3	XTSC004BB_
4 – 6.3	88.2	1.1	2.2	3	4	1-1/2	1-1/2	3	5	XTSC6P3BB_
6.3 – 10	140	2.2	4	4	7.5	3	3	7-1/2	10	XTSC010BB_
8 – 12	168	3	5.5	5.5	11	3	3	7-1/2	10	XTSC012BB_
10 – 16	224	4	7.5	9	12.5	3	3	10	10	XTSC016BB_

Frame B MMP + Frame B Contactor

FLA Adjustment Range / Overload Release — I <sub>r</sub> (Amps)	Short-Circuit Release — I <sub>rm</sub> (Amps)	220 – 240V	380 – 415V	500V	660 – 690V	200V	240V	480V	600V	Assembled Manual Motor Controller
0.1 – 0.16	3.2	—	—	—	0.06	—	—	1/2	1/2	XTSCP16BB_
0.16 – 0.25	3.5	—	0.06	0.06	0.12	—	—	1/2	1/2	XTSCP25BB_
0.25 – 0.4	5.6	0.06	0.09	0.12	0.18	—	—	1/2	1/2	XTSCP40BB_
0.4 – 0.63	8.82	0.09	0.18	0.25	0.25	—	—	1/2	1/2	XTSCP63BB_
0.63 – 1	14	0.12	0.25	0.37	0.55	—	—	1/2	1/2	XTSC001BB_
1 – 1.6	22.4	0.25	0.55	0.75	1.1	—	—	3/4	1	XTSC1P6BB_
1.6 – 2.5	35	0.37	0.75	1.1	1.5	1/2	1/2	1	1-1/2	XTSC2P5BB_
2.5 – 4	56	0.75	1.5	2.2	3	1	1	2	3	XTSC004BB_
4 – 6.3	88.2	1.1	2.2	3	4	1-1/2	1-1/2	3	5	XTSC6P3BB_
6.3 – 10	140	2.2	4	4	7.5	3	3	7-1/2	10	XTSC010BB_
8 – 12	168	3	5.5	5.5	11	3	3	7-1/2	10	XTSC012BB_
10 – 16	224	4	7.5	9	12.5	3	3	10	10	XTSC016BB_

① Select Manual Motor Protectors by full load amperes. Maximum Motor Ratings (kW, hp) are for reference only. For additional voltages not listed, see Table 34-227 on Page 34-183 of the Control Catalog.

**Practice:**

Using the above table, select a combination style controller for a 7 hp motor (480V) with a 1.25 service factor, a FLA of 9 amps and a coil voltage of 120V AC:

Combination style controllers can be either purchased as an assembled device, or can be built from stocked components. **Table 21** lists the components used in the assembly of the combination style starters for the B-frame.

**Table 21. Factory Assembled Motor Protective Device with Thermal and Magnetic Trip + Contactor**

Assembled Manual Motor Controller	FLA Adjustment Range / Overload Release — I <sub>r</sub> (Amps)	Component Catalog Numbers			
		Manual Motor Protector	Combination Connection Kit	Contactor	Manual Motor Protector Auxiliary Contact
<b>Non-reversing</b>					
<b>XTSC Frame B MMP + Frame B Contactor</b>					
XTSCP16BB_	0.1 – 0.16	XTPRP16BC1	XTPAXTPCB	XTCE007B10_	XTPAXFA11
XTSCP25BB_	0.16 – 0.25	XTPRP25BC1	XTPAXTPCB	XTCE007B10_	XTPAXFA11
XTSCP40BB_	0.25 – 0.4	XTPRP40BC1	XTPAXTPCB	XTCE007B10_	XTPAXFA11
XTSCP63BB_	0.4 – 0.63	XTPRP63BC1	XTPAXTPCB	XTCE007B10_	XTPAXFA11
XTSC001BB_	0.63 – 1	XTPR001BC1	XTPAXTPCB	XTCE007B10_	XTPAXFA11
XTSC1P6BB_	1 – 1.6	XTPR1P6BC1	XTPAXTPCB	XTCE007B10_	XTPAXFA11
XTSC2P5BB_	1.6 – 2.5	XTPR2P5BC1	XTPAXTPCB	XTCE007B10_	XTPAXFA11
XTSC004BB_	2.5 – 4	XTPR004BC1	XTPAXTPCB	XTCE007B10_	XTPAXFA11
XTSC6P3BB_	4 – 6.3	XTPR6P3BC1	XTPAXTPCB	XTCE007B10_	XTPAXFA11
XTSC010BB_	6.3 – 10	XTPR010BC1	XTPAXTPCB	XTCE009B10_	XTPAXFA11
XTSC012BB_	8 – 12	XTPR012BC1	XTPAXTPCB	XTCE012B10_	XTPAXFA11
XTSC016BB_	10 – 16	XTPR016BC1	XTPAXTPCB	XTCE015B10_	XTPAXFA11

**Practice:**

Using the above table, list the components of the starter selected in the previous section:

\_\_\_\_\_

Pull these components from stock and use the instructions to build the assembled starter.



Eaton Corporation  
Electrical Group  
1000 Cherrington Parkway  
Moon Township, PA 15108  
United States  
877-ETN CARE (877-386-2273)  
Eaton.com



**Cutler-Hammer**

© 2008 Eaton Corporation  
All Rights Reserved  
Printed in USA  
Publication No. TR03407001E/CPG  
March 2008