

Surface
SMT
Mount

2mm HEADER TMM SERIES

SPECIFICATIONS

For complete specifications and recommended PCB layouts see www.samtec.com?TMM

Insulator Material: Black Liquid Crystal Polymer

Terminal Material: Phosphor Bronze

Plating: Sn or Au over 50µ" (1,27µm) Ni

Operating Temp Range: -55°C to +105°C with Tin; -55°C to +125°C with Gold

Voltage Rating: 500 VAC mated with SQW
450 VAC mated with SQT

RoHS Compliant: Yes

CURRENT RATING		
AMBIENT TEMP	Mated with	
	SQT	CLT
20°C	5.5A	3.7A
40°C	5A	3.3A
60°C	4A	2.9A
80°C	3A	2.4A

Processing:

Max Processing Temp: 230°C for 60 seconds, or 260°C for 20 seconds 3x

Lead-Free Solderable: Yes

SMT Lead Coplanarity: (0,15mm) .006" max

Mates with: CLT, SQT, SQW, ESQT, TLE, SMM, MMS, TCSD

ALSO AVAILABLE

Through-Hole

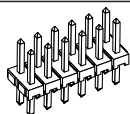

2mm Shunt

Specify **2SN-BK-G** for 2mm shunt with Gold plating.

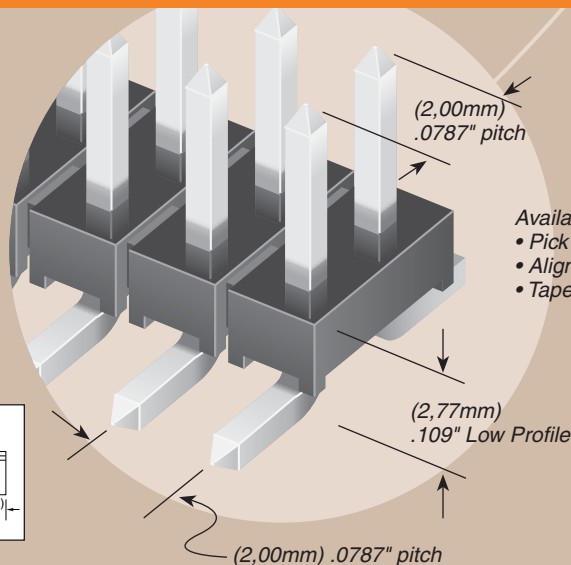
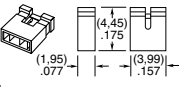

Available with optional

- Pick & Place Pads
- Alignment pins
- Tape & reel packaging

TMM - 1 NO. PINS PER ROW - LEAD STYLE - PLATING OPTION - ROW OPTION - SM - OTHER OPTION

02 thru 40

Specify LEAD STYLE from chart below.

-L
= 10µ" (0,25µm) Gold on contact area, Matte Tin on tail

-G
= 20µ" (0,51µm) Gold on contact area, Gold flash on tail

-T
= Matte Tin

-S
= 30µ" (0,76µm) Gold on contact area, Matte Tin on tail

-S
= Single Row

-D
= Double Row

-“XXX”
= Polarized Position (Specify position of omitted pin)

-A
= Alignment Pin (Metal or plastic at Samtec's discretion) (5 positions minimum) (-D only)

-M
= Metal Pick & Place Pad (4 positions minimum) (-T plating not available) (-D only)

-P
= Pick & Place Pad (3 positions minimum)

-TR
= Tape & Reel Pkg. (3 positions minimum)

LEAD STYLE	A	MATES WITH
-01	(3,20) .126	SQT, SQW, ESQT, TLE, SMM, MMS, TCSD
-04	(1,91) .075	
-05	(1,65) .065	CLT
-06	(4,27) .168	CLT-BE

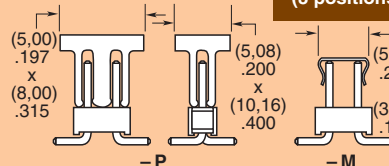
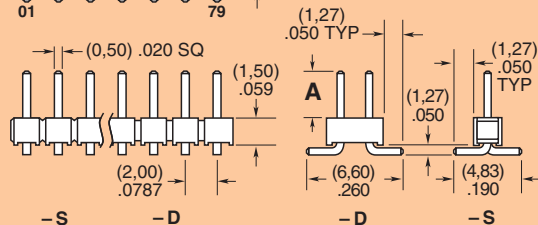
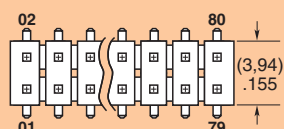
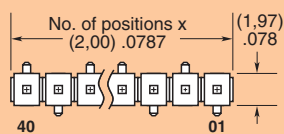

Note: Some lengths, styles and options are non-standard, non-returnable.

Due to technical progress, all designs, specifications and components are subject to change without notice.

WWW.SAMTEC.COM