

# Rolling Code Set Up Procedures

The rolling code receiver can operate on 24v AC/DC or 12v AC/DC

**Note:** the voltage must be selected as shown above before powering up as over voltage will damage the system.

**Procedure for receiver to learn a rolling code transmitter:**

1. Ensure jumper is correctly set on receiver to set it up for learning mode.
2. Press the reset button on the receiver board; this should illuminate the red LED. Hold the button until the LED turns off (approx. 8 seconds).
3. Press the reset button once again; this should illuminate the red LED again to show that the receiver is in learning mode.
4. Before the LED turns off press the Ch 1 button on the transmitter, this should cause the relay to click and also illuminate the red LED momentarily. The receiver should have now learned the code for Ch1, and Ch 2 is automatically learned.
5. Before the LED definitively turns off, press sequentially Ch 1 of all other transmitters if applicable, again Ch2 of these transmitters will be automatically learned. After each stored code the relay will click.
6. When the last code is stored, wait for the red LED to turn off. This means that learning mode is completed.

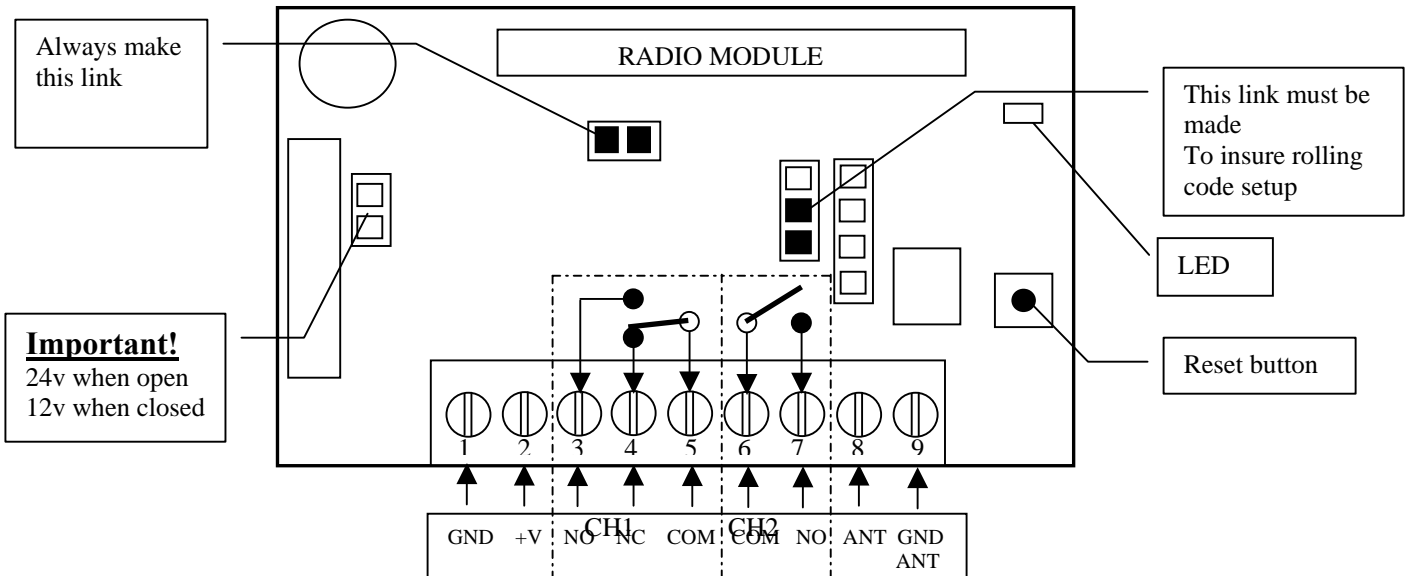
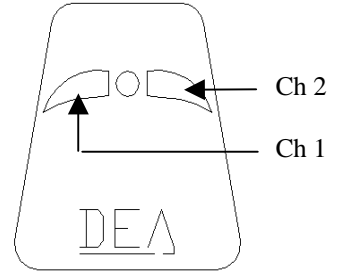

### Voltage Selection

The maximum voltage that can be supplied to this unit is 24V AC/DC. Do not exceed this voltage.

The voltage must be selected on each individual relay PCB using the jumper links shown on the bottom right of the relay PCB. Ensure that each PCB is set to the correct voltage before applying power.

### Relay Contacts

All relay contacts are normally open volt free contacts. The maximum current switched by the relay is 1A, Maximum voltage at the contacts 240V AC