

STRAIGHT PLUG CLAMP TYPE

CABLE 5/50 S+D

R141.009.000

Series : **BNC**

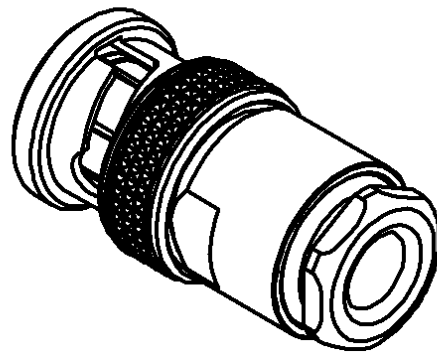
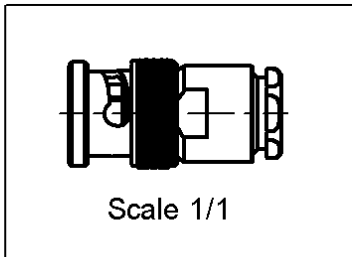
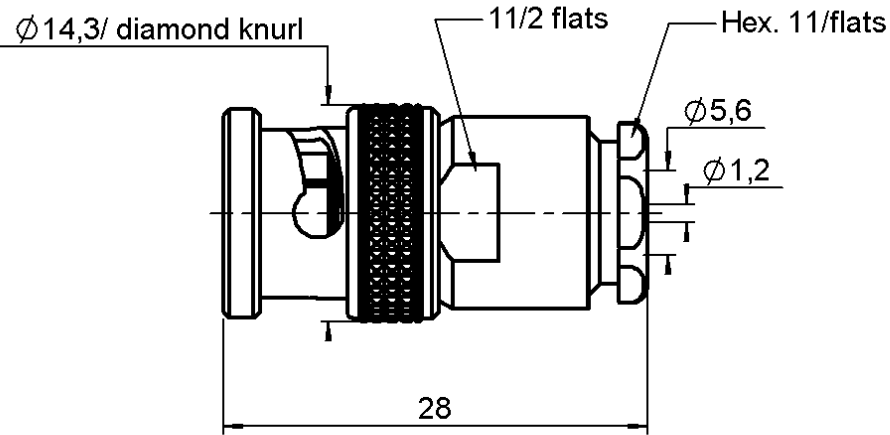

All dimensions are in mm.



COMPONENTS	MATERIALS	PLATINGS (μm)
BODY	BRASS	NICKEL 2
CENTER CONTACT	BRASS	GOLD 0.5 OVER NICKEL 2
OUTER CONTACT	-	-
INSULATOR	PTFE	-
GASKET	SILICONE RUBBER	-
OTHERS PARTS	BRASS	NICKEL 2
-	-	-
-	-	-

Issue : 0309 B

In the effort to improve our products, we reserve the right to make changes judged to be necessary.



STRAIGHT PLUG CLAMP TYPE

R141.009.000

CABLE 5/50 S+D

Series : **BNC**

PACKAGING

Standard	Unit	Other
100	'W' option	Contact us

SPECIFICATION

QAE 06-02A - -

ELECTRICAL CHARACTERISTICS

Impedance		50	Ω
Frequency		0-4	GHz
VSWR	1.2 +	0.000	x F(GHz) Maxi
Insertion loss		0.115	\sqrt{F} (GHz) dB Maxi
RF leakage	- (57	- F(GHz)) dB Maxi
Voltage rating		500	Veff Maxi
Dielectric withstanding voltage		1500	Veff mini
Insulation resistance		5000	M Ω mini

CABLE ASSEMBLY

Stripping	a	b	c	d	e	f
mm	4.50	8.50	0.00	0.00	2.50	0.00

Assembly instruction : **Clamp 02**

Recommended cable(s)

RG 223
RG 58
KX 15
RG 142 FTX
RG 141
RG 400
RG 142
KX 23

Cable retention

- pull off **180** N mini
- torque **NA** N.cm

MECHANICAL CHARACTERISTICS

Center contact retention			
Axial force – Mating end	NA	N	N mini
Axial force – Opposite end	NA	N	N mini
Torque	NA	N.cm	N.cm mini

TOOLING

Part Number	Description	Hexagon
.	.	.

Recommended torque			
Mating	NA	N.cm	
Panel nut	NA	N.cm	
Clamp nut	450	N.cm	
A/F clamp nut	11.000	mm	

Mating life	500	Cycles	mini
Weight	17.000	g	

OTHERS CHARACTERISTICS

-

ENVIRONMENTAL

Operating temperature	-65/+165	$^{\circ}$ C
Hermetic seal	NA	Atm.cm3/s
Panel leakage	NA	

Issue : **0309 B**

In the effort to improve our products, we reserve the right to make changes judged to be necessary.

