

A

## Part front panels

B

### Part front panel with handle

- **TFP OG** part front panel without handle with handle perforation
- **TFP AG** part front panel with anodised aluminium handle and fixing material
- **TFP KG** part front panel with plastic-handle, anodised insert strip and fixing material
- **TFP KG ... only 3-8 and 10-14**
- part front panel clear anodised
- **HP** = width unit = 5,08; **U** = height unit = 44,45

C

D

E

F

G

H

I

K

L

M

N

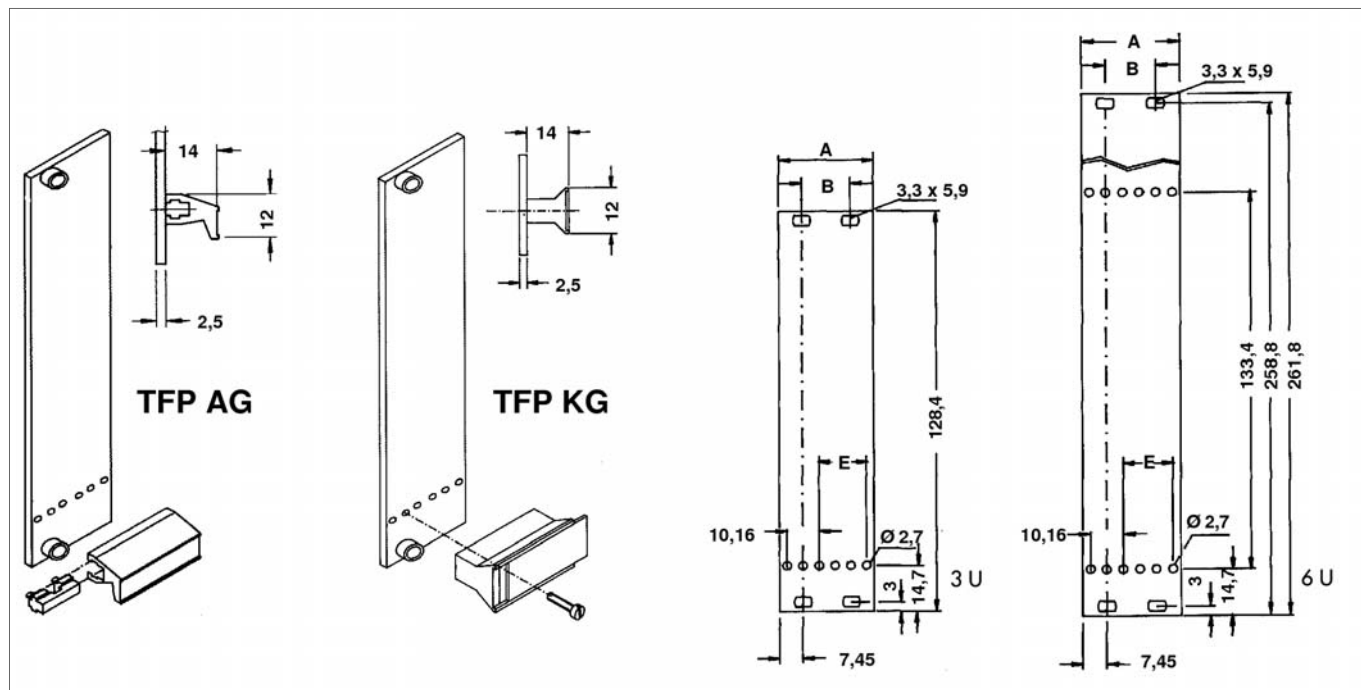

art. no.	HP	dim. [mm]		
		A	B	E
TFP ... 3 ...	3	14.9	–	–
TFP ... 4 ...	4	20.0	–	5.08
TFP ... 5 ...	5	25.1	–	10.16
TFP ... 6 ...	6	30.2	–	15.24
TFP ... 7 ...	7	35.3	–	20.32
TFP ... 8 ...	8	40.3	–	25.40
TFP ... 9 ...	9	45.4	–	30.50
TFP ... 10 ...	10	50.5	35.6	35.60
TFP ... 12 ...	12	60.7	45.7	45.70
TFP ... 14 ...	14	70.8	55.9	55.90
TFP ... 16 ...	16	81.0	66.0	66.00
TFP ... 18 ...	18	91.1	76.2	76.20
TFP ... 20 ...	20	101.3	86.4	86.40
TFP ... 21 ...	21	106.4	91.4	91.40
TFP ... 24 ...	24	121.6	106.7	106.70
TFP ... 28 ...	28	141.9	127.0	127.00

please indicate:

... part front panel (optional)  
**OG**=without handle with handle  
 perforation

**AG**=with anodised aluminium handle  
 and fixing material

**KG**=with plastic-handle, anodised insert  
 strip and fixing material

... metal nipples (optional)  
**MN 2**=press-in

... height unit  
**3**=3 U  
**6**=6 U

## N 59

Part front panels with handle → N 59  
 Part front panels with PCB holder → N 60 – 61  
 Part front panels with SMD-brackets → N 63  
 Insert modules → N 41 – 52

Handles for part front panels → N 67  
 Extractor for part front panels → N 66  
 Part front panels for EMC-applicat. → N 39 – 40  
 Profiles for 19" front panels → N 78 – 79