

# Chip Arrays

Fair-Rite offers an effective cost and real estate reduction by our line of chip arrays. Four chip beads, packaged in a 1206 (3216) size, for suppression of conducted EMI where size is at a premium. Chip arrays are 100% tested for impedance and dc resistance. They are available in standard and high signal speeds.

- Chip arrays have plated contacts, 100% tin over a nickel undercoating.
- Chip arrays are supplied taped and reeled, if required bulk packed arrays can be supplied. For particulars on the taped and reeled parts see the Part Number System below.
- Chip arrays are controlled for impedance. The impedance values listed are typical values. The nominal impedance with a +/- 25% tolerance is specified for the + marked 100 MHz frequency. Chip arrays are measured for impedance on the HP 4291A and fixture HP 16192A.
- The arrays can accommodate both reflow and wave soldering technologies. See page 28 for the recommended soldering profile for lead-free chip components.
- Suggested land patterns are in accordance to the IPC-7351.
- Recommended storage and operating temperature range is -55 °C to 125 °C.
- Performance curves for the chip arrays, with and without dc bias, are on the Fair-Rite Products CD-ROM.
- "Chip Bead Kit" (part number 0199000018) contains the high speed 220 ohm 4 line chip array. See page 67.

## Part Number Sytem: Example 2512066007Y0A4

25	1206	600	7	Y	0	A4
Chip Suppression Component	Package Size	Impedance Code	Packaging Code	Material Code	Current Code	Array 4 Lines
		600 = 60 Ω	6 = Bulk Packed 7 = T&R	Y = Std Signal Speed Z = GHz Speed	0 < 1A	

## Fair-Rite Products Corp.

Phone: (888) FAIR RITE / (845) 895-2055 • FAX: (888) FERRITE / (845) 895-2629  
(888) 324-7748 (888) 337 -7483

PO Box J, One Commercial Row, Wallkill, NY 12589-0288

• www.fair-rite.com  
• E-Mail: ferrites@fair-rite.com

# Chip Arrays

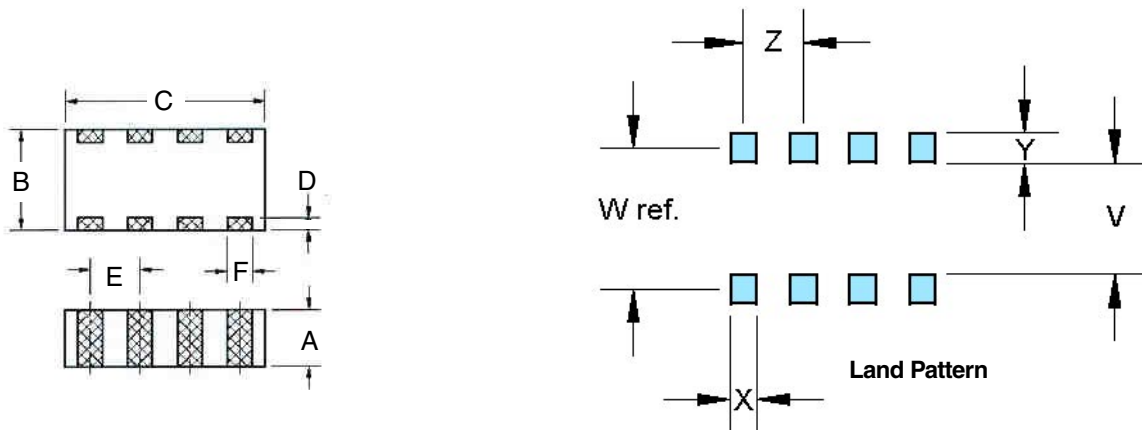

Pkg. Size	Dimensions	A	B	C	D	E	F	Wgt (g)
1206	mm	0.8±0.2	1.6±0.2	3.2±0.2	0.3±0.2	0.8±0.1	0.4±0.15	0.03
	inches	.031	.063	.126	.011	.031	.016	

Land Pattern						Reel Information		
	V	W ref.	X	Y	Z	Tape Width mm	Pitch mm	Parts per 7" reel
mm	0.7	1.3	0.5	0.6	0.8	8	4	3000
inches	.028	.051	.020	.024	.032			

Part Number	Speed	Z (Ω) 50 MHz	Z (Ω) ±25% 100 MHz	Z (Ω) 500 MHz	Z (Ω) 1000 MHz	Max DCR (Ω)	Max Current (mA)
2512066007Y0A4	Standard	48	60	77	75	0.25	200
2512061217Y0A4	Standard	95	120	150	118	0.3	150
2512063017Y0A4	Standard	225	300	280	160	0.3	150
2512066017Y0A4	Standard	460	600	400	205	0.5	100
2512061027Y0A4	Standard	770	1000	400	200	0.7	50
2512061217Z0A4	High Speed	68	120	215	205	0.3	200
2512062217Z0A4	High Speed	95	220	360	205	0.45	150