

Dial Test Indicators

SERIES 513 — Horizontal Type

DIAL TEST INDICATORS



513-404E



513-464E



513-414E



513-401E



513-405E



513-424E
513-414E
513-466E



513-404E
513-464E



513-415E



513-426E



513-405E
513-465E



513-425E



513-401E



513-409

FEATURES

- Performs easy and accurate measurement of narrow or recessed areas, plus inside and outside diameters that dial indicators cannot access.
- No-clutch structure for automatic reversal of measuring direction.
- Resistant to water and dust thanks to the one-piece bezel and "crystal" design with O-ring.
- The glare-free flat crystal face has a scratch-resistant coating.
- High-sensitivity and quick-response because of jeweled bearings.
- A carbide contact point is provided as standard.

Dimensions

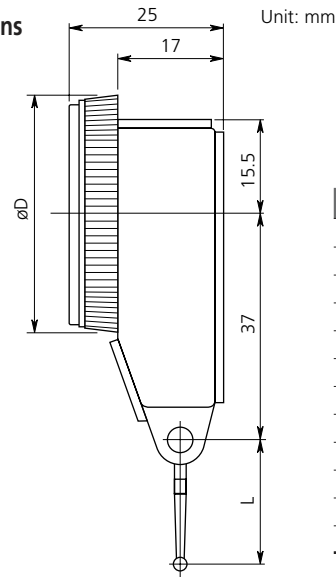

Order No.	D	L
513-424E	39	22.3
513-414E	39	36.8
513-466E	28	22.3
513-404E	39	20.9
513-464E	28	20.9
513-415E	39	44.5
513-426E	39	22.3
513-405E	39	14.7
513-465E	28	14.7
513-425E	39	14.7
513-401E	39	12.8
513-409	39	14.7



High Precision Type



Doubled Scale Spacing



Long Contact Point



Revolution Counter



Compact Type



Dustproof



Jeweled



Anti-Magnetic



Water resistance