

OPERATION INSTRUCTIONS

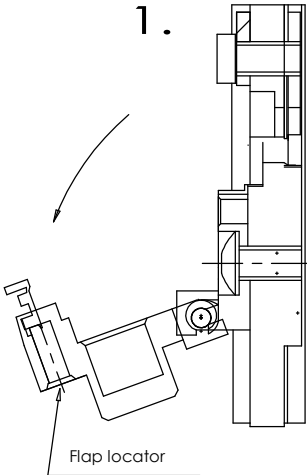

1. Open flap locator and insert contact up to stop.

2. Close flap locator.

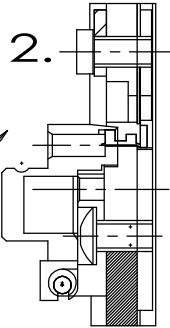

3. Close handtool until first ratchet.

4. Insert wire up to stop.

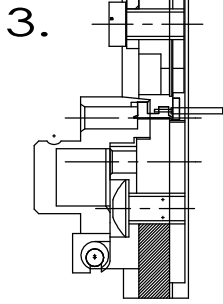
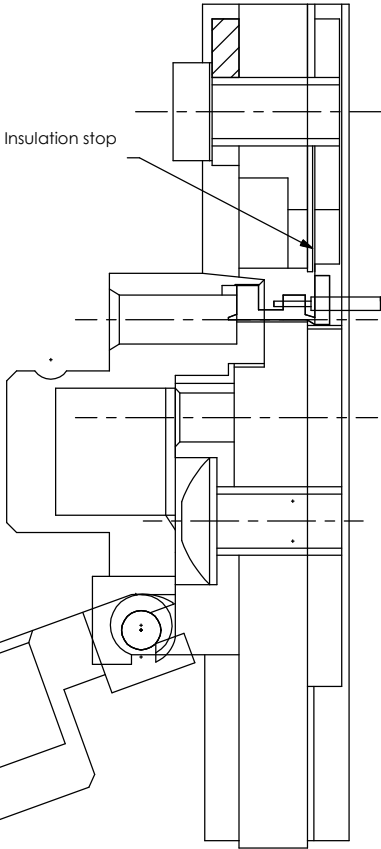

5. Close handtool until the ratchet releases.

6. Open flap locator and carefully remove the wire.

DWG: JUKCT-024-01-00

JST

Hand crimping tool

Type: WC-JWPF

Features

Parallel action operation

Ratchet release

Easy readjustment of load

Contact locator with insulation-stop

Precisely ground profiles

Ergonomic soft grips colour: green

Fully recyclable

Applicable terminal:

() WPT-001T-0.25

() WPR-001T-0.25

Cross section range:

Profile 1: 26 AWG

Profile 2: 22 AWG

Profile 3: 24 AWG

Crimp height specification

26 AWG - 0.80mm

24 AWG - 0.82mm

22 AWG - 0.92mm

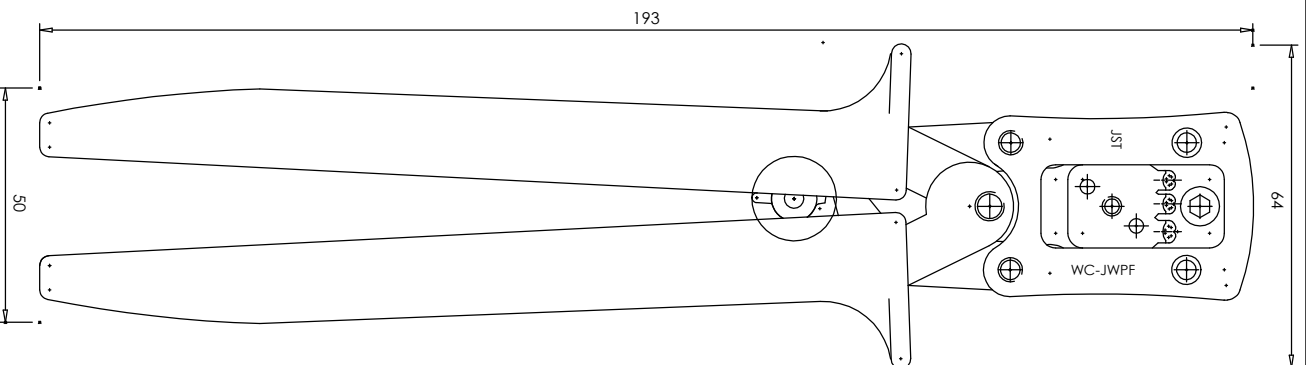

Operating instructions see overleaf