

LOC	DIST	REVISIONS					
		P	LTR	DESCRIPTION	DATE	DWN	APVD
1	-	AW6	ECR-09-013317		25/JUN/09	PKS	MW
		AW5	ECO-07-012970		09 MAY 07	H.Y.	-

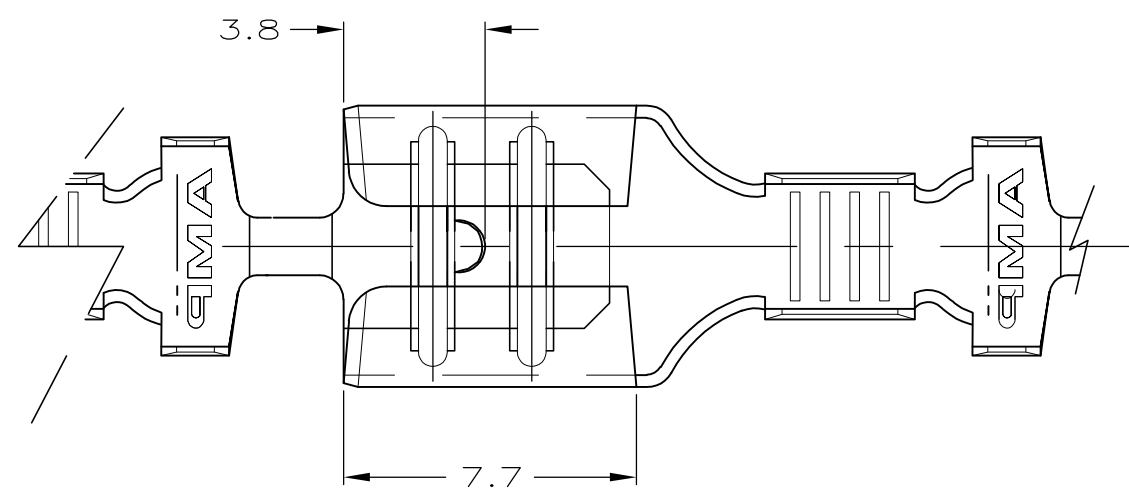

1) STATO DI FORNITURA - SCALA 1:1
 (SUPPLY CONDITION - SCALE 1:1)

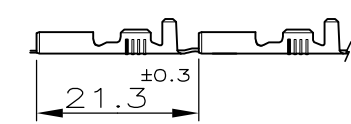

SENDO DI USCITA DEL TERMINALE DALLA BOBINA
 (DIRECTION OFF TOP OF REEL)

△ SPECIFICA DI PRODOTTO 108-20019
 (PRODUCT SPEC. 108-20019)
 SPECIFICA DI APPLICAZIONE 114-20023
 (APPLICATION SPEC. 114-20023).

3) PER LE VERSIONI IN PEZZI SCIOLTI VEDERE DISEGNO 160506
 (FOR LOOSE PIECE VERSION SEE DRAWING 160506).

- △ 4 NON IN PRODUZIONE (NOT YET RELEASE FOR PRODUCTION)
- △ 5 ADATTO PER ALTA FORZA DI ESTRAZIONE (SUITABLE FOR HIGHER EXTRACTION FORCE)
- △ 6 ADATTO PER TAB SPESSO 0.63mm. (FOR 0.63mm TAB THK.)

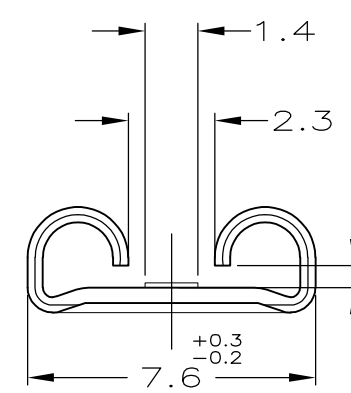

FOR 0.8mm & 0.63mm TAB THK.

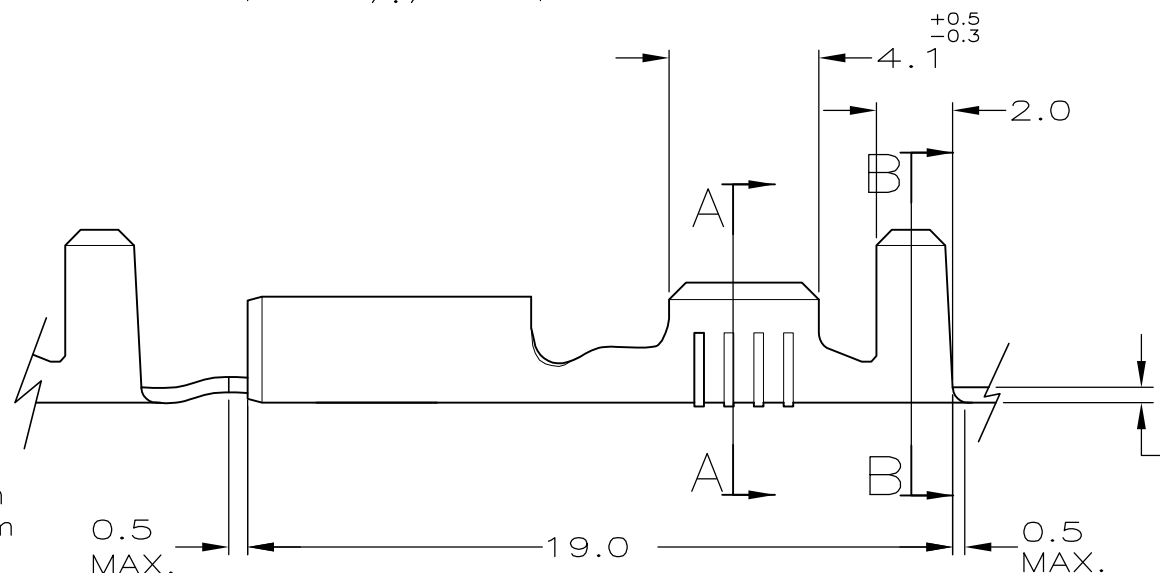

SEZIONE A-A
 (SECTION A-A)

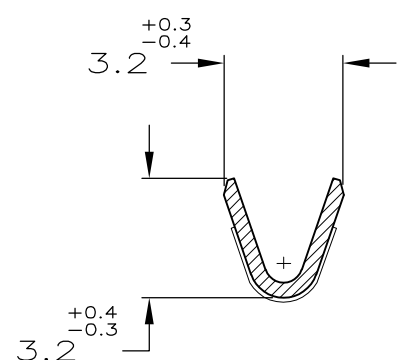

SEZIONE B-B
 (SECTION B-B)

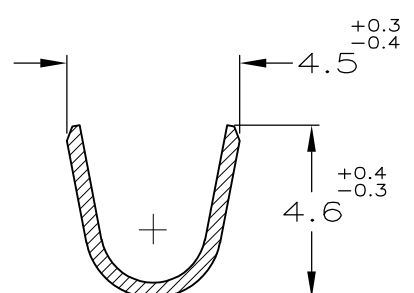

△ 6 / △ 4	STAGNATO (TINPLATED)	OTTONE (BRASS)	7-160432-3	AY
△ 5 / △ 4	STAGNATO (TINPLATED)	OTTONE (BRASS)	7-160432-2	AW
△ 5 / △ 4	NUDO (UNPLATED)	OTTONE (BRASS)	7-160432-1	AW
	STAGNATO (TINPLATED)	OTTONE (BRASS)	7-160432-0	AU
	NUDO (UNPLATED)	BRONZO FOSF.(PH. BRONZE)	6-160432-4	AU
	PRE NICHELATO (PRE NICKEL PLATED)	ACCIAIO (STEEL)	6-160432-3	AU
	STAGNATO (TINPLATED)	BRONZO FOSF.(PH. BRONZE)	6-160432-0	AU
	ARGENTATO (SILVER PLATED)	OTTONE (BRASS)	5-160432-7	AW
	STAGNATO (TINPLATED)	OTTONE (BRASS)	5-160432-4	AU
	NUDO (UNPLATED)	OTTONE (BRASS)	5-160432-3	AW
NOTE (NOTES)	FINITURA (FINISH)	MATERIALE (MATERIAL)	NUMERO (AMP P/N)	REV

THIS DRAWING IS A CONTROLLED DOCUMENT.

DWN H.YAALI 14 MAY 99	Tyco Electronics ITALIA S.p.A COLLEGNO (TORINO)
CHK C.TARTARI 14 MAY 99	
APVD -	NAME
PRODUCT SPEC -	FASTON® Connector .250 SERIES REC. CONTACT
APPLICATION SPEC △ 2	RESTRICTED TO -
MATERIAL / MATERIALE SEE TABLE (VEDI LA TABELLA)	FINISH / FINITURA SEE TABLE (VEDI LA TABELLA)
WEIGHT -	SIZE A3 CAGE CODE 00779 DRAWING NO C-160432
CUSTOMER DRAWING	SCALE - SHEET 1 OF 1 REV AW6