

HM62256 Series

392 534

Maintenance only

32768-word × 8-bit High Speed CMOS Static RAM

Features

- High speed: Fast access time 85/100/120/150 ns (max)
- Low power standby and low power operation
 - Standby: 200 μ W (typ)/ 10 μ W (typ) (L-/L-SL-version)
 - Operation: 40 mW (typ) ($f = 1$ MHz)
- Single 5 V supply
- Completely static RAM: No clock or timing strobe required
- Equal access and cycle time
- Common data input and output, three-state output
- Directly TTL compatible—all inputs and outputs
- Battery back up operation capability (L-/L-SL-version)

Ordering Information

Type No.	Access time	Package
HM62256P-8	85 ns	600-mil 28-pin plastic DIP
HM62256P-10	100 ns	
HM62256P-12	120 ns	
HM62256P-15	150 ns	
HM62256LP-8	85 ns	
HM62256LP-10	100 ns	
HM62256LP-12	120 ns	
HM62256LP-15	150 ns	
HM62256LP-10SL	100 ns	
HM62256LP-12SL	120 ns	
HM62256LP-15SL	150 ns	

Type No.	Access time	Package
HM62256FP-8T	85 ns	28-pin plastic SOP
HM62256FP-10T	100 ns	
HM62256FP-12T	120 ns	
HM62256FP-15T	150 ns	
HM62256LFP-8T	85 ns	
HM62256LFP-10T	100 ns	
HM62256LFP-12T	120 ns	
HM62256LFP-15T	150 ns	
HM62256LFP-10SLT	100 ns	
HM62256LFP-12SLT	120 ns	
HM62256LFP-15SLT	150 ns	

Pin Arrangement

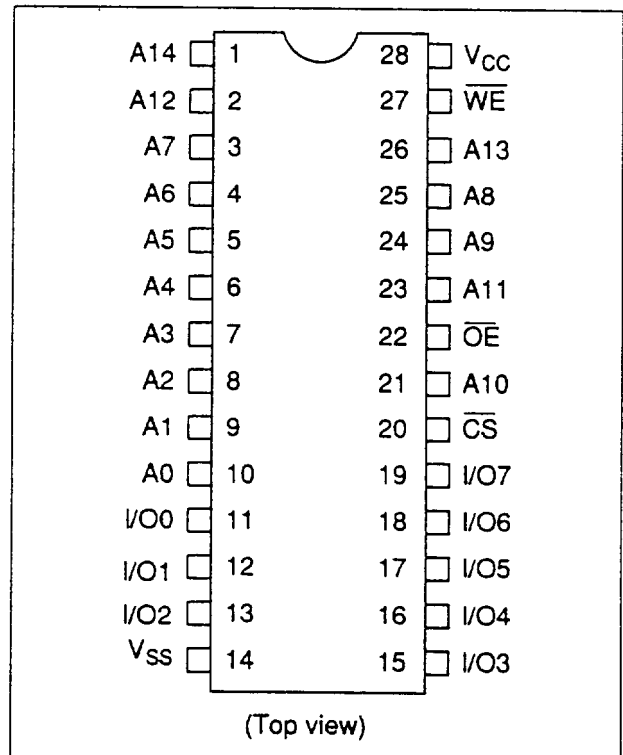

Note: This device is not available for new application.

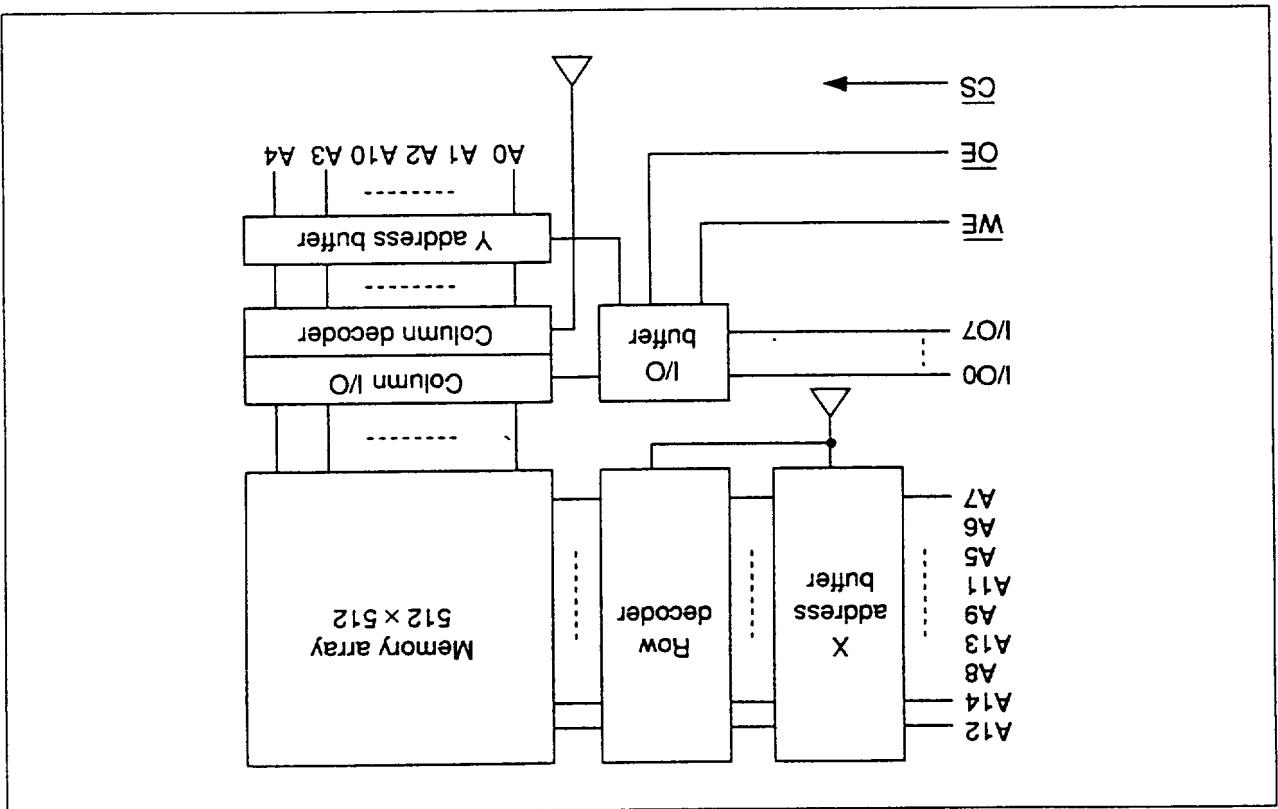

Truth Table

CS	OE	WE	Mode	V _{CC} current	I/O pin	Reference cycle
H	x	x	Not selected	I _{SB} , I _{SB1}	High Z	—
L	L	H	Read	I _{CC}	Dout	Read cycle No. 1-3
L	L	L	Write	I _{CC}	Din	Write cycle No. 1
L	L	L	Write	I _{CC}	Din	Write cycle No. 2

Note: x means H or L

Absolute Maximum Ratings

Parameter	Symbol	Rating	Unit
Voltage on any pin relative to V_{SS}	V_T	-0.5* to +7.0	V
Power dissipation	P_T	1.0	W
Operating temperature	T_{opr}	0 to +70	°C
Storage temperature	T_{stg}	-55 to +125	°C
Temperature under bias	T_{bias}	-10 to +85	°C

Note: -3.0 V min for pulse width ≤ 50 ns

Recommended DC Operating Conditions ($T_a = 0$ to +70°C)

Parameter	Symbol	Min	Typ	Max	Unit
Supply voltage	V_{CC}	4.5	5.0	5.5	V
	V_{SS}	0	0	0	V
Input voltage	V_{IH}	2.2	—	6.0	V
	V_{IL}	-0.5*	—	0.8	V

Note: -3.0 V min for pulse width ≤ 50 ns

DC Characteristics ($V_{CC} = 5$ V $\pm 10\%$, $V_{SS} = 0$ V, $T_a = 0$ to +70°C)

Parameter	Symbol	Min	Typ *1	Max	Unit	Test condition	
Input leakage current	$ I_{LI} $	—	—	2	μ A	$V_{IN} = V_{SS}$ to V_{CC}	
Output leakage current	$ I_{LO} $	—	—	2	μ A	$\overline{CS} = V_{IH}$ or $\overline{OE} = V_{IH}$ or $\overline{WE} = V_{IL}$ $V_{IO} = V_{SS}$ to V_{CC}	
Operating power supply current	I_{CC}	—	8	15	mA	$\overline{CS} = V_{IL}$, $I_{IO} = 0$ mA	
Average operating power supply current	HM62256-8	I_{CC1}	—	50	70	mA	Min. cycle, duty = 100%, $\overline{CS} = V_{IL}$, $I_{IO} = 0$ mA
	HM62256-10		—	40	70	mA	
	HM62256-12		—	35	70	mA	
	HM62256-15		—	33	70	mA	
		I_{CC2}	—	8	15	mA	$\overline{CS} = V_{IL}$, $V_{IH} = V_{CC}$, $V_{IL} = 0$ V, $I_{IO} = 0$ mA, $f = 1$ MHz

HM62256 Series

DC Characteristics ($V_{CC} = 5\text{ V} \pm 10\%$, $V_{SS} = 0\text{ V}$, $T_a = 0\text{ to } +70^\circ\text{C}$) (cont)

Parameter	Symbol	Min	Typ *1	Max	Unit	Test condition
Standby power supply current	I_{SB}	—	0.5	3	mA	$\overline{CS} = V_{IH}$
	I_{SB1}	—	0.04	2	mA	$\overline{CS} \geq V_{CC} - 0.2\text{V}$, $0\text{V} \leq V_{IN}$
	—	—	2^{*2}	100^{*2}	μA	
	—	—	2^{*3}	50^{*3}		
Output voltage	V_{OL}	—	—	0.4	V	$I_{OL} = 2.1\text{ mA}$
	V_{OH}	2.4	—	—	V	$I_{OH} = -1.0\text{ mA}$

- Notes: 1. Typical values are at $V_{CC} = 5.0\text{ V}$, $T_a = 25^\circ\text{C}$ and specified loading.
 2. These characteristics are guaranteed only for L-version.
 3. These characteristics are guaranteed only for L-SL version.

Capacitance ($T_a = 25^\circ\text{C}$, $f = 1\text{ MHz}$)

Parameter	Symbol	Typ	Max	Unit	Test Condition
Input capacitance	C_{IN}	—	6	pF	$V_{IN} = 0\text{ V}$
Input/output capacitance	$C_{I/O}$	—	8	pF	$V_{I/O} = 0\text{ V}$

Note: These parameters are sampled and not 100% tested.

AC Characteristics ($V_{CC} = 5\text{ V} \pm 10\%$, $T_a = 0\text{ to } +70^\circ\text{C}$ unless otherwise noted)

AC Test Conditions:

- Input pulse levels: 0.8 V to 2.4 V
- Input and output timing reference levels: 1.5 V
- Input rise and fall times: 5 ns
- Output load: 1TTL gate and $C_L = 100\text{ pF}$ (including scope and jig)

Read Cycle

Parameter	Symbol	HM62256-8		HM62256-10		HM62256-12		HM62256-15		Unit
		Min	Max	Min	Max	Min	Max	Min	Max	
Read cycle time	t_{RC}	85	—	100	—	120	—	150	—	ns
Address access time	t_{AA}	—	85	—	100	—	120	—	150	ns
Chip select access time	t_{ACS}	—	85	—	100	—	120	—	150	ns
Output enable to output valid	t_{OE}	—	45	—	50	—	60	—	70	ns
Output hold from address change	t_{OH}	5	—	10	—	10	—	10	—	ns
Chip selection to output in low Z	t_{CLZ}	10	—	10	—	10	—	10	—	ns
Output enable to output in low Z	t_{OLZ}	5	—	5	—	5	—	5	—	ns
Chip deselection to output in high Z	t_{CHZ}	0	30	0	35	0	40	0	50	ns
Output disable to output in high Z	t_{OHZ}	0	30	0	35	0	40	0	50	ns

Read Timing Waveform (1)

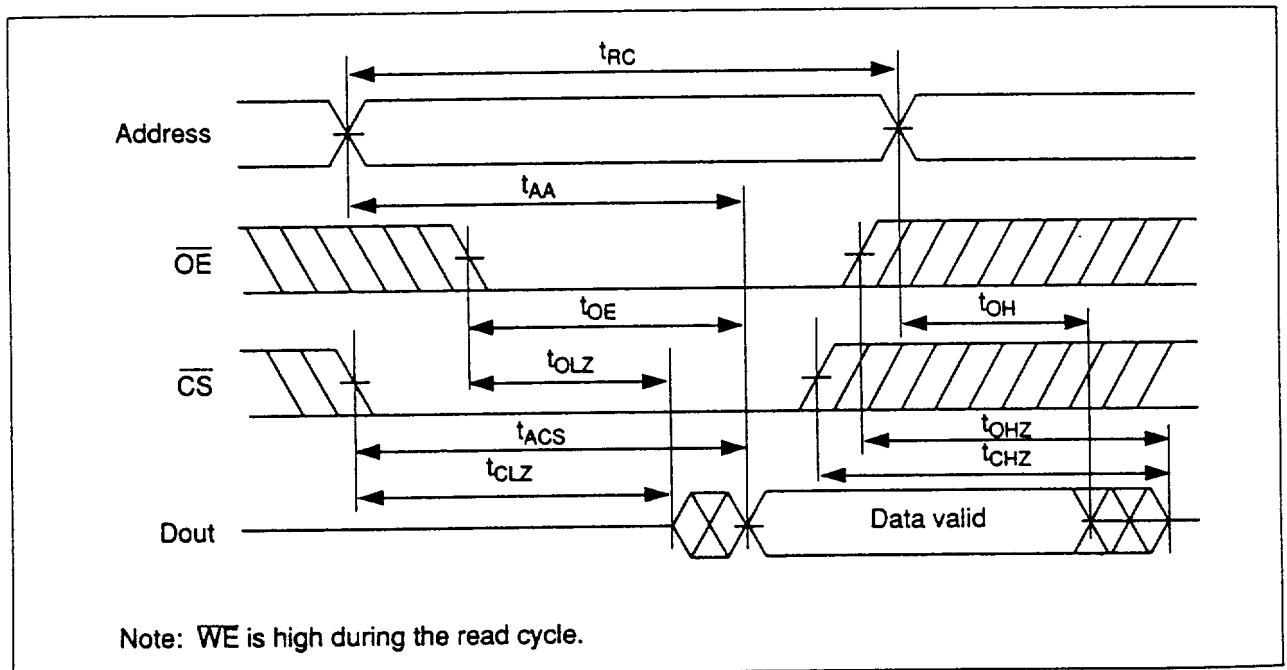

Read Timing Waveform (2)

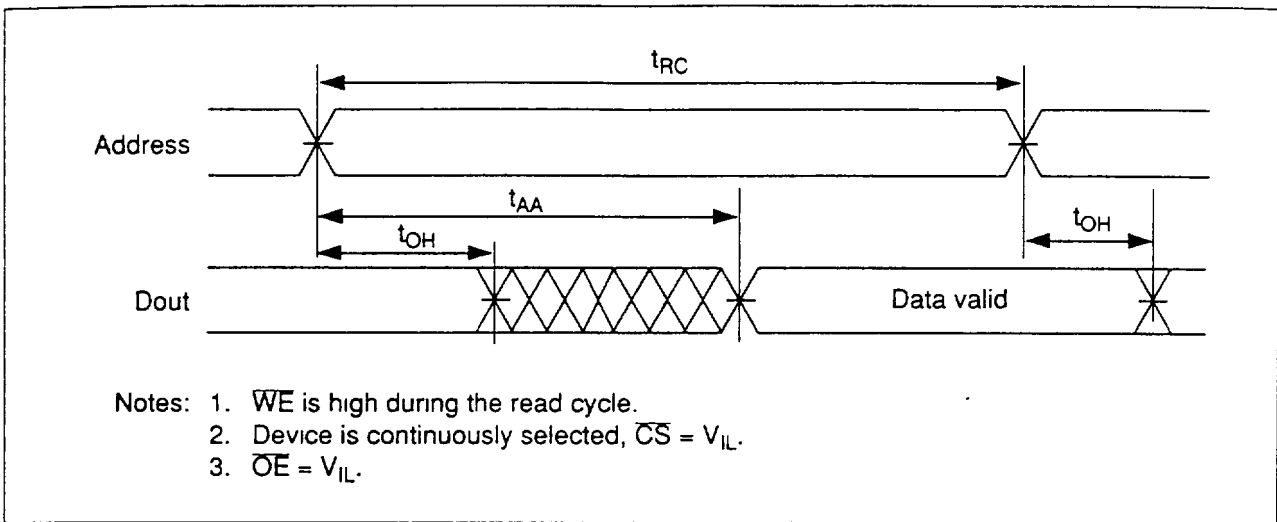

Read Timing Waveform (3)

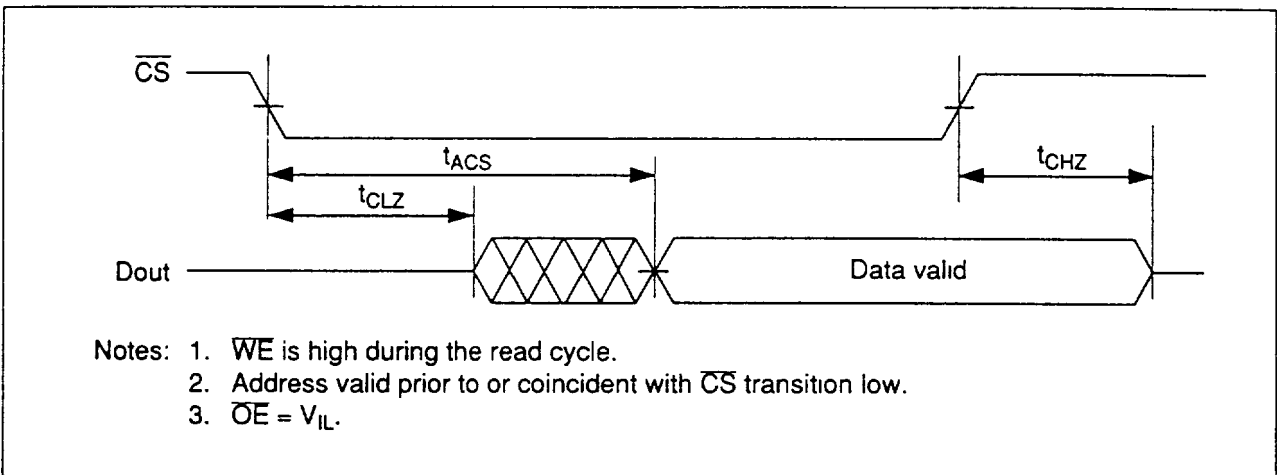

HM62256 Series

Write Timing Waveform (2) (\overline{OE} Fixed Low)

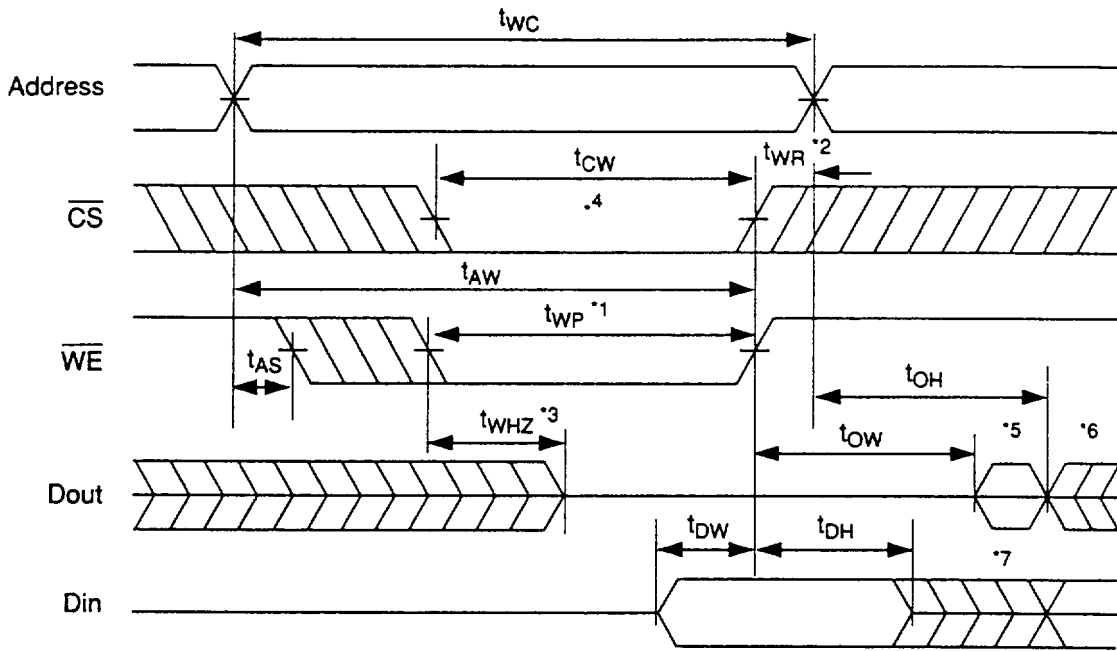

- Notes:
1. A write occurs during the overlap (t_{WP}) of a low \overline{CS} and a low \overline{WE} .
 2. t_{WR} is measured from the earlier of \overline{CS} or \overline{WE} going high to the end of write cycle.
 3. During this period, I/O pins are in the output state. The input signals out of phase must not be applied.
 4. If the \overline{CS} low transition occurs simultaneously with the \overline{WE} low transition or after the \overline{WE} low transition, outputs remain in a high impedance state.
 5. Dout is in the same phase of written data of this write cycle.
 6. Dout is the read data of next address.
 7. If \overline{CS} is low during this period, I/O pins are in the output state. Out of phase input signals must not be applied to I/O pins.

Low V_{CC} Data Retention Characteristics ($T_a = 0$ to $+70^\circ\text{C}$)

These characteristics are guaranteed only for L- and L-SL version.

Parameter	Symbol	Test Conditions	Min	Typ	Max	Unit
V_{CC} for data retention	V_{DR}	$\overline{CS} \geq V_{CC} - 0.2 \text{ V}$	2.0	—	—	V
Data retention current	I_{CCDR}	$V_{CC} = 3.0 \text{ V}$, $\overline{CS} \geq 2.8 \text{ V}$ $0 \text{ V} \leq V_{IN}$	—	—	$50 \cdot 2$ $10 \cdot 3$	μA
Chip deselect to data retention time	t_{CDR}	See retention waveform	0	—	—	ns
Operation recovery time	t_R	See retention waveform	$t_{RC} \cdot 1$	—	—	ns

- Notes: 1. t_{RC} = read cycle time
 2. These characteristics are guaranteed only for L-version, $V_{IL} = -0.3 \text{ V}$ min, $20 \mu\text{A}$ max. at $T_a = 0$ to 40°C .
 3. These characteristics are guaranteed only for L-SL version, $V_{IL} = -0.3 \text{ V}$ min, $3 \mu\text{A}$ max. at $T_a = 0$ to 40°C .

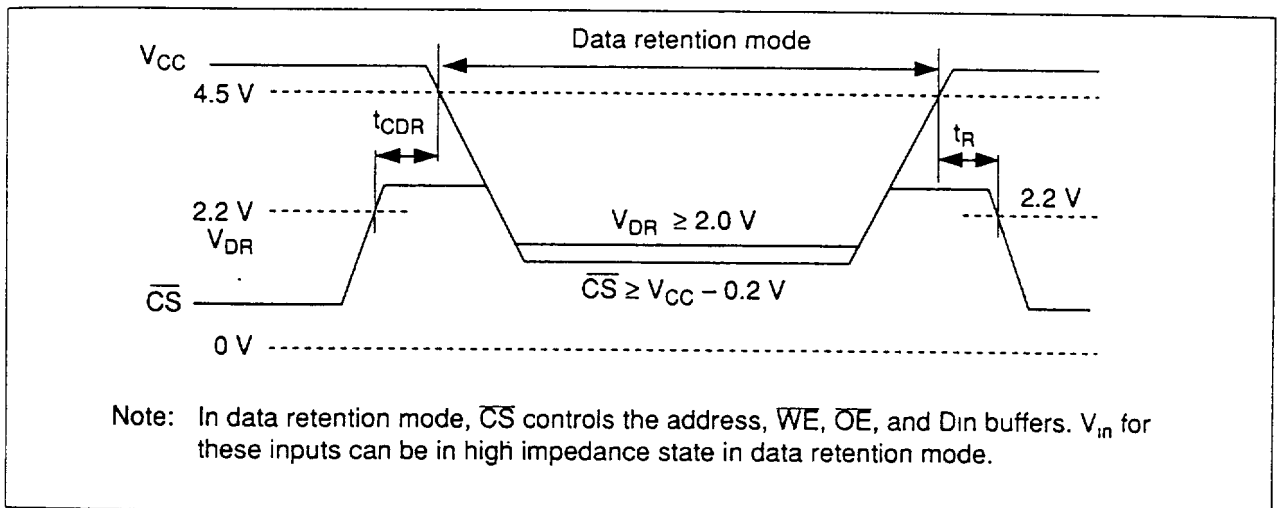
Low V_{CC} Data Retention Waveform

Characteristic Curves

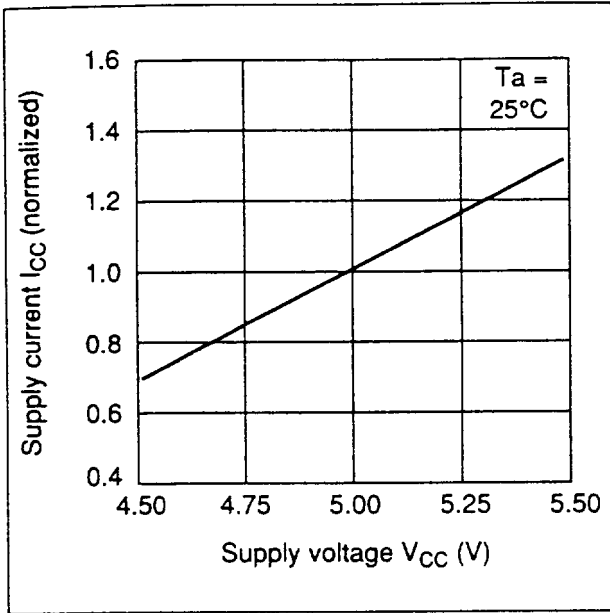

Supply Current vs. Supply Voltage (1)

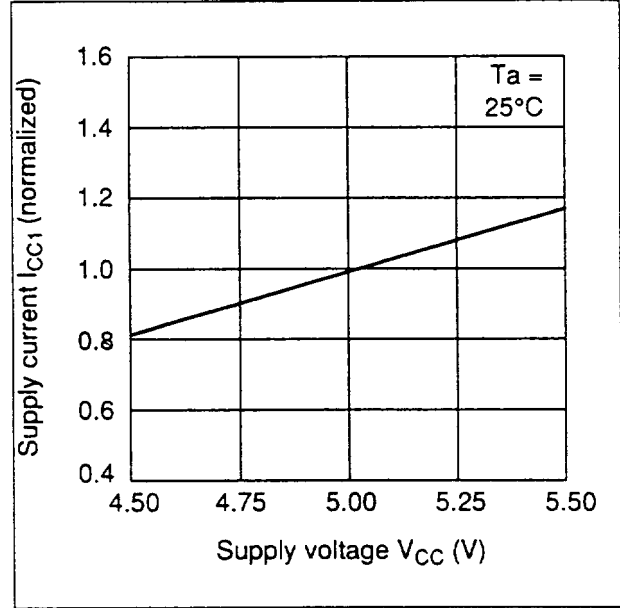

Supply Current vs. Supply Voltage (2)

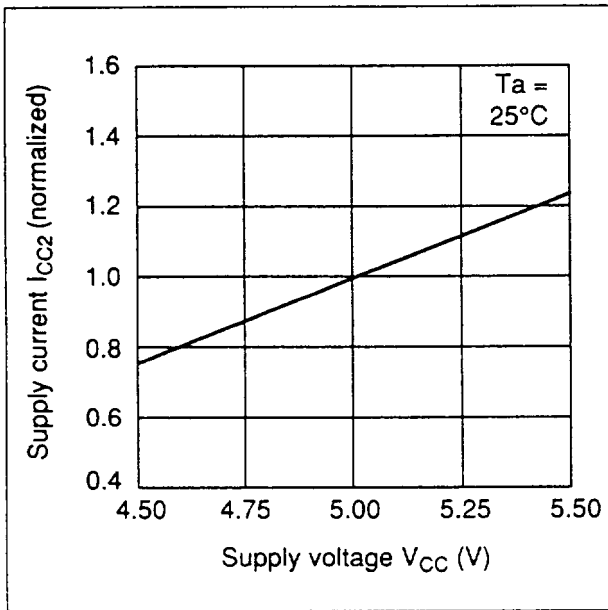

Supply Current vs. Supply Voltage (3)

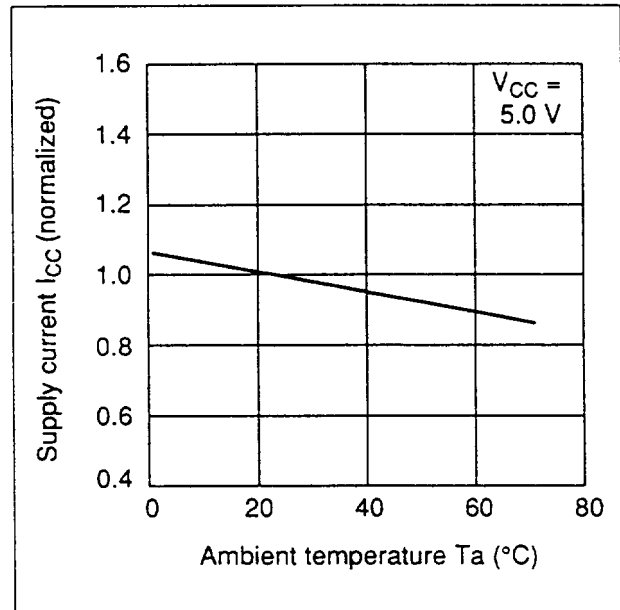

Supply Current vs. Ambient Temperature (1)

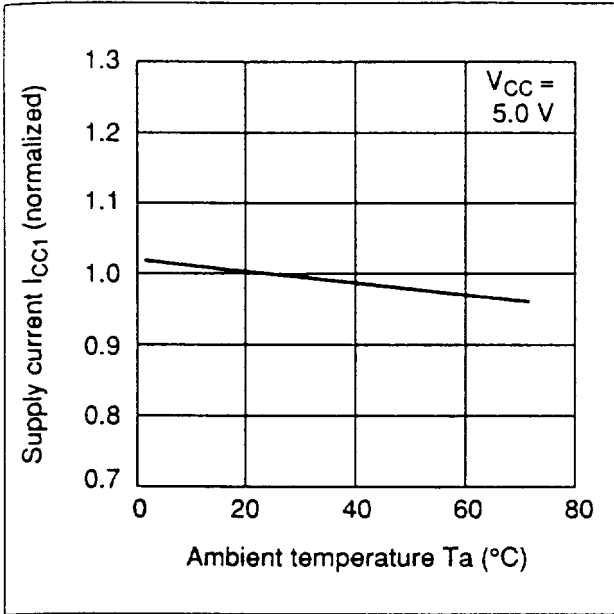

Supply Current vs. Ambient Temperature (2)

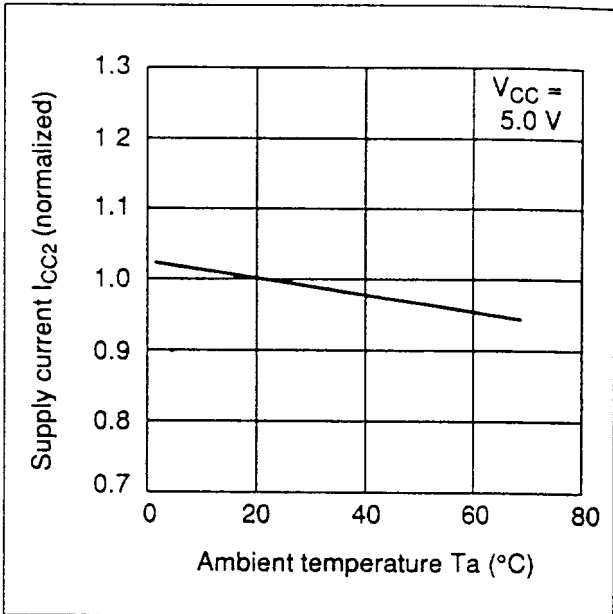

Supply Current vs. Ambient Temperature (3)

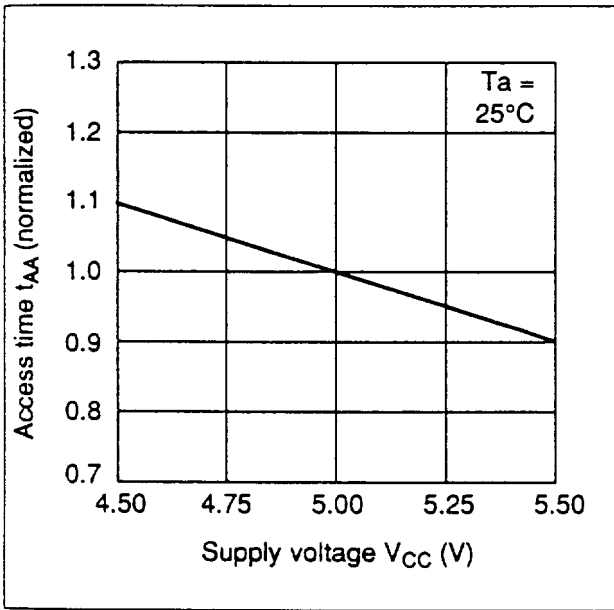

Access Time vs. Supply Voltage

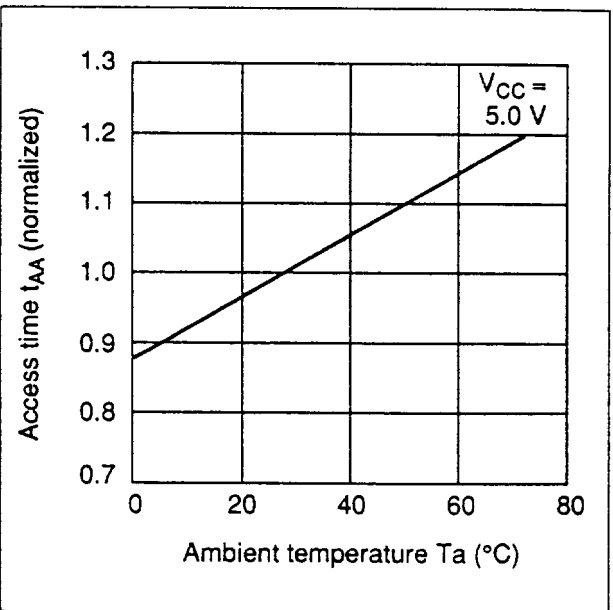

Access Time vs. Ambient Temperature

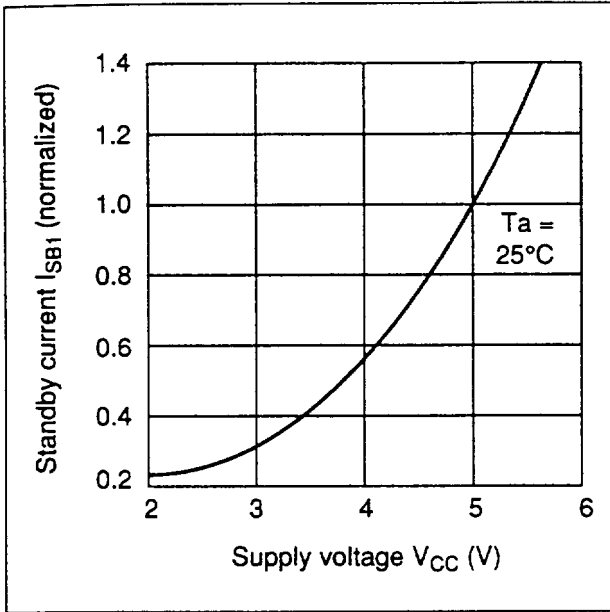

Standby Current vs. Supply Voltage

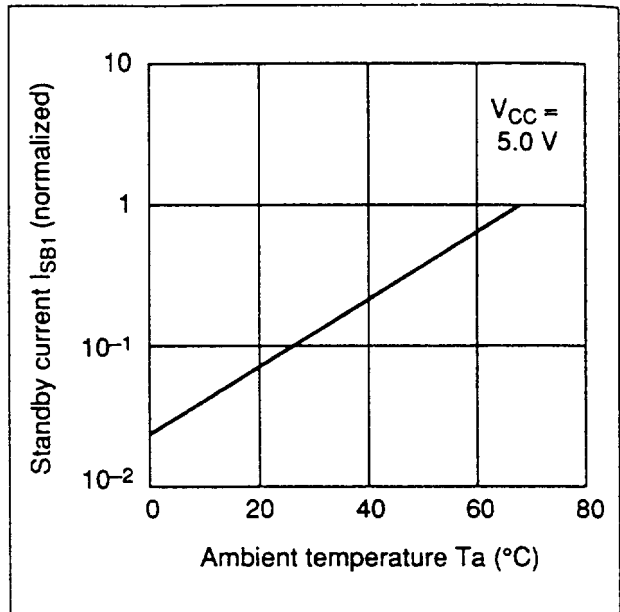

Standby Current vs. Ambient Temperature

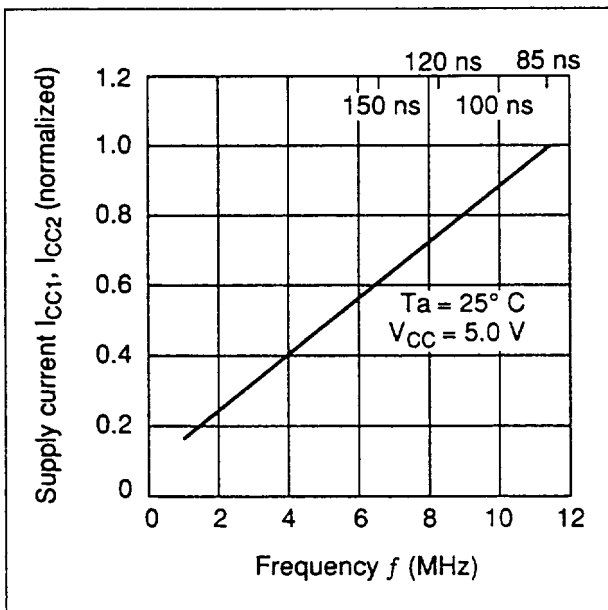

Supply Current vs. Frequency (Read)

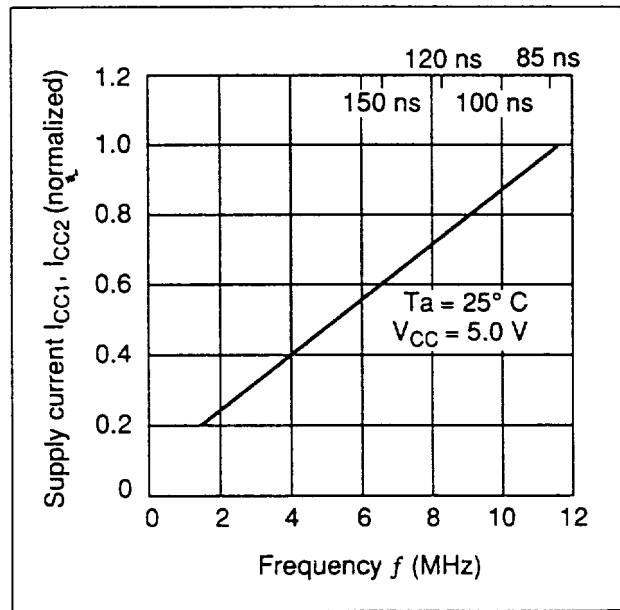

Supply Current vs. Frequency (Write)

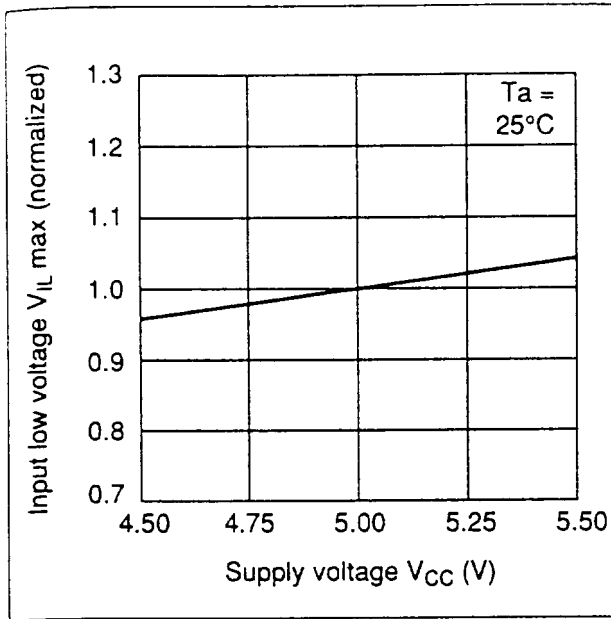

Input Low Voltage vs. Supply Voltage

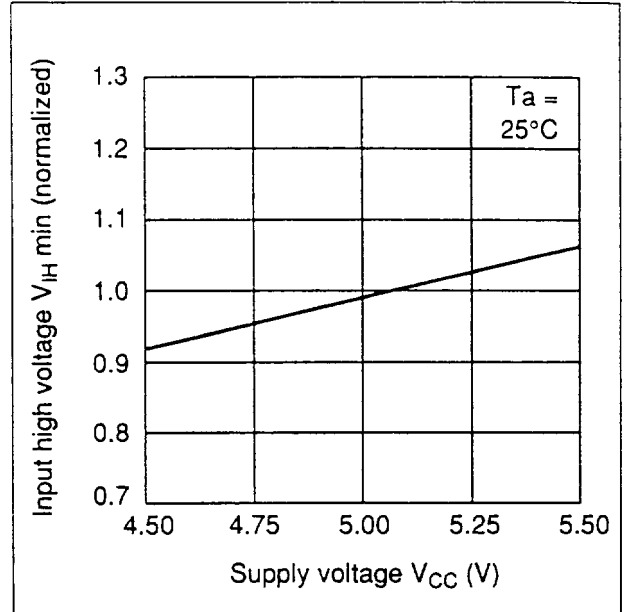

Input High Voltage vs. Supply Voltage

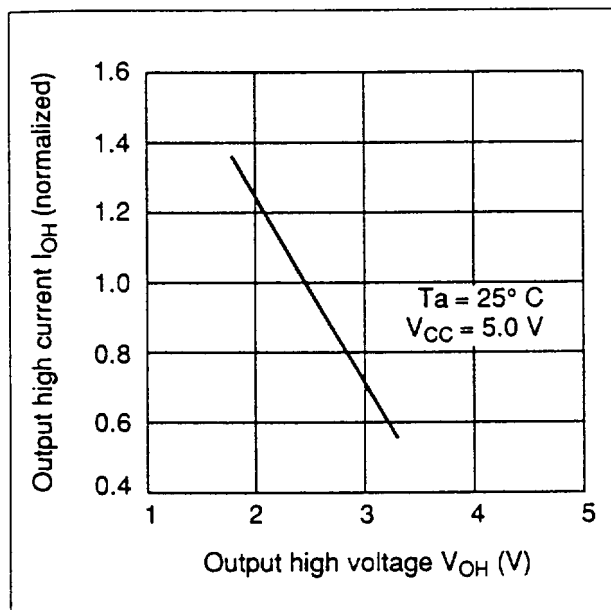

Output Current vs. Output Voltage (High)

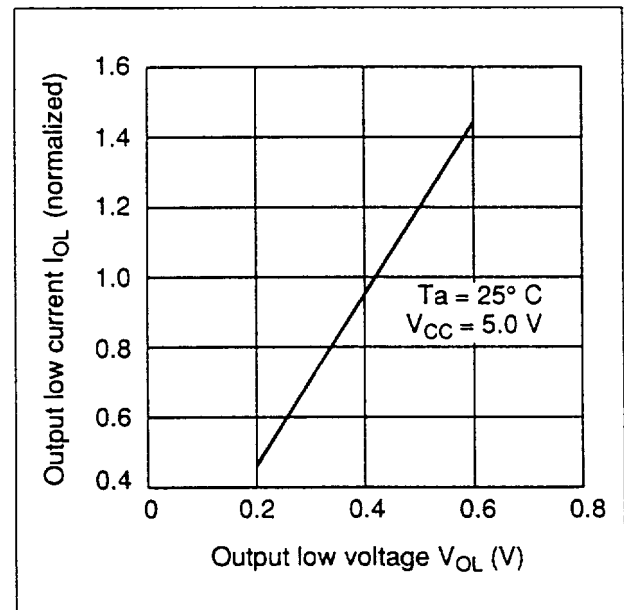

Output Current vs. Output Voltage (Low)

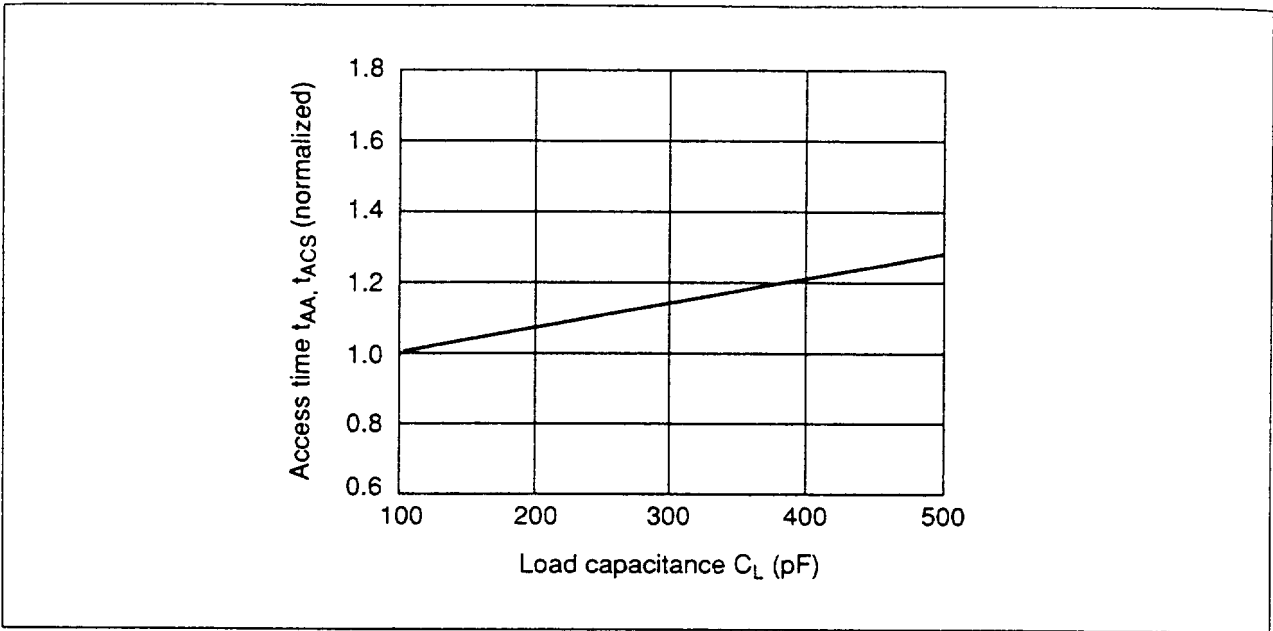

Access Time vs. Load Capacitance